

Eagle Quantum Premier® (EQP) Controller EQ300X

DESCRIPTION

The Eagle Quantum Premier® Controller is a microprocessor based module that performs all the communication and control functions for the fire and gas system. The controller is approved as an annunciation and releasing device for fire alarm systems.

The Local Operating Network/Signaling Line Circuit (LON/SLC), through which all field devices communicate, starts and ends its loop at the Controller. The Controller continuously monitors the field devices on the LON/SLC and performs the logic functions needed to generate the appropriate output(s).

The Controller performs both static and user programmable logic operations. Static logic activates built-in annunciation circuits, consisting of both visible and audible alarms, per ANSI NFPA 72.

Programmable logic allows the Controller to be customized to perform a variety of complex logic operations. Using Det-Tronics Safety System Software (S³), the Controller can be programmed to implement any cross-zone monitoring, voting, or timed operations that might be needed in a fire suppression system.

FEATURES

- Approved annunciation and releasing device per NFPA 72
- Meets FM/CSA guidelines as an approved gas system
- SIL 2 capable model available
- Redundant controller capability
- Programmable logic
- Utilizes MODBUS and Allen Bradley ControlNet protocols
- Four-line, 20 character alphanumeric display
- LED status indicators
- Fault tolerant communication loop
- Extensive built-in diagnostics
- Supports up to 246 field devices
- FM/CSA/ATEX/CE/IECEX
- Model available with US Coast Guard type approval under 46 CFR 161.002



REDUNDANCY

Two EQP controllers can be configured as a redundant pair, thereby increasing the availability of the system. The controllers work in “Master” and “Hot Standby” mode. Under normal operating conditions, the Standby controller receives the same inputs and update information as the Master, but has no control over the outputs and does not execute user logic. In the event of a switchover, a bumpless transfer occurs. Controller redundancy offers the following features:

- Automatic configuration of the standby controller
- Bumpless transfer
- Forced and automatic switchover
- No downtime on controller replacement
- Automatic synchronization between controllers
- Increased system availability.

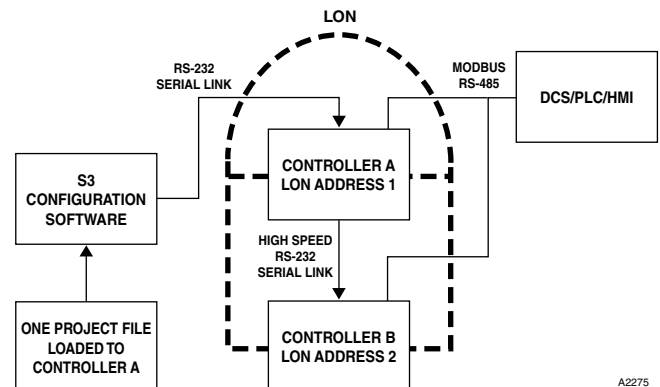

Figure 1—Block Diagram of EQP System with Redundant Controllers

SPECIFICATIONS

Input Voltage 24 Vdc nominal, 18 to 30 Vdc. 10% overvoltage will not cause damage to the equipment.

Input Power 9 watts nominal, 12 watts maximum.

I/O Ports The Controller provides two electrically isolated serial ports, which can be active simultaneously. Port 1 is a RS-232 port used for system configuration. Port 2 is a RS-485 port that supports MODBUS RTU protocol.

An optional dual media ControlNet board is available. This provides a ControlNet interface, which enables users to monitor status information as well as configure various controller parameters.

Serial Interface Board (Optional)
An optional serial board supports up to three additional serial ports. For a redundant controller configuration, the board is required in both controllers.

Unsupervised Outputs (8 Relays)
Dry Contact Rating: 1 ampere at 30 Vdc maximum. SPDT normally open/normally closed contact, configurable for normally energized or de-energized (de-energized is the default mode).

Trouble Output SPDT normally open/normally closed contact. Non-configurable, normally energized only.

Relay Response Time Output relays actuate in <0.1 second after acknowledging an alarm command message.

Unsupervised Digital Inputs (8 Channels)
Two state input (on/off). User selectable normally open or normally closed contact (N.O. is the default).

Temperature Range
Operating (ordinary locations, Det-Tronics verified) -40°C to +85°C (-40°F to +185°F).
Operating (Certified rating) Refer to Certification section in EQP manual (95-8533).
Storage -40°C to +85°C (-40°F to +185°F). Excluding communication port optional modules.

Humidity Range 5 to 95% RH, non-condensing.

Mounting DIN rail or panel mount specified at the time of order.

Vibration FM 3260, FM 6310/6320

CERTIFICATION

FM / CSA: Class I, Div. 2, Groups A, B, C, D (T4).
Class I, Zone 2, Group IIC (T4).
Tamb = -40°C to + 80°C
Performance verified.



ATEX/CE: ATEX/EMC Directive Compliant
Ex II 3 G.
Ex nC IIC T4 Gc.
EN 60079-29-1 & EN 60079-29-4.
DEMKO 02 ATEX 133867X.
Tamb* = -40°C to +80°C.
Tamb = -40°C to +70°C.



IECEX: IECEX ULD 10.0004U.
Ex nC IIC Gc.
Tamb* = -40°C to +80°C.
Tamb = -40°C to +70°C.



*Applicable only if relays 1-7 (terminals 21-41) are configured such that the relay contacts are normally open and de-energized.

SIL: IEC 61508 Certified SIL 2 Capable
Applied to specific models
Refer to the EQP Safety manual (95-8599).



Shipping Weight (Approximate)
5.0 lbs. (2.3 kg).

Dimensions See Figure 2.

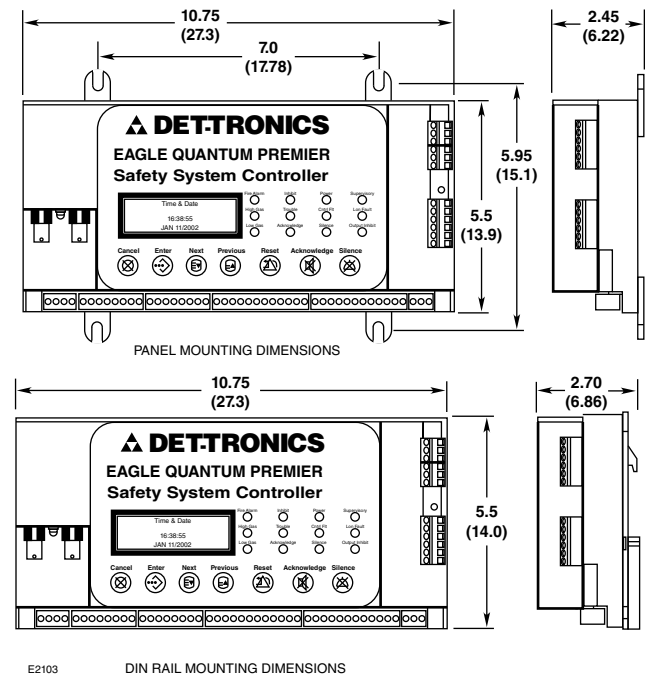

Figure 2—Dimensions of Controller in Inches (Centimeters)

Specifications subject to change without notice.

Det-Tronics and Eagle Quantum Premier are registered trademarks or trademarks of Detector Electronics Corporation in the United States, other countries, or both. Other company, product, or service names may be trademarks or service marks of others.

©Copyright Detector Electronics Corporation 2013. All rights reserved.



Detector Electronics Corporation

6901 West 110th Street • Minneapolis, Minnesota 55438 USA

Operator: (952) 941-5665 or (800) 765-FIRE

Customer Service: (952) 946-6491 • Fax (952) 829-8750

http://www.det-tronics.com • E-mail: det-tronics@det-tronics.com