

FlexVu® Explosion-Proof Universal Display Unit Model UD20



DESCRIPTION

The FlexVu® Model UD20 Universal Display Unit is designed to be used with the GT3000 Toxic Gas Detector, and the Infrared Hydrocarbon Gas Detector PointWatch Eclipse® Model PIRECL.

It is recommended for applications where a 2-wire loop powered gas detector is required. The output is a 4-20 mA signal with HART, corresponding to the output of the GT3000 and PIRECL detectors.

Gas concentrations are displayed on an alpha-numeric display in ppm, % or % LFL. The display unit reads the linear 4-20 mA DC output signal from the GT3000 or the PIRECL that corresponds to the detected gas concentration. The UD20 automatically detects the gas type and operating range of the sensor to which it is connected via the HART signal.

All electronics are enclosed in an explosion-proof aluminum or stainless steel housing. The display unit is used with a single GT3000, which may be either directly coupled to the display unit, or remotely located using a sensor termination box. The display can also be used with a single PIRECL. The UD20 features non-intrusive calibration, which can be performed by using a handheld magnet to activate internal magnetic switches on the faceplate. Calibration can also be performed by activating the GT3000's or the PIRECL's internal magnetic reed switch with a magnet.

The UD20 provides display and control capabilities for the GT3000 or PIRECL, and utilizes the following I/O:

Signal Inputs: 4-20 mA loop from the GT3000 or the PIRECL

User Inputs: Magnetic switches (4) on the display panel

Visible Outputs: LCD display

Signal Outputs: 4-20 mA

FEATURES AND BENEFITS

- Communicates with the GT3000 Detector or the PIRECL detector and allows easy access to important information such as:
 - Sensor fault/status
 - Transmitter fault/status
 - Gas type, range and measurement units
 - History, event, and calibration logs.
- Rugged construction approved for use in classified hazardous areas.
- Performance approved to FM, CSA, ATEX, and IEC standards.
- Local 160 x 100 alpha-numeric LCD display continuously displays the gas level, gas type, and units measured.
- Internal magnetic switches provide a non-intrusive user interface.
- Non-intrusive calibration quickly performed by one person using a hand-held magnetic tool.
- Linear 4 to 20 mA output.
- 2-wire loop powered.

SPECIFICATIONS

Operating Voltage	24 Vdc nominal, operating range is 19 to 30 Vdc. UD20 maximum loop voltage drop (Vd) 5.0 volts. Maximum loop supply 30.0 Vdc.
Operating Power	0.8 watt maximum.
Operating Current	A minimum of 3.5 mA.
Current Output	Linear 4-20 mA with HART output directly from GT3000. 250 ohm termination resistor required (included).
Operating Temperature	-20°C to +70°C.
Storage Temperature	-40°C to +70°C.
Humidity Range	5 to 95% RH (Det-Tronics verified).
Wiring Terminals	22 to 14 AWG wire can be used.
Conduit Entries	3/4" NPT or M25 (Five conduit entries standard).
Enclosure Material	Epoxy coated aluminum or stainless steel (316/CF8M Cast)
Shipping Weight	Aluminum: 4.15 lbs. (1.88 kg). Stainless Steel: 10.5 lbs. (4.76 kg).
Sensor Compatibility	The UD20 can be used with the GT3000 Toxic Gas Detector or the PIRECL combustible gas detector.
Warranty	12 months from date of installation or 18 months from date of shipment, whichever occurs first.
Dimensions	Dimensions shown in inches (centimeters).

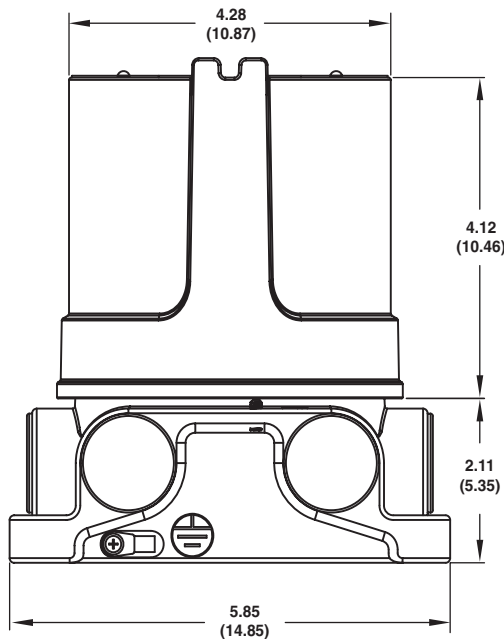

Certification



FM: Class I, Div. 1, Groups B, C & D;
Class I, Div. 2, Groups B, C & D (T4);
Class I, Zone 1/2 AEx d IIC T6;
Class II/III, Div. 1/2, Groups E, F & G.
T_{amb} -20°C to +70°C
NEMA/Type 4X, IP66
Conduit seal not required.

Performance verified in accordance with:
ANSI/ISA-92.0.01
ANSI/ISA-92.02.01
FM 6341 (Draft)
ANSI/ISA-12.13.01
ANSI/ISA-12.13.04/FM 6325
FM 6310/6320

CSA: CSA 08 2162793.
Class I, Div. 1, Groups B, C & D;
Class I, Div. 2, Groups B, C & D (T4);
Class II/III, Div. 1/2, Groups E, F & G.
(T_{amb} = -20°C to +70°C)
Type 4X, IP66
Conduit seal not required.

ATEX: CE 0539 Ex II 2 G
Ex d IIC T6
T_{amb} -20°C to +70°C
FM08ATEX0044X
IP66
Performance verified in accordance with:
EN 60079-29-1/-4 and EN 50241-1/-2.

IECEX: Ex d IIC T6 Gb
T_{amb} -20°C to +70°C
IECEX FMG 08.0010X
IP66
Performance verified in accordance with:
EN 60079-29-1/-4.

INMETRO: CEPEL 12.2128
Ex d IIC T6 Gb IP66
T6 (T_{amb} -20°C to +70°C)

SIL: IEC 61508 certified SIL 2 capable when used with the PIRECL and GT3000-H2S and O2 gas detectors.

Refer to Instruction Manual 95-8620 for in-depth information regarding the FlexVu UD20 Universal Display Unit.

Specifications subject to change without notice.

All trademarks are the property of their respective owners.
© 2016 Detector Electronics Corporation. All rights reserved.



Corporate Office
6901 West 110th Street | Minneapolis, MN 55438 USA
Main: 952.941.5665 or 800.468.3244
Customer Service: 952.946.6491 or 800.765.3473
www.det-tronics.com | Email: det-tronics@det-tronics.com