

**Universal Air Shield Assembly**
**Q1116**
**APPLICATION**

The Q1116 Air Shield Assembly is designed for use with Det-Tronics X3301, X3302, X2200, X5200 and X9800 flame detectors in applications where high levels of airborne contaminants are present in the environment. By providing a constant flow of clean air across the outside surface of the detector viewing window, the Q1116 Air Shield can reduce contamination buildup on the window and extend maintenance intervals.

**DESCRIPTION**

The Q1116 Air Shield Assembly consists of a lightweight aluminum housing, a sintered metal filter ring, and an air inlet, which can be connected to a source of instrument quality compressed air. The mounting arrangement of the air shield allows it to be easily attached to the detector. It is also easily removed when performing detector maintenance. The use of the air shield does not influence detector mounting. See Figure 1 for dimensions.

Connection to the air supply is made using a quick connect coupling. The coupling swivels 360 degrees to facilitate installation in nearly any application.

The Q1116 Air Shield is rated for 0°F to +150°F (-18°C to +66°C). However, if the air inlet fitting is replaced in the field with a standard elbow fitting, the temperature range can be expanded to -40°F to +257°F (-40°C to +126°C).

The air shield normally requires no periodic maintenance. When an accumulation of contaminants causes a reduction in the effectiveness of the air shield, it should be cleaned (if possible) or replaced.

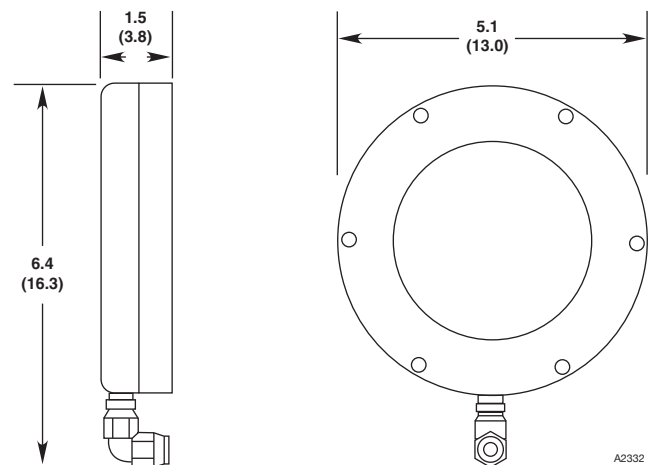

Figure 1—Dimensions of Q1116 in Inches (Centimeters)

## OPERATION

Air enters the Q1116 through the air inlet and exits through the sintered metal ring (Figure 2). This continuous flow of clean air forms an air buffer around the detector viewing window, reducing the accumulation of contaminants.

The air shield does not entirely eliminate contamination on the optical surfaces of the detector and the **oi** ring. Rather, it enables the detector to be used effectively in applications that otherwise would be difficult or impossible to monitor, and extends the time interval between cleanings.

## AIR SUPPLY

Connection to the compressed air supply is provided using a quick connect coupling. The recommended tubing is 1/4 inch O.D. parflex nylon with a minimum wall thickness of 0.035 inch. The air pressure supplied to the air inlet should be 12 to 20 psi with 3 or more cubic feet per minute available.

### NOTE

*The length of the tubing run affects the diameter of tubing required to deliver the proper air flow at the detector. Increase tubing diameter as needed to ensure adequate air flow.*

### NOTE

*Instrument grade air is required. A dedicated regulator for each unit is also required. Filtration should be used to ensure that the air is dry and oil free. The presence of oil in the air supply must be avoided, since it can accumulate on the detector viewing window and reduce the sensitivity of the detector. In addition, oil can clog the sintered metal ring and reduce the effectiveness of the air shield.*

## CONE OF VISION

The detector cone of vision is virtually unchanged when using the Q1116 Air Shield Assembly.

## OPTICAL INTEGRITY

The air shield does not in any way interfere with either manual or automatic testing of the detector by the **oi** feature. Refer to the system instruction manual for information regarding **oi** operation.

## INSTALLATION PROCEDURE

1. Prior to installing the air shield, clean the detector viewing windows and **oi** plate using the procedure described in the "Maintenance" section.
2. Place the air shield on the front of the detector. See Figure 2.
3. Tighten the three retaining screws to hold the assembly securely in place.

### NOTE

*In applications where static electricity buildup is a concern (such as powder coating booths), electrically connect the ground lug on the air shield (Figure 2) to the ground lug on the detector housing.*

4. Attach the air supply to the air shield.
5. Apply power to the detection system and turn on the air supply.

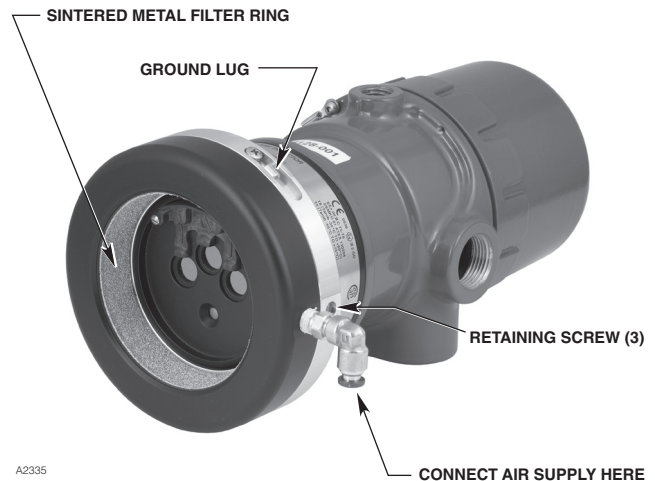

Figure 2—Q1116 Air Shield Attached to X3301 Detector

## MAINTENANCE

### AIR SHIELD

No routine maintenance is required. However, as contaminants accumulate on the sintered metal diffuser ring over time, the effectiveness of the air shield will be reduced.

When an accumulation of contaminants causes a reduction in the effectiveness of the air shield, it should be cleaned (if possible) or replaced. To replace the ring, remove the gasket and unscrew the retainer from the inside of the air shield. Replace the diffuser ring and reassemble the air shield.

### RECOMMENDED CLEANING PROCEDURE FOR DETECTOR WINDOWS AND **oi** PLATE

If the detector indicates an **oi** fault, the detector windows and **oi** plate must be cleaned. The following procedure is recommended for cleaning the detector viewing windows and **oi** plate:

1. Secure output loads (or place the controller/panel in the TEST or BYPASS mode).
2. Remove the air shield assembly from the detector.
3. Remove the **oi** plate from the detector.
4. Thoroughly clean the detector viewing windows with a clean cloth and Det-Tronics window cleaner.

#### NOTE

*If paint overspray or similar contaminants are present in the environment, the use of solvents may be required to clean the detector viewing windows. After cleaning the viewing windows with a solvent, always use Det-Tronics window cleaner and a clean cloth to remove any solvent or other residue.*

5. Clean the **oi** plate. If the reflective surfaces cannot be restored, the plate must be replaced. It is essential for the plate to be highly reflective to ensure proper operation of the **oi** system.
6. Re-install the **oi** plate.
7. Re-install the air shield.
8. Return the system to normal operation.

## ORDERING INFORMATION

When ordering, please specify:

Part Number	Description
007240-001	Q1116 Universal Air Shield Assembly
001680-001	Window cleaner

For assistance in ordering a system to meet the needs of a specific application, please contact:

Detector Electronics Corporation  
6901 West 110th Street  
Minneapolis, Minnesota 55438 USA  
Operator: (952) 941-5665 or (800) 765-FIRE  
Customer Service: (952) 946-6491  
Fax: (952) 829-8750  
Web site: [www.det-tronics.com](http://www.det-tronics.com)  
E-mail: [detronics@detronics.com](mailto:detronics@detronics.com)

**Detector Electronics Corporation**

6901 West 110th Street • Minneapolis, Minnesota 55438 • Operator (952) 941-5665 or (800) 765-FIRE  
Customer Service (952) 946-6491 • Fax (952) 829-8750 • [www.det-tronics.com](http://www.det-tronics.com) • E-mail: [detronics@detronics.com](mailto:detronics@detronics.com)