

FlexVu® Universal Display Model UD10 Model UD10 with CGS

SAFETY CERTIFIED MODEL UD10 UNIVERSAL DISPLAY

This manual addresses the specific requirements and recommendations applicable to the proper installation, operation, and maintenance of all Safety-Certified (SIL-Certified) FlexVu® Model UD10 Universal Display product versions (“UD10” refers to both UD10 and UD10 with CGS). For complete information regarding system overview, performance, installation, operation, maintenance and specifications of the Model UD10 refer to instruction manual 95-8661.

QUALITY POLICY STATEMENT

All quality assurance control measures necessary for safety management as specified in IEC 61508 Part 1 have been implemented. The quality management system of Det-Tronics is based on the requirements of EN ISO 9001 and ANSI/ASQC Q9001 through the application of the United Technologies Company Achieving Competitive Excellence (ACE) program. In addition, the Quality Management System complies with the European ATEX Directive requirements per EN 13980, the International Electrotechnical Commission requirements per OD005/V2, and the supervised testing requirements per ISO 17025.

SAFETY MESSAGES

Procedures and instructions in this section may require special precautions to ensure the safety of personnel performing the operations. Information that raises potential safety issues is indicated by the word “Warning”. Always read and understand these safety messages.



WARNING

The Model UD10 Universal Display is intended for use in hazardous environments that may include explosive levels of flammable gases and vapors. This product must be properly installed, operated and maintained. Improper installation or use could result in an explosion or fire resulting in death or serious injury.

- *Do not remove the cover in explosive environments when device power is on and circuits are live.*
- *Device must be properly installed, and cover must be fully engaged to meet hazardous area explosion-proof/non-incendive requirements.*

DESIGN

The Model UD10 Universal Display is a stand alone device that performs all the functions of a gas controller and is classified as Type B smart device according to IEC61508. It provides an isolated 4-wire 4-20 mA output that is representative of the received input 4-20 mA level. The UD10 contains extensive self-diagnostics and is programmed to send the current output to a specified failure state upon internal detection of a failure (see UD10 instruction manual for details). Alarm and Fault relay contact outputs are provided in addition to the analog signal output, and can be programmed in the field by the user. The relay output and analog output are not to be used in combination for the safety function.

Safety-Certification of the UD10 Universal Display includes:

- the 4-20 mA input and output
- the High Alarm, Auxiliary, and Fault relay outputs

Safety Certification of the UD10 Universal Display includes the following non-interfering outputs:

- UD10 display and magnetic switches
- HART communication
- Modbus communication
- Foundation Fieldbus communication.

The HART communication protocol is non-interfering and is to be used for diagnostics within the SIL 2 safety loop in the Safety operation mode. Diagnostics are defined as read only information. Local HART communication with the UD10 Universal Display using a handheld HART field communicator, or AMS program connected to the 4-20 mA output, is acceptable. Proper analog signal loop resistance must be installed as documented in the instruction manual to enable local HART communication.

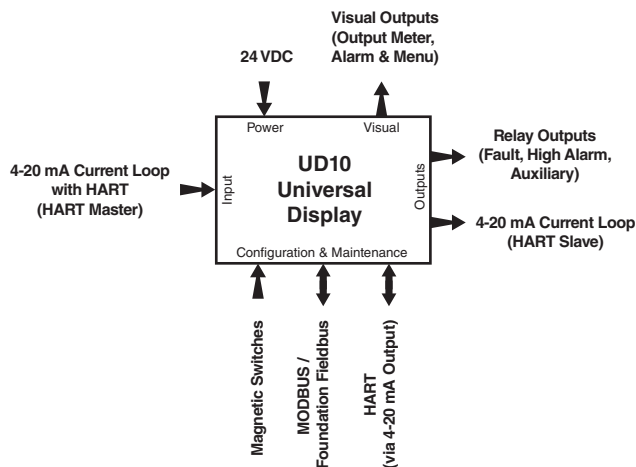

VALID INPUT RANGE

UD10 fault annunciation is provided on the 4-20 mA signal output loop by signaling to a specific mA current output level. The receiving device must be programmed to indicate a fault condition when current levels reach undercurrent of 3.6 mA or less or overcurrent of 21 mA or more.

NOTE

The UD10 analog signal and relay outputs are not safety-rated during detector warm-up, calibration mode, or during signal output loop testing. Alternative means should be used at the job site to ensure facility safety during these activities.

DIAGNOSTIC RESPONSE TIME

The UD10 Universal Display will perform all critical diagnostic functions within 58 minutes, worst case diagnostic detection time.

CERTIFICATION

The UD10 Safety-Certified version is certified by *exida*[®] to IEC61508 for single input use in low demand, SIL 2 Safety Instrumented Systems.

SAFETY-CERTIFIED PRODUCT IDENTIFICATION

Safety Certification of all UD10 models meeting SIL 2 safety standards is clearly identified on the product label.

INSTALLATION

NOTE

For complete information regarding performance, installation, operation, maintenance and specifications of Model UD10, refer to instruction manual 95-8661.

No special or additional detector installation requirements exist above and beyond the standard installation practices documented in the Model UD10 instruction manual.

The operating temperature range for the Safety Certified UD10 is -55°C to $+75^{\circ}\text{C}$ for the analog output and -45°C to $+75^{\circ}\text{C}$ for the relay outputs. Other environmental operating specifications are applicable as published in the general specifications section in the Model UD10 instruction manual.

The UD10 operating power distribution system should be designed and installed so the terminal voltage does not drop below 18 Vdc when measured at any specific location. The maximum current limit per device must be less than 2 amperes. The external system providing power to the UD10 must have over-voltage protection that ensures supply voltage does not exceed 30 Vdc.

COMMON MISUSE SCENARIOS

Refer to the Installation and Troubleshooting sections of the instruction manual for detailed information on avoidance and resolution of common misuse scenarios. Applications to avoid include the following:

- Locations where impact or other excessive mechanical stress is likely.
- Locations where the UD10 display is not easily viewable or accessible.
- Mounting the UD10 without properly sealing ALL conduit entries.

START-UP AND COMMISSIONING

NOTE

All safety functions of the UD10 are active within 150 seconds of power-up without any user action required.

Commissioning Personnel

The Safety Certified UD10 Universal Display can be commissioned by any qualified person with knowledge of the detection instruments and configuration devices being used. Refer to the Start-Up and Calibration sections provided in the UD10 instruction manual.

Configuration

The UD10 faceplate display or a HART handheld device can be used to monitor internal status or to modify the factory settings. Refer to the UD10 instruction manual for guidance on using the UD10 LCD display, HART, MODBUS, or Foundation Fieldbus communication. Specifics on HART or UD10 display communication can be found in the appropriate Appendix of the instruction manual. The proper Appendix is determined by the sensor being used with the UD10.

NOTE

Prior to device configuration (setting alarm thresholds, latch/non-latch function, etc.) all alarm outputs must be bypassed. The device is not safety certified during configuration change activities.

NOTE

All configuration changes to the UD10 must be verified by the user via a proof test, power cycle and re-check of settings, or other appropriate method.

Relay Configuration Requirements

Only the UD10's Alarm and Fault relay outputs may be used as part of a Safety Certified system. The

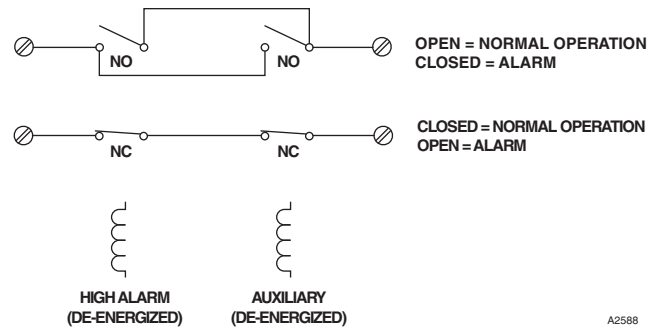

Figure 1—High Alarm and Auxiliary Relays Configured as a De-Energized Pair

High Alarm and Auxiliary relays must be configured identically to operate as a pair. The end user must monitor the High Alarm and Auxiliary relays as a pair using either the NO contacts wired in parallel or the NC contacts wired in series. See Figure 1. The end user must provide transient protection and current limiting on the output contacts of the relays. The maximum relay contact output must be limited to 2 amperes at 30 Vdc. The load must be a resistive load. The user must protect against transients by using standard protection methods such as proper grounding of shielded wire and separation of relay load wires from other lines carrying rapidly switched high current (e.g. large motor power supply lines).

If the 0-20 mA analog output of the UD10 is not being monitored for fault conditions, the status of the Fault relay must be monitored and appropriate action taken if a fault signal is received.

4-20 mA Configuration Requirements

The UD10 must be configured to use the 4-20 mA output loop diagnostic. This diagnostic ensures that the 4-20 mA output is being driven to the correct level.

To enable this function, navigate the HART menu as follows:

Main Menu > Display Setup > OP Feedback Ft.
Select ON.

After enabling the output loop diagnostic function, perform an output loop calibration. Refer to the “UD10 Output Trim” section in the UD10 Instruction Manual (number 95-8661) for detailed instructions.

NOTE

The actual 4-20 mA output can be read on the UD10 display by navigating to: Display Status > Debug Menu > Output Readback. "Output Readback" is the actual 4-20 mA output as read by the UD10.

Configuration Protection

Upon completion of installation and commissioning, it is required that the user password-protect the UD10 safety related parameters that are accessible via the faceplate display, HART, MODBUS, or Foundation Fieldbus in order to prevent accidental or deliberate change of configuration data during normal operation. To password protect the UD10, the user must set the write-protect function to "on" and enter an 8 character password.

The user will be required to disable write protect prior to any future configuration changes, and must re-enable write protect upon completion of these changes.

OPERATION, MAINTENANCE, INSPECTION AND PROOF TESTING

All normal installation, start-up, and field calibration recommendations as documented in the UD10 instruction manual are applicable to the Safety Certified UD10 Universal Display.

Safety-Certified UD10 Universal Displays require additional Proof testing to be performed in all cases.

Personnel performing Proof Test procedures shall be competent to perform the task. All proof test results must be recorded and analyzed. Any corrective actions taken must be documented in the event that an error is found in the safety functionality. The Proof tests must be performed at a frequency as shown in Table 1.

WARNING

Failure to perform the specified testing and inspection may lower or void the SIL rating for the product or system.

VISUAL FIELD INSPECTION PROOF TEST

Tools Required: None

Visual inspection of Safety-Certified UD10 and connected devices shall be conducted as needed to confirm that no external blockage of path into the sensing chamber/area exists, eg. debris, trash, snow, mud, external equipment, etc. Corrective action shall include removal of such impediments should they exist. All devices monitored by the UD10 must be inspected to ensure that they are capable of providing expected performance and protection.

Completion of Visual Field Inspection Proof test must be recorded and documented in the SIS logbook.

RESPONSE PROOF TEST

Tools Required: Compressed Calibration Gas Kit provided by Det-Tronics, or other device stimulation method

The Response Proof Test must be performed while the UD10 and attached device are in NORMAL operation and requires application of sufficient stimulation to put the device into alarm state. The user must then inspect the signal output level to ensure that the signal output is accurately indicative of the applied condition.

WARNING

Any external alarm equipment, systems or signaling devices that could be automatically initiated by performing this test must be disabled or bypassed before performing this test!

Table 1—Frequency for Performing Proof Tests

UD10 Proof Test Name	Commissioning	Frequency
Visual Field Inspection Proof Test	Yes	As needed, depending on level and type of contaminants present
Response Proof Test	Yes	10 years

Response Proof Test Sequence

1. Inhibit alarm and fault response at the control device.
2. Apply stimulation to the attached device that is sufficient to trip both the auxiliary and high alarm relays (the auxiliary and high alarm relays must be normally configured to trip at the same input 4-20 mA level).
3. Verify correct change of state at the control device for both alarm relay outputs and the 4-20 mA output. Criteria for the 4-20 mA inspection pass of a gas detector is a response signal within $\pm 3\%$ of applied gas concentration (generally, a 50% full scale test concentration is applied).
4. Optional (the display is not part of the UD10 safety function): Verify that the correct signal output is displayed on the UD10 faceplate.
5. Remove the test gas or other stimulation method and ensure that the unit returns to normal operation.
6. Induce a fault to the UD10; suggested fault induction methods are listed below:
 - Remove input power to the UD10.
 - Lower input supply voltage below 16 Vdc.
 - Remove input 4-20 mA source (i.e. remove connected gas sensor or other device).
7. Verify correct change of state to fault relay and 4-20 mA outputs at the control device.
8. Optional (the display is not part of the UD10 safety function): Verify that the correct fault signal output is displayed on the UD10 faceplate.
9. Remove the fault induction source and ensure that the unit returns to normal operation.
10. Re-activate alarm and fault response at the control device.

If response test is not within acceptable limits or fails for any reason, a Full Calibration procedure must be performed and the Proof Test re-performed. The Full Calibration procedure for gas detectors is listed below. For calibration of other devices, refer to the manual for the specific device.

Full Calibration

Tools Required: Compressed Calibration Gas Kit provided by Det-Tronics
Magnet or HART Communicator

Full Calibration shall be conducted when required as documented in the Calibration section of the UD10 instruction manual. It is permissible to conduct the Full Calibration using either the onboard magnetic calibration switch or using an approved HART handheld field communicator. In all cases the model UD10 and attached gas detector should be allowed to warm up for one hour minimum before conducting calibration.

Completion of the Response Proof Test must be recorded and documented in the SIS logbook.

WARNING

Any external alarm equipment, systems or signaling devices that were disabled must be re-activated at the conclusion of proof testing activities.

FAULT/FAILURE ACTION PLAN

In the event of an unsuccessful Response Proof test after a Calibration has been performed, the standard Troubleshooting and Device Repair and Return procedures as listed in the UD10 instruction manual must be followed. Any failure to successfully complete the Response Proof Test must be recorded and documented in the SIS logbook.

PRODUCT REPAIR

The UD10 is not field repairable, and any internal device repairs must be conducted at the factory. No firmware changes are permitted or authorized. All failures detected by the device diagnostics or by the Proof Tests that cannot be resolved through the troubleshooting and maintenance procedures described in the instruction manual must be reported to the manufacturer.

OPERATING, ENVIRONMENTAL, AND PERFORMANCE SPECIFICATIONS

The Safety-Certified UD10 product versions fully comply with, and must be operated in accordance with the functional, environmental, and performance specifications provided in the UD10 instruction manual. A 24 hour mean time to repair should be assumed for safety availability calculations.

SPARE PARTS

Refer to “Replacement Parts” in the UD10 instruction manual. Safety Certification is based on a sufficient number of spares to achieve a 24 hour mean time to repair.

CERTIFICATION AND FAILURE RATE DATA

IEC61508: 2010

Type B Device

Systematic Capability: SIL 2 certified

HFT: 0

Low Demand Mode

PFDavg should be calculated for any safety instrumented function using the UD10. (Refer to FMEDA report for necessary information, including DU rate.)

Safety Accuracy: <4% error (see SPECIFICATIONS section of instruction manual for performance details).

Safety Response Time: The UD10 contributes less than 2 seconds to the worst case safety response time.

Product Life: 10 years, based on manufacturer data.

All failure rate data for SIL verification is in the FMEDA report, which is available upon request.

ADDITIONAL CERTIFICATIONS

FM, CSA, ATEX, IECEx, CE, INMETRO (Brazil), VNIIFTRI (Russia).

Refer to the Model UD10 Instruction Manual for details.

For complete information regarding performance, installation, operation, maintenance and specifications of Model UD10, refer to instruction manual 95-8661.

TERMS AND DEFINITIONS

FMEDA	Failure Mode Effects and Diagnostics Analysis
HART	Highway Addressable Remote Transducer
HFT	Hardware Fault Tolerance
LFL	Lower Flammable Limit
PFD	Probability of Failure on Demand (Probability of Dangerous Failure)
PFDavg	Average Probability of Failure on Demand
SFF	Safe Failure Fraction
SIF	Safety Instrumented Function
SIL	Safety Integrity Level
SIS	Safety Instrumented System
UD10	FlexVu® Model UD10 Universal Display
CGS	Combustible Gas Sensor

IEC 61508 Failure Rates in FIT¹

Failure Category	l _{sd}	l _{su} ²	l _{dd}	l _{du}	SFF ³
UD10 Analog Output	0	69	555	53	92.2%
UD10 Relay Output	0	195	514	50	93.5%
UD10 with CGS Analog Output	0	69	2567	1356	NA
UD10 with CGS Relay Output	378	195	2316	1356	NA

¹ FIT = 1 Failure / 10⁹ Hours

² It is important to realize that the No Effect failures are no longer included in the Safe Undetected failure category according to IEC 61508, ed2, 2010.

³ Safe Failure Fraction needs to be calculated on (sub)system level.

Specifications subject to change without notice.

Det-Tronics, the DET-TRONICS logo, and FlexVu are registered trademarks or trademarks of Detector Electronics Corporation in the United States, other countries, or both. Other company, product, or service names may be trademarks or service marks of others.

©Copyright Detector Electronics Corporation 2017. All rights reserved.



Corporate Office

6901 West 110th Street | Minneapolis, MN 55438 USA

Phone: 952.941.5665 or 800.468.3244

Customer Service: 952.946.6491 or 800.765.3473

www.det-tronics.com | Email: det-tronics@det-tronics.com