

Instructions

FlexVu® Explosion-Proof

Universal Display Unit

Model UD10



Table of Contents

| | | | |
|---|-----|--|-----|
| APPLICATION | 1 | Menu Structure | G-4 |
| DESCRIPTION | 1 | APPENDIX H — UD10 WITH PIR9400 POINTWATCH .. | H-1 |
| HART Communication | 3 | Wiring | H-1 |
| Magnetic Switches | 3 | Installation Notes | H-2 |
| Gas Level Indication | 4 | Orientation | H-2 |
| Special States | 4 | Changing Operating Modes | H-3 |
| Relays | 5 | Calibration | H-3 |
| 4-20 mA Output Modes | 5 | Menu Structure | H-4 |
| Modbus | 5 | APPENDIX I — UD10 WITH MODEL PIRECL | I-1 |
| Device Enclosure | 5 | Wiring | I-1 |
| Device Display | 5 | Orientation | I-2 |
| Logging | 6 | Calibration | I-3 |
| IMPORTANT SAFETY NOTES | 6 | Menu Structure | I-4 |
| INSTALLATION | 7 | APPENDIX J — UD10 WITH OPEN PATH MODEL OPECL ... | J-1 |
| Identification of Vapor(s) to be Detected | 7 | Wiring | J-1 |
| Identification of Detector Mounting Locations | 7 | Orientation | J-3 |
| WIRING | 8 | Calibration | J-3 |
| Power Supply Requirements | 8 | OPECL Transmitter Lamp Fault Condition | J-4 |
| Wiring Cable Requirements | 8 | Menu Structure | J-4 |
| Shield Connections | 8 | APPENDIX K — UD10 WITH NTMOS H2S SENSOR ... | K-1 |
| Jumper Setting for 4-20 mA Loop | 8 | Wiring | K-1 |
| Wiring Procedure | 9 | Installation Notes | K-1 |
| STARTUP | 12 | Orientation | K-4 |
| TROUBLESHOOTING | 16 | Calibration | K-4 |
| SPECIFICATIONS | 19 | Menu Structure | K-5 |
| DEVICE REPAIR AND RETURN | 22 | APPENDIX L — UD10 WITH C706X TOXIC GAS SENSOR . | L-1 |
| ORDERING INFORMATION | 22 | Wiring | L-1 |
| APPENDIX A — FM APPROVAL DESCRIPTION | A-1 | Installation | L-3 |
| APPENDIX B — CSA CERTIFICATION DESCRIPTION . | B-1 | Calibration | L-4 |
| APPENDIX C — ATEX APPROVAL DESCRIPTION | C-1 | Menu Structure | L-4 |
| APPENDIX D — IECEx APPROVAL DESCRIPTION | D-1 | APPENDIX M — UD10 WITH MODEL CGS SENSOR .. | M-1 |
| APPENDIX E — ADDITIONAL APPROVALS | E-1 | Wiring | M-1 |
| APPENDIX F — UD10 WITH HANDHELD HART | | Important Notes | M-1 |
| COMMUNICATOR | F-1 | Installation | M-3 |
| Wiring | F-1 | Calibration | M-3 |
| Menu Structure | F-1 | K-Factor | M-4 |
| APPENDIX G — UD10 WITH GT3000 TOXIC GAS | | Menu Structure | M-4 |
| DETECTOR | G-1 | APPENDIX N — UD10 WITH MODEL 505/CGS | N-1 |
| Wiring | G-1 | Wiring | N-1 |
| Orientation | G-2 | Installation | N-2 |
| Live Maintenance | G-2 | Orientation | N-2 |
| Calibration | G-3 | Calibration | N-3 |
| | | Menu Structure | N-4 |
| | | APPENDIX O — UD10 WITH GENERIC 4-20 MA | |
| | | SENSOR | O-1 |
| | | Operation | O-1 |
| | | Menu Structure | O-1 |

Table of Contents

APPENDIX P— UD10 WITH ATX10/AC100 GAS DETECTOR P-1

| | |
|-------------------------|-----|
| Wiring | P-1 |
| Installation | P-3 |
| Menu Structure. | P-3 |

APPENDIX Q — UD10 WITH MODEL PIRDUCT Q-1

| | |
|------------------------------------|-----|
| Wiring | Q-1 |
| Installation Notes. | Q-2 |
| Orientation | Q-2 |
| Changing Operation Notes | Q-3 |
| Calibration. | Q-4 |
| Menu Structure | Q-4 |

APPENDIX R — UD10 WITH MODEL PIRECL CO₂

| | |
|-------------------------|-----|
| DETECTOR | R-1 |
| Wiring. | R-1 |
| Orientation | R-2 |
| Calibration | R-3 |
| Menu Structure. | R-4 |

APPENDIX S — UD10 WITH LS2000 LINE OF SIGHT GAS

| | |
|-------------------------|-----|
| DETECTOR | S-1 |
| Wiring. | S-1 |
| Installation | S-3 |
| Calibration | S-3 |
| Menu Structure. | S-4 |

**FlexVu® Explosion-Proof
Universal Display Unit
Model UD10****IMPORTANT**

Be sure to read and understand the entire instruction manual before installing or operating the gas detection system. This product can be used with a variety of Det-Tronics gas detectors to provide early warning of the presence of a toxic or explosive gas mixture. Proper device installation, operation, and maintenance is required to ensure safe and effective operation. If this equipment is used in a manner not specified in this manual, safety protection may be impaired.

APPLICATION

The FlexVu® Model UD10 is recommended for applications that require a gas detector with digital readout of detected gas levels as well as analog 4-20 mA output with HART, relay contacts, and Modbus RS485. The UD10 Universal Display Unit is designed for use with Det-Tronics gas detectors listed in Table 1.

The display unit is designed and approved as a “stand alone” device and performs all the functions of a gas controller.

When furnished with the CGS interface board, the device can be used only with a CGS sensor for detection of combustible gas. The UD10/CGS combination is certified as a “Gas Detector.”

Gas concentration and unit of measurement are displayed on a digital display. The display unit provides a linear isolated/non-isolated 4-20 mA DC output signal (with HART) that corresponds to the detected gas concentration.

All electronics are enclosed in an explosion-proof aluminum or stainless steel housing. The display unit is used with a single detector that may be either coupled directly to the UD10, or remotely located using a sensor termination box.

The UD10 features non-intrusive calibration. A magnet is used to perform calibration as well as to navigate the UD10’s internal menu.

**DESCRIPTION**

The UD10 Universal Display can be used with various 4-20 mA gas detection devices, with or without HART. The unit provides display, output, and control capabilities for the gas detector.

The UD10 utilizes the following I/O:

- Signal Inputs: 4-20 mA loop from the sensing device
- User Inputs: Magnetic switches (4) on the display panel
HART communication
- Signal Outputs: 4-20 mA output loop with HART
Modbus RS485
Three alarm relays and one fault relay
- Visible Outputs: Backlit LCD display
HART slave interface via HART Communicator

Table 1—Range and Default Values for Alarms and Calibration Gas Concentration

| UD10 ALARM DATA | | | | | CALIBRATION |
|---------------------------|---------|--------------------|--------------------|--------------------|--------------------|
| Gas Detector | | High Alarm Value | Low Alarm Value | Aux alarm Value | Cal Gas |
| GT3000--Hydrogen Sulfide | Range | 10-90% | 5-50% | 5-90% | 30-90% |
| | Default | 40% | 10% | 40% | 50% |
| GT3000--Ammonia | Range | 10-90% | 5-50% | 5-90% | 30-90% |
| | Default | 40% | 10% | 40% | 50% |
| GT3000--Chlorine | Range | 10-90% | 5-50% | 5-90% | 30-90% |
| | Default | 40% | 10% | 40% | 50% |
| GT3000--Hydrogen | Range | 10-60% | 5-50% | 5-90% | 30-90% |
| | Default | 40% | 10% | 40% | 50% |
| GT3000--Oxygen | Range | 5-20.5% v/v | 5-20.5% v/v | 5-20.5% v/v | 20.9% v/v |
| | Default | 18% v/v | 18% v/v | 18% v/v | 20.9% v/v |
| GT3000--Carbon Monoxide | Range | 10-90% | 5-50% | 5-90% | 30-90% |
| | Default | 40% | 10% | 40% | 50% |
| GT3000--Sulfur Dioxide | Range | 10-90% | 5-50% | 5-90% | 30-90% |
| | Default | 40% | 10% | 40% | 50% |
| GT3000--Nitrogen Dioxide | Range | 10-90% | 5-50% | 5-90% | 30-90% |
| | Default | 40% | 10% | 40% | 50% |
| PIR9400 | Range | 10-60% | 5-50% | 5-90% | 50% |
| | Default | 40% | 10% | 40% | 50% |
| PIRDUCT | Range | 10-60% | 5-50% | 5-90% | 50% |
| | Default | 40% | 10% | 40% | 50% |
| PIRECL | Range | 10-60% | 5-50% | 5-90% | 30-90% |
| | Default | 40% | 10% | 40% | 50% |
| PIRECL - CO ₂ | Range | 10-60% | 5-50% | 5-90% | 30-90% |
| | Default | 40% | 10% | 40% | 50% |
| OPECL | Range | 1-3 LFL-meters | 0.25-3 LFL-meters | NA | NA |
| | Default | 2 LFL-meters | 1 LFL-meter | NA | NA |
| C7064E* | Range | 10-90% | 5-50% | 5-90% | 30-90% |
| | Default | 40% | 10% | 40% | 50% |
| CGS Combustible | Range | 10-60% | 5-50% | 5-90% | 50% |
| | Default | 40% | 10% | 40% | 50% |
| Model 505/CGS Combustible | Range | 10-60% | 5-50% | 5-90% | N/A |
| | Default | 40% | 10% | 40% | N/A |
| NTMOS--Hydrogen Sulfide | Range | 10-90% | 5-50% | 5-90% | 50% |
| | Default | 40% | 10% | 40% | 50% |
| Generic Detector | Range | 10-90% | 5-50% | 5-90% | N/A |
| | Default | 40% | 10% | 40% | 50% |
| LS2000 | Range | 0.5-4.5 LFL-meters | 0.5-4.5 LFL-meters | 0.5-4.5 LFL-meters | 1.5-4.5 LFL-meters |
| | Default | 3 LFL-meters | 1 LFL-meter | 3 LFL-meters | 2.5 LFL-meters |

Notes: All values are a **percentage of full scale** with the exception of Oxygen, which is the actual percent of Oxygen, and models OPECL and LS2000, which are the value in LFL-meters.

Low alarm must be less than or equal to the high alarm.

Changing the Measurement Range will reset all alarm and Cal Gas values to the default settings for the selected range.

Alarm relays are selectable for either normally energized or normally de-energized coils, with selectable latching or non-latching contacts. Fault relay is normally energized (with no faults).

When the auxiliary relay is set for latching and the gas level goes above the auxiliary alarm threshold, the 4-20 mA output will latch to the highest gas level detected until it is reset. When CGS mode is selected, the default setting for the auxiliary relay is a threshold of 90% full scale, with latching output.

*Does not support C7064C hydrogen sulfide or C7065E oxygen, but includes C7064E hydrogen sulfide, C7067E chlorine, C7066E carbon monoxide, and C7068E sulfur dioxide.

HART COMMUNICATION

A HART interface provides device status information and field programming capability.

MAGNETIC SWITCHES

Four internal magnetic switches provide a non-intrusive user interface that allows navigation through the menu and adjustment of configuration parameters in the field without the use of a HART handheld device. See Figure 1 for switch locations.

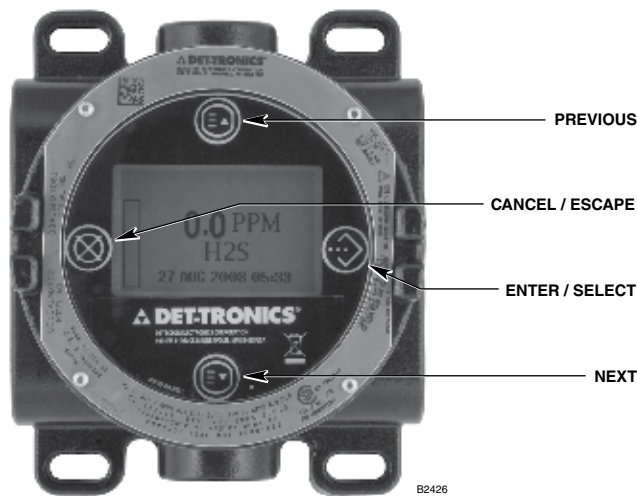





To actuate a magnetic switch, lightly touch the magnet to the viewing window of the UD10 directly over the switch icon on the faceplate.

CAUTION

Handle magnets with care! Personnel wearing pacemakers/defibrillators should not handle magnets. Modern magnet materials are extremely strong magnetically and somewhat weak mechanically. Injury is possible to personnel, and magnets themselves can easily get damaged if allowed to snap towards each other, or if nearby metal objects are allowed to be attracted to the magnets.

These switches are used for device configuration, checking status and event logs, and performing calibration. The switches are labeled as follows:

-  CANCEL / ESCAPE
-  ENTER / SELECT / MENU ACCESS
-  PREVIOUS or if on Main Screen:
Fault Shortcut
-  NEXT

NOTE

Det-Tronics offers two magnet options for activating internal magnetic switches. While the two magnets can usually be used interchangeably, the best results will be achieved if they are used as follows: The Magnetic Tool (p/n 009700-001) is the stronger magnet and is recommended for activating the switches on the UD10 viewing window. The Calibration Magnet (p/n 102740-002) is recommended for applications that involve initiating calibration or resetting the detector by touching the side of a metal junction box or detector housing (PIRECL, OPECL, etc). Throughout this manual, the term “magnet” can refer to either device.

GAS LEVEL INDICATION

The UD10 display will show a plus sign “+” to the right of the indicated value (i.e., 100+%LFL, 1000+PPM), to indicate an over-range. During an under-range condition, the display continues to show 0%LFL or 0PPM. Actual sensor signal / gas level can be examined using display to check the device (sensor) “PROCESS VARS” > ANALOG INPUT XX.XX mA to check an actual device output. Refer to the appropriate appendix for the attached sensor type.

SPECIAL STATES

Special states other than warm-up, normal operation, and fault require user action for activation. These include calibration, configuration, and parameter indication / verification. See Table 2.

Table 2—Special States

| STATE | UD10 Analog Output | | Visual Display | Relays | |
|-------------|--------------------|----------------|---|-----------|---|
| | Standard Mode | Replicate Mode | | Fault | Alarm(s) |
| Warm up | 3.5mA | Same as sensor | “WARM UP” | Off | <i>Reference Table 1 Alarm Data</i> |
| Calibration | 3.8mA | | “CALIBRATION” initially, then each calibration step | Off | |
| Fault | ≤3.6 | | FAULT | ON | |
| Alarm(s) | 4-20mA | | LOW, AUX, HIGH ALARM | Off | |

Access To Menus

To access the menus, use the magnet to activate the ENTER/SELECT button. This will display the Main Menu.

The actual menu structure varies depending upon the device that is connected to the UD10. Menus for the various devices can be found in the corresponding appendix in this manual.

Some areas of the menu contain additional information, which is indicated by the presence of an arrow on that particular line. By placing the magnet to the glass over the ENTER/SELECT button, the next screen with the additional information will be shown.

The UD10 automatically returns to the main screen after 10 minutes if no activity occurs.

Quick Access/Shortcut: Fault Menu

To access the fault menu quickly, when a fault is present, touch the magnet to the glass by the PREVIOUS button.

RELAYS

The display unit has 4 output relays — high alarm, low alarm, auxiliary alarm, and fault. The relays have form C (SPDT) contacts. Low, auxiliary, and high alarm relay contacts are selectable for latching or non-latching operation, as well as normally energized or normally de-energized (default) coils. During normal operation, the fault relay is energized.

IMPORTANT

Direct connection of 120/240 VAC to the relay terminals inside the UD10 enclosure is not allowed, since switching relay contacts can induce electrical noise into the electronic circuitry, possibly resulting in a false alarm or other system malfunction. If the application requires that AC powered equipment be controlled by the transmitter, the use of externally located relays is recommended.

External relays, solenoids, motors, or other devices that can cause inductive transients should be transient suppressed. Place a diode across the coil for DC devices. See Figure 2.

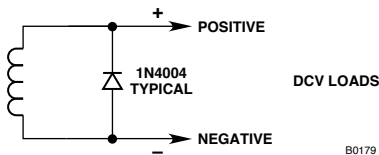

Figure 2—Transient Suppression for Inductive Loads

4-20 MA OUTPUT MODES

The UD10 offers two operating modes for its 4-20 mA output circuit.

NOTE

A minimum output of 1 mA is required for proper HART communication.

In the **Standard (default) Mode**, the linear 4-20 mA output corresponds to 0-100% full scale gas detected at the sensor, with 3.8 mA indicating calibrate mode, and 3.6 mA or lower indicating a fault condition. This mode ensures that the current level is always high enough to support HART communication and must be selected when using HART communication for fault diagnostics.

In **Replicate Mode**, the output of the UD10 matches the output of the connected detector (except for loop test/trim, response test, calibration, or if the UD10 has an internal fault). This mode can be used with

detectors such as PIR9400 or PIRECL where multiple current levels below 4 mA are used for fault diagnostic purposes.

UD10 with Model PIRECL

PIRECL supports two fault modes: PIR9400 and Eclipse mode. PIR9400 fault mode uses fault codes below 1 mA, while Eclipse mode uses no levels below 1 mA. In the Standard (default) mode, the UD10 programs the PIRECL for Eclipse fault mode to ensure proper HART communication in the event of a fault. In the Replicate mode, the UD10 programs the PIRECL for PIR9400 fault mode.

MODBUS COMPATIBILITY

The UD10 supports RS485 Modbus RTU communication. See Addendum number 95-8639 for details.

DEVICE ENCLOSURE

The UD10 housing is a 5 port aluminum or stainless steel explosion-proof junction box with a clear viewing window.

DEVICE DISPLAY

The UD10 is provided with a 160 x 100 dot matrix backlit LCD display. See Figure 1.

During normal operation, the LCD continuously displays the detected gas level, gas type, and units of measurement. The real time clock can also be displayed if desired.

The display shows the following alarm information:

- High gas alarm
- Low gas alarm
- Aux alarm

The display indicates the following fault information:

- Device fault
- Display fault

The UD10 has smart capabilities to allow easy access to the following information:

- Detector information
- Measurement range
- Alarm setpoints
- Alarm and event logs

For detailed HART menu structure, refer to the appropriate appendix.

LOGGING

Events that can be logged in the UD10 include:

- Calibration (Date, time, and success Y/N are logged for detectors that do not provide their own calibration logging capabilities.)

Faults that are logged in the UD10 include:

- Detector fault
- Low power
- General fault

Alarms that are logged in the UD10 for gas detector inputs include:

- High gas alarm
- Low gas alarm
- Aux alarm.

The UD10 has its own battery backed real time clock (RTC) and its own event logs. The RTC in the UD10 can be set from the UD10 display, Modbus or HART interfaces. The RTC in the gas detector (any HART detector having an RTC) can be set independently using the UD10 menu, or by using the synchronize command, which will set the detector RTC to the same time as the UD10 RTC. See Figure 3.

The UD10 can display the detector event and calibration logs (if available). The UD10 has its own 1,000-entry event log available under the Display Status->History->Event Log menu.

UD10 event logs can be read from the HART interface or the Modbus interface.

Detector calibration and event logs can also be read from the detector HART interface (where available).

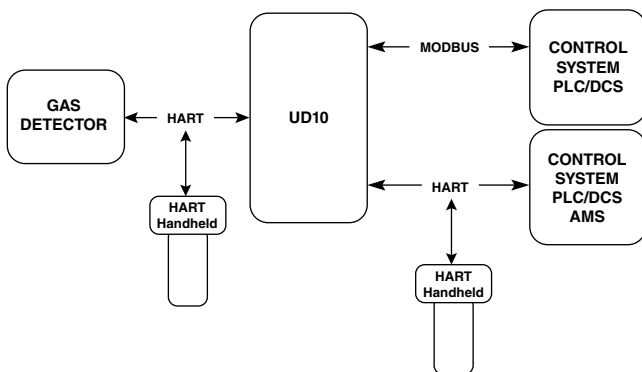

Figure 3—UD10 Logging

IMPORTANT SAFETY NOTES

⚠ CAUTION

The wiring procedures in this manual are intended to ensure proper functioning of the device under normal conditions. However, because of the many variations in wiring codes and regulations, total compliance to these ordinances cannot be guaranteed. Be certain that all wiring complies with the NEC as well as all local codes. If in doubt, consult the authority having jurisdiction before wiring the system. Installation must be done by a properly trained person.

⚠ CAUTION

This product has been tested and approved for use in hazardous areas. However, it must be properly installed and used only under the conditions specified within this manual and the specific approval certificates. Any device modification, improper installation, or use in a faulty or incomplete configuration will render warranty and product certifications invalid.

⚠ CAUTION

The device contains no user serviceable components. Service or repair should never be attempted by the user. Device repair should be performed only by the manufacturer.

LIABILITIES

The manufacturer's warranty for this product is void, and all liability for proper function of the detector is irrevocably transferred to the owner or operator in the event that the device is serviced or repaired by personnel not employed or authorized by Detector Electronics Corporation, or if the device is used in a manner not conforming to its intended use.

⚠ CAUTION

Observe precautions for handling electrostatic sensitive devices.

⚠ CAUTION

Unused conduit entries must be closed with suitably certified blanking elements upon installation.

INSTALLATION

NOTE

The gas detector housing must be electrically connected to earth ground. A dedicated earth ground terminal is provided on the UD10.

NOTE

Refer to the Model UD10 Safety Manual, number 95-8668, for specific requirements and recommendations applicable to the proper installation, operation, and maintenance of SIL-Certified Model UD10 displays.

The detector must always be installed per local installation codes.

Before installing the gas detector, define the following application details:

IDENTIFICATION OF VAPOR(S) TO BE DETECTED

It is necessary to identify the vapor(s) of interest at the job site. The fire hazard properties of the vapor, such as vapor density, flashpoint, and vapor pressure should be identified and used to assist in selecting the optimum detector mounting location within the area.

For cross sensitivity information, refer to each gas detector's corresponding instruction manual. Refer to Table 6 in the "Specifications" section for a list of gas detectors and their corresponding instruction manuals.

Table 3—Device Orientation

| Device | Orientation |
|------------------------|------------------------------------|
| GT3000 | Vertical with Sensor Pointing Down |
| PIR9400 | Horizontal |
| PIRDUCT | Horizontal |
| PIRECL | Horizontal |
| PIRECL-CO ₂ | Horizontal |
| OPECL | Horizontal |
| CGS | Vertical with Sensor Pointing Down |
| 505/CGS | Vertical with Sensor Pointing Down |
| C706X | Vertical with Sensor Pointing Down |
| NTMOS | Vertical with Sensor Pointing Down |
| Acoustic | Vertical with Sensor Pointing Down |
| LS2000 | Horizontal |

IDENTIFICATION OF DETECTOR MOUNTING LOCATIONS

Identification of the most likely leak sources and leak accumulation areas is typically the first step in identifying the best detector mounting locations. In addition, identification of air current/wind patterns within the protected area is useful in predicting gas leak dispersion behavior. This information should be used to identify optimum detector installation points.

If the vapor of interest is lighter than air, place the detector above the potential gas leak. Place the detector close to the floor for gases that are heavier than air. Note that air currents may cause a gas that is slightly heavier than air to rise under some conditions. Heated gases may also exhibit the same phenomenon.

The most effective number and placement of detectors varies depending on the conditions on site. The individual designing the installation must often rely on experience and common sense to determine the detector quantity and best locations to adequately protect the area. Note that it is typically advantageous to locate detectors where they are accessible for maintenance. Locations near excessive heat or vibration sources should be avoided.

Final suitability of possible gas detector locations should be verified by a job site survey.

The gas detector must be mounted with the sensor in the correct orientation as shown in Table 3.

If the UD10 faceplate is not correctly oriented, it can be rotated at 90 degree increments by pulling the electronic module from the four mounting posts that secure it to the junction box and repositioning it as desired. Note that the module is held in place by a compression fitting – no screws are involved.

WIRING

POWER SUPPLY REQUIREMENTS

Calculate the total gas detection system power consumption rate in watts from cold start-up. Select a power supply with adequate capability for the calculated load. Ensure that the selected power supply provides regulated and filtered 24 Vdc output power for the entire system. If a back-up power system is required, a float-type battery charging system is recommended. If an existing source of 24 Vdc power is being utilized, verify that system requirements are met. The acceptable voltage range is 18-30 Vdc measured at the input to the UD10.

NOTE

The power supply must meet the noise requirements for HART systems. If noise or ripple on the main power source could interfere with the HART function, an isolated power source (Figure 11) is recommended. (For detailed information regarding power supply specifications, refer to the HART Communication Foundation's document "FSK Physical Layer Specification" HCF_SPEC-54.)

WIRING CABLE REQUIREMENTS

Always use proper cabling type and diameter for input power as well as output signal wiring. 14-18 AWG, 2.5–0.75 mm² shielded stranded copper wire is recommended. Correct wire size depends on the device and wire length. Refer to the appropriate appendix for additional information. The maximum cable length from power source to UD10 is 2000 feet. Maximum cable length from UD10 to sensor is 2000 feet.

NOTE

The use of shielded cable in conduit or shielded armored cable is highly recommended. In applications where the wiring is installed in conduit, dedicated conduit is recommended. Avoid low frequency, high voltage, and non-signaling conductors to prevent nuisance EMI problems.

CAUTION

The use of proper conduit installation techniques, breathers, glands, and seals is required to prevent water ingress and/or maintain the explosion-proof rating.

SHIELD CONNECTIONS

The UD10 provides terminals for proper grounding of wiring cable shields (located on the sensor, 4-20 mA, and operating power terminal blocks). These shield terminals are not connected internally, but are connected to ground through capacitors. The capacitors ensure an RF ground, while preventing 50/60 Hz ground loops.

Ground all shields as shown in the wiring examples throughout this manual.

IMPORTANT

For proper grounding, all junction boxes / metal enclosures must be connected to earth ground.

The following are required for installations requiring CE Mark compliance:

- For shielded cable installed in conduit, attach the wire shields to the "shield" connections on the terminal blocks, or to earth ground on the case.
- For installations without conduit, use double shielded cable. Terminate the outer shield to earth ground on the case. Terminate the inner shield to the "shield" connection on the terminal blocks.

JUMPER SETTING FOR 4-20 MA LOOP

In order for the 4-20 mA current loop to operate properly, +24 Vdc must be applied to terminal P1-3. This can be accomplished in one of two ways:

- For a **non-isolated** 4-20 mA loop, set jumper plug as shown in Figure 4. This applies +24 Vdc to P1-3 via an internal connection to terminals P2-2 and P2-5.
- If the 4-20 mA loop will receive power from a source other than the UD10's main power source (**isolated**), set the jumper plug as shown in Figure 5 to remove the internal connection.

WIRING PROCEDURE

NOTE

The following section shows the output of the UD10 wired to a generic 4-20 mA signal receiver in various configurations. Since the UD10 can be used with a variety of different detection devices, information that is specific to each detector model (wiring, calibration, HART menus, etc.) is covered in an appendix that is dedicated to that device. Refer to the appropriate appendix at the back of this manual for specific information when wiring the detection system. For information on devices not covered in an appendix, refer to the manual provided by the device's manufacturer.

Figure 4 shows jumper plug P12 positioned to power the 4-20 mA loop from the main power source (non-isolated output).

Figure 5 shows jumper plug P12 positioned for powering the 4-20 mA loop from an external wire/jumper of from a separate power source (isolated output).

Figure 7 shows a UD10 Wired to a PLC using 3-Wire Shielded Cable with a 4-20 mA Non-Isolated Sourcing Output.

Figure 8 shows a UD10 Wired to a PLC using 4-Wire Shielded Cable with a 4-20 mA Non-Isolated Sourcing Output.

Figure 9 shows a UD10 Wired to a PLC with a 4-20 mA Isolated Sourcing Output.

GREASE/LUBRICATION

To ease installation and future removal, ensure that all junction box covers and sensor threads are properly lubricated. If the need arises for additional lubrication, use either Lubriplate grease (see Ordering Information for part number) or Teflon tape. Avoid the use of silicone grease.

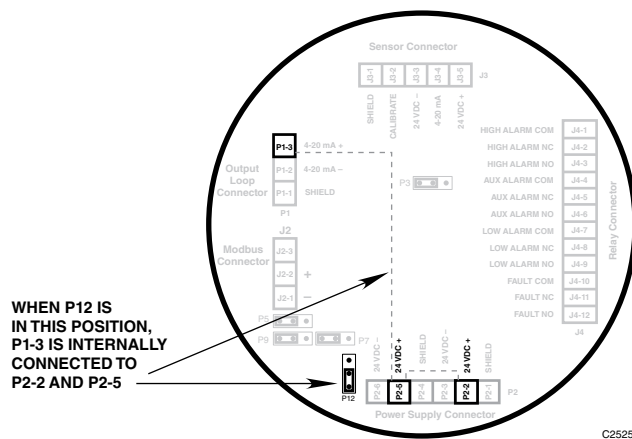

Figure 4—Position of Jumper P12 for Non-Isolated 4-20 mA Loop Output

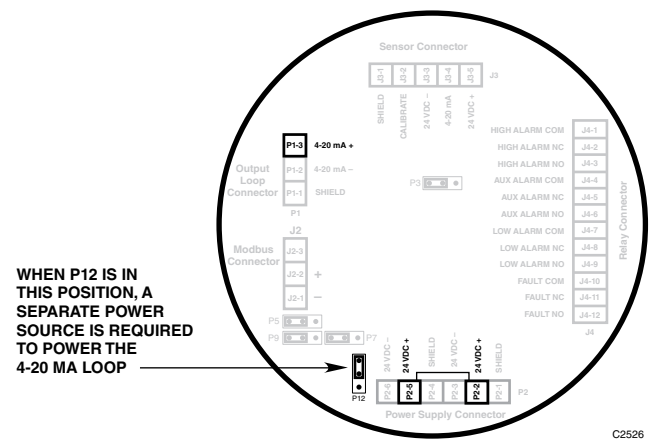
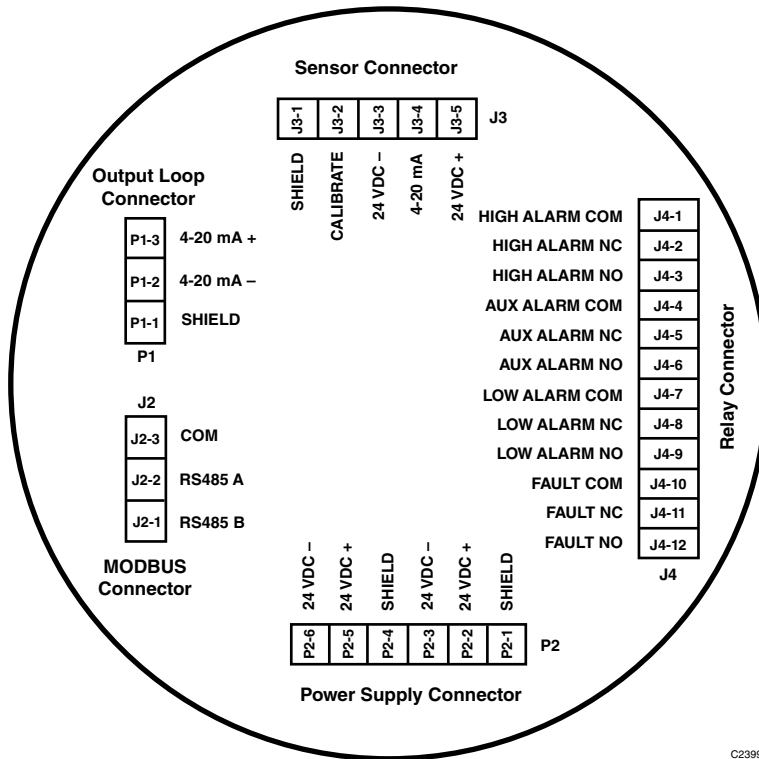
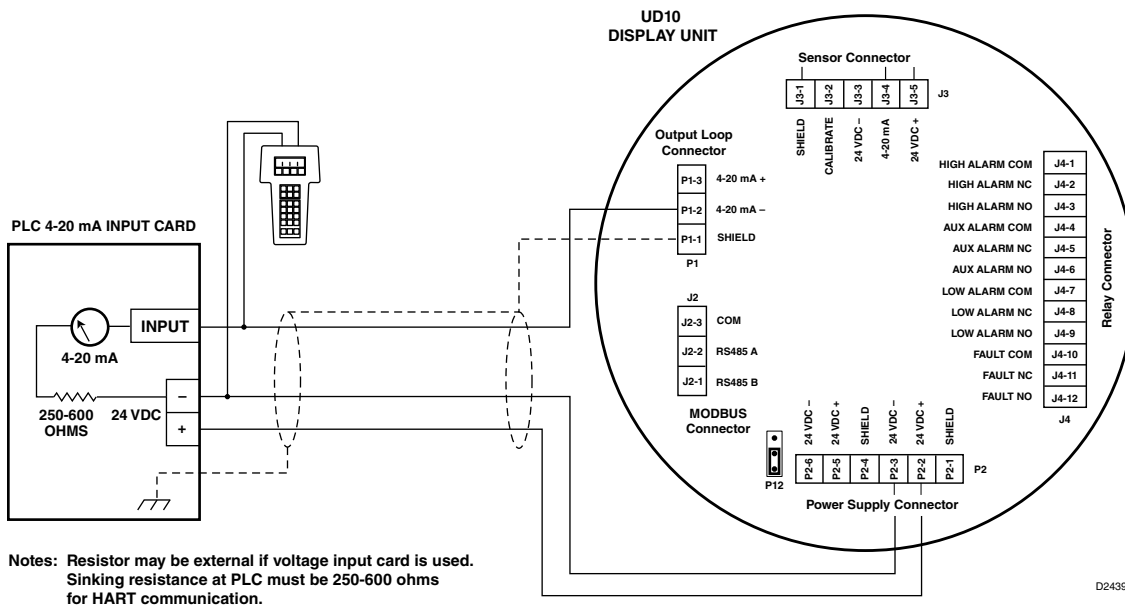

Figure 5—Position of Jumper P12 for Isolated 4-20 mA Loop Output



C2399

Figure 6—Wiring Terminals on UD10 Terminal Board



D2439

Figure 7—UD10 Wired to PLC using 3-Wire Shielded Cable with 4-20 mA Non-Isolated Sourcing Output

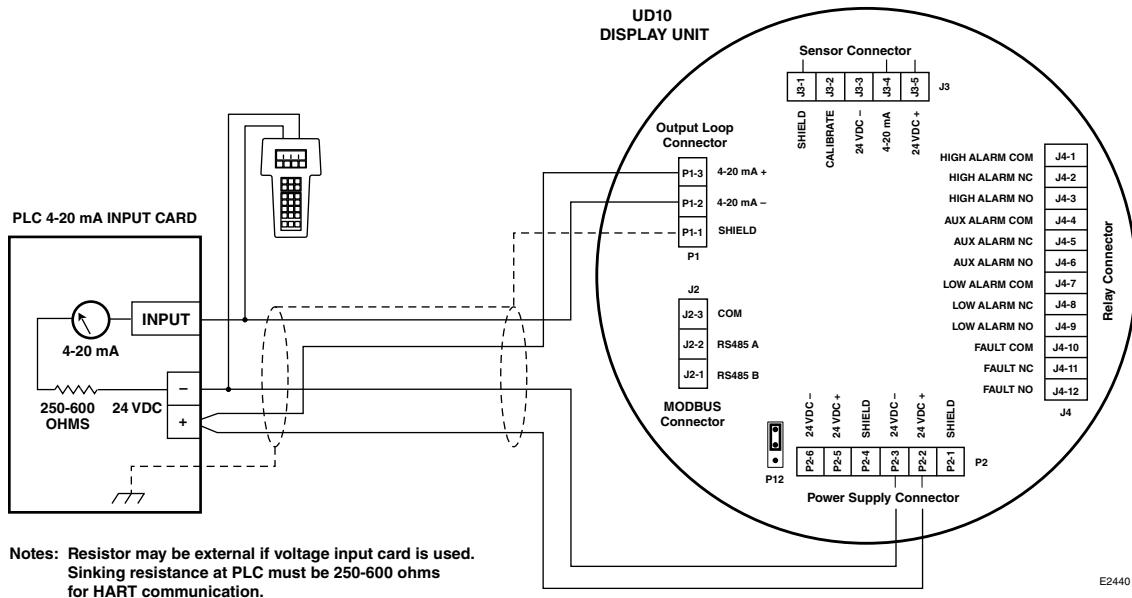

Figure 8—UD10 Wired to PLC using 4-Wire Shielded Cable with 4-20 mA Non-Isolated Sourcing Output

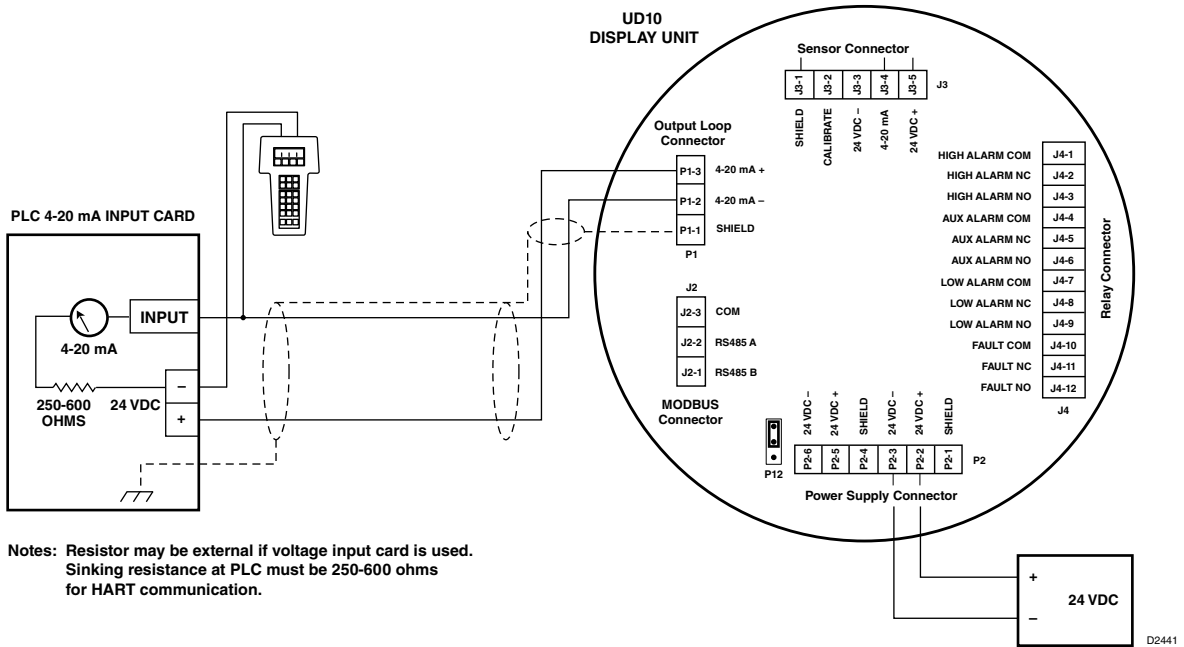

Figure 9—UD10 Wired to PLC with 4-20 mA Isolated Sourcing Output

IMPORTANT

Isolated operation is highly recommended to prevent noise or ripple on the main power source from interfering with the HART function.

STARTUP

After power has been applied and the warm-up period is complete, select the UD10 operating mode. To do this:

1. Access the Main Menu by touching the magnet to the ENTER/SELECT button. From there, navigate to the "Mode Select" menu.

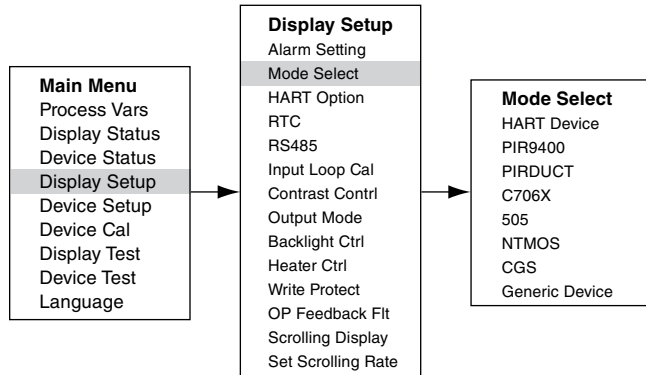

2. From the "Mode Select" menu, select and enter the appropriate operating mode based on the type of detector being used.

NOTE

If using a PIR9400, note that changing the gas type on the UD10 does not change the gas type at the PIR9400. This change is made using a switch located in the PIR9400. Refer to the PIR9400 instruction manual 95-8440 for details.

NOTE

If using a C706X detector, navigate to the "Device Setup" menu and select the appropriate gas type and unit of measurement.

3. To exit, activate CANCEL/ESCAPE three times to return to the main display screen.
4. If the detector is replaced with another detector type, the UD10 will not recognize it until the mode is changed.
5. If the UD10 Display is in PIR9400 mode and if:
 - a. The connection between PIR9400 and the UD10 is removed, the UD10 will show a FAULT on the Gas Screen. When the connection between PIR9400 and UD10 is restored, the UD10 will remove the FAULT indication when current increases beyond 3.6 mA.
 - b. Someone removes the PIR9400 & connects a HART enabled Gas Detector, it will not be recognized by the UD10 Display until the mode is changed to HART.

RTC

NOTE

The UD10 is set at the factory for US Central Standard time.

To display and set the Real Time Clock and Date for the UD10:

1. Using the magnet to activate the switches on the UD10 display, navigate to the RTC menu.

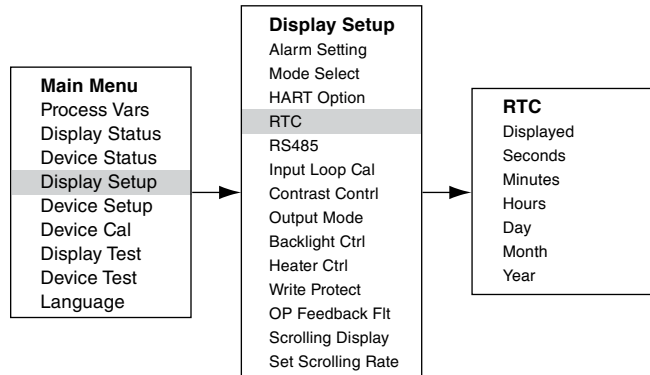

2. The first item on the RTC screen is "Displayed". Y (Yes) or N (NO) is shown to indicate whether the time and date will be displayed on the main screen. To change the display setting, use the ENTER/SELECT button to go to the next screen, then use the PREVIOUS or NEXT buttons to toggle between Y and N. Once the chosen input is selected, use the ENTER/SELECT button to enter the selection. Use the CANCEL/ESCAPE button to exit without changing.

3. Use the same method to set time and date.

Specifically for the GT3000 Transmitter, the RTC for the transmitter can be synchronized to the RTC of the display by going through the Main Menu->Device Setup->RTC-> 1st slot "Sync W/Disp."

Latching Alarms

The high, auxiliary and low alarm relay settings are programmable and can be set for latching or non-latching operation. Alarm configuration can be done using the local display menu or external HART interface. Latched alarms on the display can be cleared:

- Through the Display Setup > Alarm Setting submenu using the magnet or external HART interface.
- Using the Cancel button on the UD10 faceplate.
- Using the Calibration line if it is not used by the attached detector.

4-20 mA LOOP CALIBRATION

Both the input and output current loops of the UD10 are trimmed at the factory. They can also be trimmed in the field for maximum accuracy using the following procedures. If the detector connected to the UD10 is HART enabled, its 4-20 mA output signal can also be trimmed.

When the UD10 is used with a detector that supports HART communication, the output of the detector should be calibrated first.

HART Detector Signal Calibration

Navigate down the menu to Device Test > D/A (Digital to Analog) Trim.

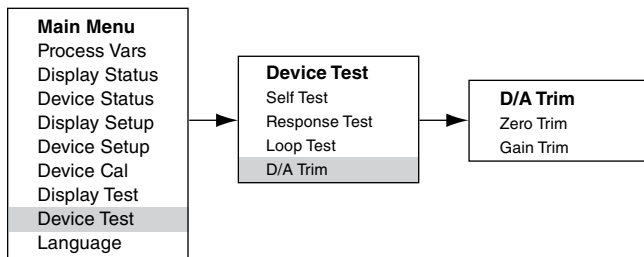

Select Zero Trim. When this screen is entered, a warning message is presented. Select ENTER to continue. When the message “Connect Reference Meter” is presented, install the current meter on the mA line between the detector and UD10. Select ENTER to continue. When the message “Set Input Current to 4mA?” is presented, select ENTER to begin the Zero Trim function. The detector will now set its 4 mA output value. If the value indicated on the current meter is not 4.00 mA, enter the measured value into the UD10 using the Previous and Next switches. The UD10 calculates and corrects for the difference between the actual and entered values. When the current meter value is at the desired 4.00 mA, select ENTER to accept the new Zero Trim value.

Select Gain Trim. Follow the same procedure for gain/span calibration.

UD10 Input Trim

When the UD10 is used with a detector that supports HART communication, an automated process can be used to trim the UD10 input. Navigate down the menu to “Input Loop Cal”.

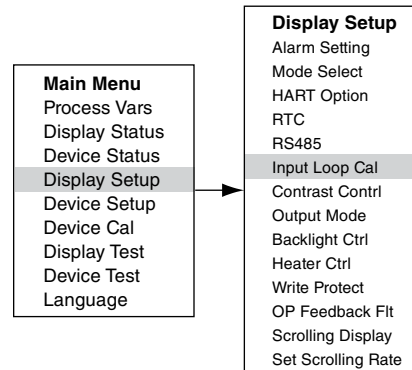

Upon entering Input Loop Cal, the UD10 commands the detector to output 4 mA, and then automatically calibrates its own input. The UD10 then commands the detector to output 20 mA and subsequently calibrates its own input.

If a non-HART detector is being used, the Input Loop Cal may be performed with a mA current source or loop calibrator connected to the UD10 Sensor Connector. Follow the loop calibration instructions shown by the UD10 for this procedure.

UD10 Output Trim

To calibrate the UD10 output loop, navigate down the menu to Display Test > D/A Trim.

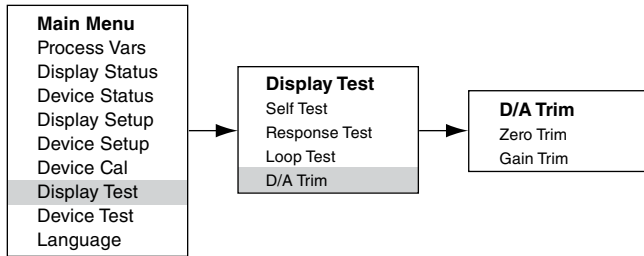

Select Zero Trim. When this screen is entered, a warning message is presented. Select ENTER to continue. When the message “Connect Reference Meter” is presented, install the current meter on the UD10 mA output. Select ENTER to continue. When the message “Set Output Current to 4mA?” is presented, select ENTER to begin the Zero Trim function. The UD10 will now set its 4 mA output value. If the measured value on the current meter is not 4.00 mA, enter the measured value into the UD10 using the Previous and Next switches. The UD10 calculates and corrects for the difference between the actual and entered values. When the current meter value is at the desired 4.00 mA, select ENTER to accept the new Zero Trim value.

Select Gain Trim. Follow the same procedure for gain/span calibration.

OPTIONAL SYSTEM TESTS

The following tests are available for verifying proper operation of various functions of the gas detection system:

- The Self Test, Response Test, and Loop Test are accessed from the “Display Test” screen. (A “Device Test” screen is available for performing the same tests on HART enabled detectors.)
- The Proof Test is performed by applying test gas to the sensor. It is **not** accessed from the “Display Test” screen and does **not** inhibit the outputs.

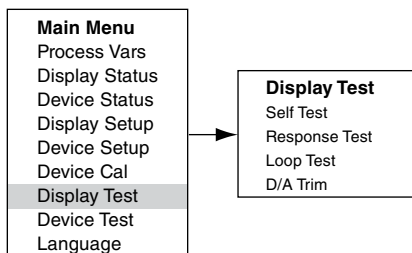

Self-Test

This test commands the UD10 to perform a fully automatic internal test. At the completion of the test, the UD10 will indicate a pass or fail.

Response Test

This test inhibits the UD10’s outputs, thereby providing a means of testing the system by applying gas to the detector without activating any alarms or affecting the output.

NOTE

If the Response Test is not terminated by the operator, the test will automatically time out after 10 minutes and the UD10 will return to normal operation.

Loop Test

This test temporarily forces the UD10’s 4-20 mA output to a specific level. This is an easy way to test the output signal of the UD10 for accuracy, to verify the capabilities of the system, and to verify the input signal of a receiver. To perform this test, connect a current meter to the output loop. Navigate to Display Test and select Loop Test, then follow the prompts on the UD10 Screen.

NOTE

If the Loop Test is not terminated by the operator, the test will automatically time out after one minute and the UD10 will return to normal operation.

Proof Test

A Proof Test (bump test) can be performed at any time to verify proper operation and calibration of the system. Since this test does not inhibit the UD10’s outputs, secure any output devices prior to performing the test to prevent unwanted actuation.

HISTORY

There are two separate histories, one for the display and one for the detector (if available). Both will state the number of hours that the unit has been operating, and the highest and lowest recorded temperature (with time and date stamp).

PASSWORD PROTECTION

The UD10 allows the use of a password for restricting changes to configuration parameters and limiting access to safety critical commands. The UD10 is shipped from the factory with the password protection (Write Protect) feature disabled.

The following are locked when Write Protect security is enabled:

Alarm Setting screen – All options except “RST Latch Alarms”

Mode Select screen – All options

HART Option – All options

RTC – All options except Displayed Y/N

Output Mode

Display Test screen – All options

To enable the Write Protect feature, navigate to the Write Protect screen.

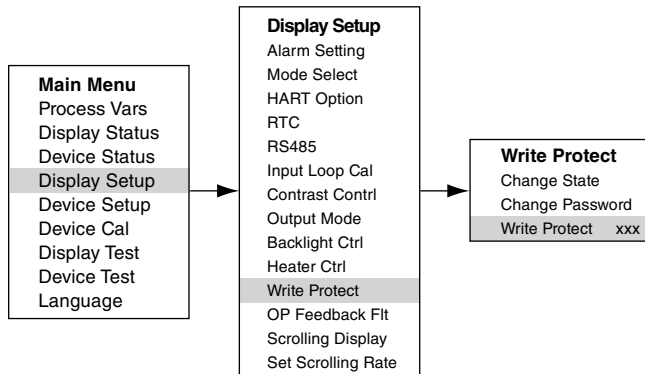

Select “Change State” to toggle between Enabled and Disabled.

Select “Change Password” to enter a new password.

“Write Protect” indicates whether password protection is Enabled or Disabled.

The default password is 1*****.

IMPORTANT

Take care not to lose the password. Future changes cannot be made without a password.

DISPLAY BACKLIGHT OPERATION

The UD10 can be programmed to turn on the backlight feature of the digital display when an alarm or fault occurs or a magnetic switch is activated. Navigate to the Backlight Ctrl screen.

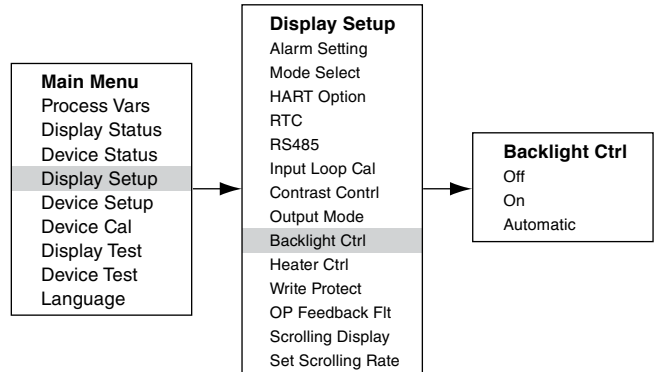

Off = The backlight is always off.

On = The backlight is always on.

Automatic = Normal operation – Backlight is off
 Alarm – Backlight flashes on and off
 Fault – Backlight is on steady
 Magnetic Switch – Backlight is on steady

The backlight automatically turns off 10 minutes after the last Magnetic Switch activation.

If the backlight is on following a magnetic switch activation and then an alarm condition occurs, the backlight will remain on steady and not flash until the 10 minute time-out is complete. Then it will begin flashing.

TROUBLESHOOTING

If a Fault condition is indicated on the UD10 faceplate, the nature of the fault can be determined by using the magnetic tool to navigate to the appropriate Fault screen.

NOTE

Refer to the Menu in the appropriate appendix of this manual for the path to the proper Fault screen.

Shortcut: From the main display screen, touch the magnet to the "Previous" switch to go directly to the Fault screen.

Example:

For a Display (UD10) related fault:

Main Menu > Display Status > Fault/Status > Fault

For a Device (Sensor) related fault:

Main Menu > Device Status > Fault/Status > Sensor Fault

When the active fault has been identified, refer to the Troubleshooting Tables for a description of the fault and suggested corrective action.

Refer to Table 4 for Display Faults and Table 5 for Device Faults.

Table 4—Troubleshooting Guide - Display Faults

| Display Faults | Description | Recommended Action |
|-----------------|---|---|
| Input Loop FLT | Fault in sensor or sensor loop | Check sensor wiring. Calibrate sensor. Ensure that sensor type matches configuration. |
| Output Loop FLT | Fault in 4-20 mA output loop | Check 4-20 mA loop wiring for shorts or opens. |
| EE Fault | Fault in non-volatile memory | Return to factory. |
| ADC Ref Fault | ADC reference voltage too high or low | Return to factory. |
| 24V Fault | Problem in 24 volt power supply or power wiring | Check power wiring and output voltage of power supply. |
| Flash Fault | FLASH memory Fault | Return to factory. |
| RAM Fault | Fault in volatile memory | Return to factory. |
| WDT Fault | Watchdog timer is non-functional | Return to factory. |
| 12V Fault | 12 volt internal power supply out of tolerance | Check power source. Return to factory. |
| 5V Fault | 5 volt internal power supply out of tolerance | Check power source. Return to factory. |
| 3V Fault | 3 volt internal power supply out of tolerance | Check power source. Return to factory. |

Note: A fault condition will cause an oxygen detector to generate an alarm output as the decreasing 4-20 mA signal passes through the alarm range.

Table 5—Troubleshooting Guide - Device Faults

| Device Faults | Description | Recommended Action |
|--------------------------|--|--|
| Loop Fault | Current loop below fault threshold | Check 4-20 mA loop wiring for shorts or opens. |
| Supply Voltage Fault | 24 volt power supply voltage too low | Verify proper wiring to the device and correct voltage output from the power supply. |
| Calibration Fault | Bad calibration | This fault can be caused if the calibration is allowed to time out. If so, recalibrate. Ensure that there is enough gas in the calibration bottle to complete the calibration. Ensure that the gas being used for calibration is the correct type and concentration. It must match the configured setting. |
| Memory Fault | Self-detected memory fault | Return to factory. |
| ADC Fault | Self-detected ADC fault | Return to factory. |
| Internal Voltage Fault | Self-detected voltage fault | Check supply voltage. Return to factory. |
| Zero Drift | Sensor signal has drifted negative | Device may have been calibrated with background gas present. Recalibrate the detector. Purge with clean air if needed. |
| Temperature Sensor Fault | Temperature sensor is out of range | Return to factory. |
| Wrong Sensor Type | Wrong sensor type is installed | Sensor type must match configuration. Change sensor or configuration. |
| Lamp Fault | Open or shorted lamp | Replace lamp. Return to factory. |
| Alignment Fault | Open path alignment problem | Align the device as specified in the instruction manual. |
| Blocked Optic Fault | Optical path is blocked | Locate and remove obstruction from the optical path. |
| Cal Line Active | Cal line is active at start-up | Ensure that the Cal line wiring is not shorted and the switch is open. |
| Low Cal Line | Cal line is shorted. | Check wiring. |
| Sensor Fault | Self-detected fault with the sensor | Check sensor wiring. Calibrate sensor. Ensure that sensor type matches configuration. |
| Noise Fault* | Excessive noise on signal | Check OPECL alignment. |
| Align ADC Fault* | Alignment ADC saturated | Check OPECL alignment. |
| Align Fault* | Alignment fault | Check OPECL alignment. |
| Align Warning* | Alignment warning | Check OPECL alignment. |
| DAC Fault | DAC fault detected | Return to factory. |
| General Fault | Unspecified fault | Verify correct power wiring and supply voltage. Consult the factory. |
| High Fault | Detector output is higher than specified limit | Verify correct sensor type and calibration. |
| Low Fault | Detector output is lower than specified limit | Verify correct sensor type and calibration. |
| Dirty Optics | Detector optics are dirty | Perform the cleaning procedure as described in the detector manual, then perform calibration. |
| Start Cal Fault | Calibration fault | Verify correct sensor type and calibrate. |

*OPECL only.

Table 5—Troubleshooting Guide - Device Faults, Continued

| Device Faults | Description | Recommended Action |
|----------------------|--|--|
| EE Fault | Fault in non-volatile memory | Power may have been interrupted while the device was updating its internal data logs. Recycle power. |
| Ref ADC Sat | Sensor signal level is outside the range of the AD converter | Return to factory. |
| Active ADC Sat | Sensor signal level is outside the range of the AD converter | Return to factory. |
| 24V Fault | Problem in 24 volt power supply or power wiring | Check power wiring and output voltage of power supply. |
| Flash CRC Fault | Memory fault | Return to factory. |
| RAM Fault | Fault in volatile memory | Return to factory. |
| Low Voltage | Power supply voltage outside of limits | Check power supply voltage. Return to factory. |
| Temp Fault | Temperature sensor fault | Return to factory. |
| Software Fault | Internal software fault | Return to factory. |
| EE Safety Fault | Internal configuration fault | Return to factory. |
| Gas Under Range | Sensor signal has drifted negative | Device may have been calibrated with background gas present. Recalibrate the detector. Purge with clean air if needed. |
| Sensor Mismatch | Wrong sensor type is installed | Sensor type must match configuration. Change sensor or configuration. |
| ADC CNTR Fault | Internal hardware fault | Return to factory. |
| 3V Fault | 3 volt internal power supply out of tolerance | Return to factory. |
| Comm Fault | Communication fault | Check detector wiring and power supply. |
| GEN Fault | Unspecified fault | Verify correct power wiring and supply voltage. Consult the factory. |
| 12V Fault | 12 volt internal power supply out of tolerance | Return to factory. |
| 5V Fault | 5 volt internal power supply out of tolerance | Return to factory. |

SPECIFICATIONS

OPERATING VOLTAGE—

24 Vdc nominal, operating range is 18 to 30 Vdc.
Ripple cannot exceed 0.5 volt P-P.

OPERATING POWER—

Standard model, with heater and backlight off:

No alarm: 1.5 watts @ 24 Vdc.
Alarm: 3 watts @ 24 Vdc (20 mA current loop output and all 3 alarm relays energized.)

Backlight on: 0.5 watt additional.
Heater on: 3.5 watts additional.
CGS model: Add 4 watts with CGS interface board and CGS sensor installed.

Maximum power in alarm, with heater and backlight on:
7 watts @ 30 Vdc (Standard model)
11 watts @ 30 Vdc (CGS model)

NOTE

Heater turns on when the internal temperature drops below -10°C (default operation). Heater function can be disabled to save power.

NOTE

Appropriate relays will be activated when a fault or alarm occurs.

CURRENT OUTPUT—

Linear isolated 4-20 mA output with HART.
3.8 mA indicates calibrate mode.
3.6 mA or less indicates a fault condition.
Maximum loop resistance is 600 ohms at 18 to 30 Vdc.

CURRENT OUTPUT RESPONSE TIME—

Toxic gas mode: T90 \leq 5 seconds.
Combustible gas mode: T90 \leq 4 seconds.
Combustible gas - open path mode: T90 \leq 4 seconds.
UD10 w CGS: T90 <12 seconds.

CURRENT OUTPUT ACCURACY: GENERAL—

The UD10 adds less than 1% error to the output value.

SYSTEM OUTPUT ACCURACY: UD10 WITH CGS—

The UD10 with CGS sensor directly attached has an overall system accuracy of $\pm 3\%$ for 0-50 LFL range and $\pm 5\%$ for 51-100 LFL range, including error added by UD10.

RELAY CONTACTS—

Three Alarm Relays: Form C, 5 amperes at 30 Vdc.
Selectable energized/de-energized.
Selectable latching or non-latching.
Refer to Table 1 for range and default settings.

WARNING

When in non-latching mode, the control device must latch the alarm output.

One Fault Relay: Form C, 5 amperes at 30 Vdc.
Normally energized for no fault condition with power applied.

RELAY RESPONSE TIME—

\leq 2 seconds.

WIRING TERMINALS—

14–18 AWG, 2.5–0.75 mm² wire can be used.

OPERATING TEMPERATURE—

-55°C to $+75^{\circ}\text{C}$

STORAGE TEMPERATURE—

-55°C to $+75^{\circ}\text{C}$

HUMIDITY RANGE—

5 to 95% RH (Det-Tronics verified)

ELECTRO-MAGNETIC COMPATIBILITY—

EMC Directive 2014/30/EU
EN 50270:2006
EN 61000-6-2:2005
EN 61000-6-4:2007

DIMENSIONS—

See Figures 10 and 11.

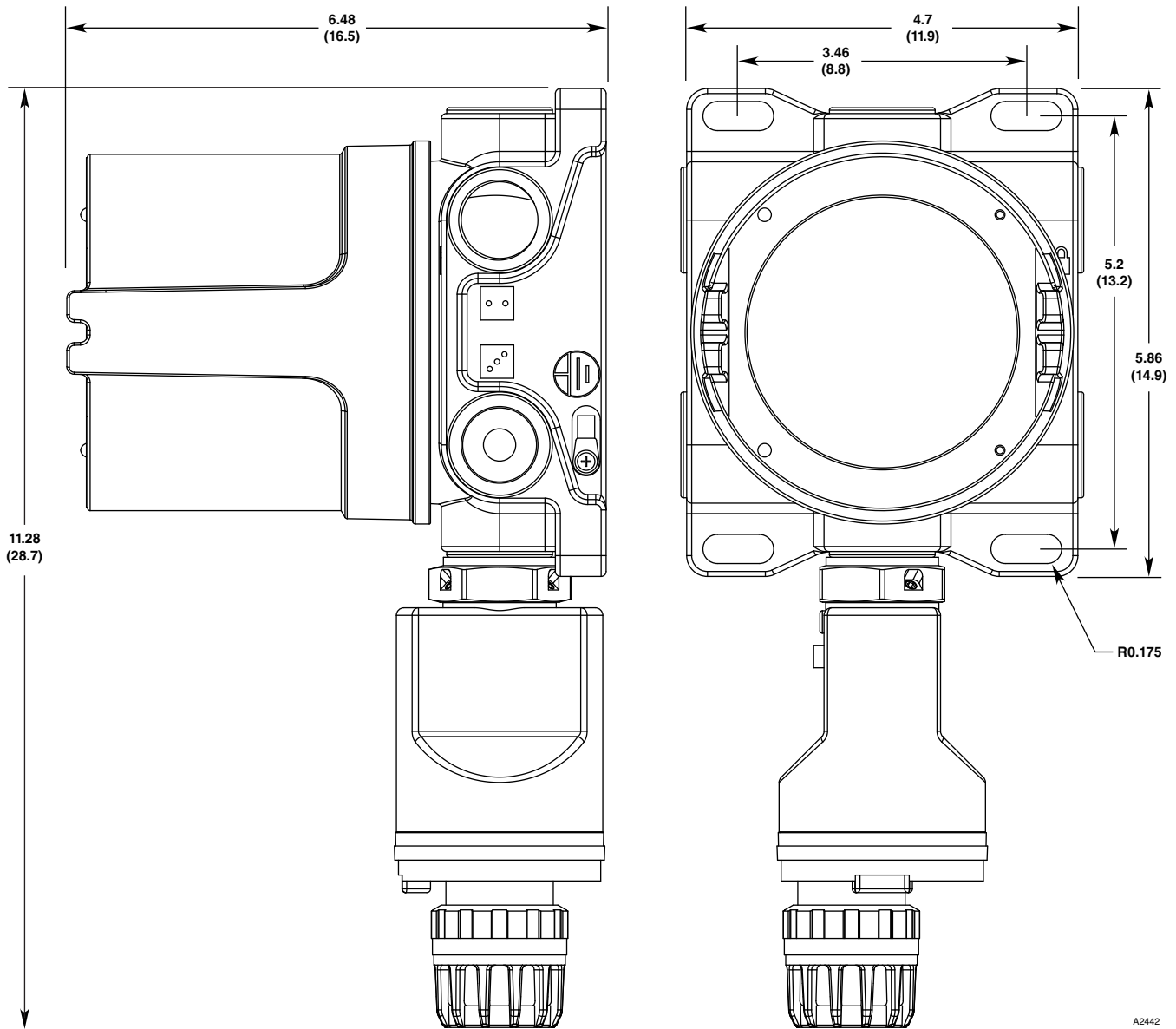

Figure 10—Dimensions of UD10 with GT3000 in Inches (Centimeters)

CONDUIT ENTRIES—

3/4" NPT or M25

ENCLOSURE MATERIAL—

Epoxy coated aluminum or 316 stainless steel.

SHIPPING WEIGHT—

Aluminum: 4.15 pounds (1.88 kilograms)

Stainless steel: 10.5 pounds (4.76 kilograms)

WARRANTY—

12 months from date of installation or 18 months from date of shipment, whichever occurs first.

DETECTOR COMPATIBILITY—

The UD10 can be used with the Det-Tronics gas detectors listed in Table 6.

UNIT OF MEASUREMENT—

PPM, % LFL, % V/V, LFLM, or Mg/M³.

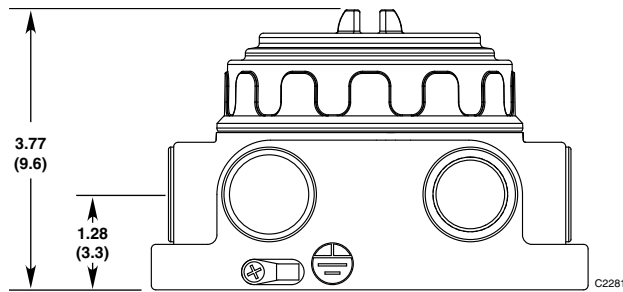
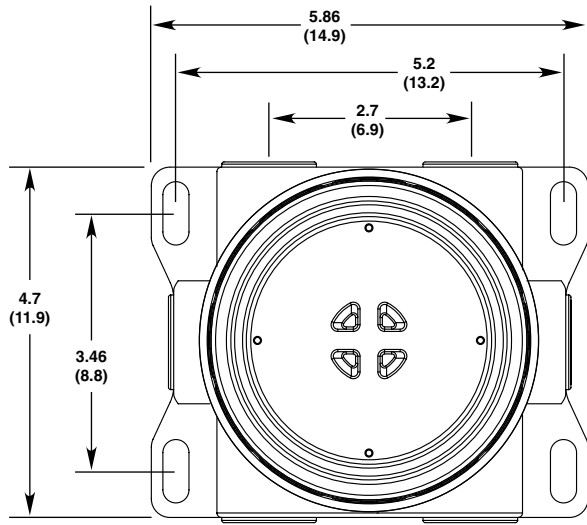

Figure 11—Dimensions of Model STB Termination Box in Inches (Centimeters)

CERTIFICATION—

For complete approval details, refer to the appropriate appendix:



- Appendix A – FM
- Appendix B – CSA
- Appendix C – ATEX
- Appendix D – IECEx
- Appendix E – INMETRO

SIL Approval - IEC 61508
Certified SIL 2 Capable.

For specific information regarding SIL safety certification, refer to the Model UD10 Safety Reference Manual, number 95-8668,.

Table 6—Gas Detectors Compatible with the UD10

| Device | Toxic ¹ | Catalytic Combustible | IR Combustible ² | Ultrasonic Acoustic | Instruction Manual |
|--------------------------|--------------------|-----------------------|-----------------------------|---------------------|------------------------------------|
| GT3000 | X | | | | 95-8616 |
| PIR9400 | | | X | | 95-8440 |
| PIRDUCT | | | X | | 95-8573 |
| PIRECL | | | X | | 95-8526 |
| PIRECL-CO ₂ * | X | | | | 95-8676 |
| OPECL | | | X | | 95-8556 |
| CGS | | X | | | 90-1041 |
| 505/CGS | | X | | | 95-8472 |
| C706X ³ | X | | | | 95-8396, 95-8411, 95-8414, 95-8439 |
| NTMOS** | X | | | | 95-8604 |
| AC100/ATX10 | | | | X | 95-8657 |
| LS2000 | | | X | | 95-8714 |

1 Hydrogen sulfide, Ammonia, Chlorine, Hydrogen, Oxygen, Carbon Monoxide, and Sulfur Dioxide.

2 Hydrocarbons, see device manual for details.

3 **C7065E Oxygen detector is not supported.**

* Carbon dioxide only.

** Hydrogen sulfide only.

DEVICE REPAIR AND RETURN

Prior to returning devices, contact the nearest local Detector Electronics office so that a Return Material Identification (RMI) number can be assigned. **A written statement describing the malfunction must accompany the returned device or component to assist and expedite finding the root cause of the failure.**

Pack the unit properly. Always use sufficient packing material. Where applicable, use an antistatic bag as protection from electrostatic discharge. The RMI number should be clearly marked on the outside of the box.

NOTE

Inadequate packaging that ultimately causes damage to the returned device during shipment will result in a service charge to repair the damage incurred during shipment.

Return all equipment transportation prepaid to the factory in Minneapolis.

NOTE

It is highly recommended that a spare be kept on hand for field replacement to ensure continuous protection.

ORDERING INFORMATION

Sensor module, transmitter module and termination boxes (if used) must be ordered separately.

Refer to the UD10 Model Matrix for ordering details.

ACCESSORIES

| Part Number | Description |
|-------------|--------------------------------------|
| 009700-001 | Magnetic Tool |
| 103922-001 | 475 Field Communicator |
| 010268-001 | Gas Inspector CD |
| 010204-001 | W6300G1003 Gas Inspector Connector |
| 005003-001 | Lubriplate grease, 1 oz. |
| 101197-001* | Stop Plug, 3/4" NPT, AL |
| 101197-004* | Stop Plug, 3/4" NPT, SS |
| 101197-005 | Stop Plug, M25, AL, IP66 |
| 101197-003 | Stop Plug, M25, SS, IP66 |
| 010816-001 | Stop Plug, 20PK, 3/4" NPT, AL |
| 010817-001 | Stop Plug, 20PK, 3/4" NPT, SS |
| 010818-001 | Stop Plug, 20PK, M25, AL, IP66, EXDE |
| 010819-001 | Stop Plug, 20PK, M25, SS, IP66, EXDE |
| 104190-001 | Stop Plug, M25, AL, INMETRO |
| 104190-002 | Stop Plug, 3/4" NPT, AL, INMETRO |
| 104190-003 | Stop Plug, M25, SS, INMETRO |
| 104190-004 | Stop Plug, 3/4" NPT, SS, INMETRO |
| 102804-001 | Reducer, M25 to M20, AL |
| 102804-003 | Reducer, M25 to M20, SS |

*NEMA/Type 4X, IP66 rating requires addition of Teflon tape.

REPLACEMENT PARTS

| Part Number | Description |
|-------------|------------------------------------|
| 010569-001 | Electronics Module - Relay/4-20 mA |

UD10 MODEL MATRIX

| MODEL | DESCRIPTION | |
|---------|-----------------------------|-----------------------------|
| UD10 | Universal Display Unit | |
| | TYPE | MATERIAL |
| | A | Aluminum |
| | S | Stainless Steel (316) |
| | TYPE | THREAD TYPE |
| | 5E | 5 Port, 1/2" NPT |
| | 5F | 5 Port, Metric M20 |
| | 5M | 5 Port, Metric M25 |
| | 5N | 5 Port, 3/4" NPT |
| | TYPE | OUTPUTS |
| | 25 | Relay, 4-20 mA, RS485, HART |
| | 28 | EQP / DCU Emulator |
| | TYPE | APPROVALS* |
| | B | INMETRO (Brazil) |
| | R | VNIIFTRI (Russia) |
| | S | SIL |
| | T | SIL/FM/CSA/ATEX/CE/IECEX |
| W | FM/CSA/ATEX/CE/IECEX | |
| TYPE | CLASSIFICATION (Div/Zone) | |
| 2 | Ex d (Flameproof) | |
| TYPE | OPTIONAL CONDITIONING BOARD | |
| (Blank) | None | |
| C | CGS | |
| N | NTMOS** | |

* Type Approvals can use one or more letters to designate the approvals of the product.

** Not required for DCU Emulator model.

APPENDIX A

FM APPROVAL DESCRIPTION

Class I, Div. 1, Groups B, C & D (T4);
Class I, Div. 2, Groups B, C & D (T4);
Class I, Zone 1/2 AEx d IIC (T5);
Class II/III, Div. 1/2, Groups E, F & G.
Tamb –50°C to +75°C
NEMA/Type 4X, IP66
Conduit seal not required.

Performance verified in accordance with:
FM 6320:2014, FM 6325: 2005, ANSI/
ISA-92.0.01:1998, ANSI/ISA-92.00.01:2010, ANSI/
ISA 60079-29-1 (12.13.01): 2013.

This approval does not include or imply approval of gas detector heads or other apparatus to which the subject instrument may be connected. In order to maintain a Factory Mutual Research approved system, the measurement input signal to which this instrument is connected must also be approved by Factory Mutual Research.

UD10 hazardous location and performance testing was successfully completed down to –55°C. However, the FM approved rating is limited to –50°C as there are no conduit fittings, cables, or cable glands that are presently listed for use below –50°C in the US. FM approvals policy does not allow product temperature ratings to exceed required installation components (such as conduit seals). The user must ensure that conduit fittings, cables, cable glands, etc., are rated for the expected minimum ambient temperature of the installation.

NOTE

Consideration must be given to overall Gas System Performance Requirements.

WARNING

When a sensor/detector is connected directly to the UD10 housing, the lower ratings of the two devices will prevail.

APPENDIX B

CSA CERTIFICATION DESCRIPTION

CSA 2029512.
Class I, Div. 1, Groups B, C & D (T5);
Class I, Div. 2, Groups B, C & D (T4);
Class II/III, Div. 1/2, Groups E, F & G.
(Tamb = -55°C to +75°C)
Type 4X
Conduit seal not required.

Performance verified in accordance with:
CSA C22.2 #152.

NOTE

Consideration must be given to overall Gas System Performance Requirements.

WARNING

When a sensor/detector is connected directly to the UD10 housing, the lower ratings of the two devices will prevail.

APPENDIX C

ATEX APPROVAL DESCRIPTION

Ex d IIC Gb T6
Ta = -55°C to +75°C IP66
(without integral CGS)

Ex d IIC Gb T5
Ta = -40°C to +75°C IP66
(with integral CGS or LON)

Performance verified in accordance with:
EN 60079-29-1:2007
EN 60079-29-4:2010

Compliance with:

EN 60079-0:2012+A11:2013
EN 60079-1:2014

Special Conditions for Safe Use ('X'):

The UD10 control unit complies with EN 60079-29-1 and EN 60079-29-4 only when connected to a Detector Head that also has been evaluated to EN 60079-29-1 and EN 60079-29-4.

Flameproof joints are not user serviceable, contact Det-Tronics.

UD10 hazardous location and performance testing was successfully completed down to -55°C. However, the FM approved rating is limited to -50°C as there are no conduit fittings, cables, or cable glands that are presently listed for use below -50°C in the US. FM approvals policy does not allow product temperature ratings to exceed required installation components (such as conduit seals). The user must ensure that conduit fittings, cables, cable glands, etc., are rated for the expected minimum ambient temperature of the installation.

NOTE

Consideration must be given to overall Gas System Performance Requirements.

WARNING

When a sensor/detector is connected directly to the UD10 housing, the lower ratings of the two devices will prevail.

CATALYTIC COMBUSTIBLE GAS SENSOR (CGS)

CE 0539 II 2 G

Ex db IIC T3, T5 Gb EN60079-29-1

DEMKO 02 ATEX 131323X

T5 (Tamb = -40°C to +75°C)

T3 (Tamb = -55°C to +125°C).

EN Standards: EN 60079-0: 2012+A11: 2013

EN 60079-1: 2014

EN 60079-29 -1: 2007

Special Conditions for Safe Use of CGS:

The CGS Combustible Gas Sensor is certified for use in following ambient temperatures:

- ambient temperature range -40°C to +75°C.

Coding: **Ex db IIC T5 Gb**

- ambient temperature range -55°C to +125°C.

Coding: **Ex db IIC T3 Gb**

The actual temperature range is marked on the sensor.

The performance ambient temperature rating is limited to -40°C to +75°C.

The CGS Combustible Gas Sensor can withstand repeated exposures to 125°C for periods up to 12 hours. It is recommended that the sensor be replaced after maximum 500 hours of exposed to the 125°C temperature condition.

The CGS Combustible Gas Sensor must be used in conjunction with the before mentioned ATEX certified Detector Electronics Corp. combustible gas detector control units for compliance with EN 60079-29-1 standards.

The CGS Combustible Gas Sensor must only be mounted into the enclosures of the Infiniti Gas Transmitter Model U9500A Series, the Combustible Gas Transmitter Model 505 Series, the Digital Communication Unit EQ 22xDCUEx Series or the Sensor Termination Box Model STB Series.

The actual enclosure must provide a maximum measured reference pressure of 15 bar measured according to EN 60079-1: 2014, §15.

The CGS Combustible Gas Sensor is to be installed in places where there is a low risk of mechanical damage. Flameproof joints are not user serviceable; contact Det-Tronics Service.

APPENDIX D

IECEX APPROVAL DESCRIPTION

Ex d IIC Gb T6
Ta = -55°C to +75°C IP66
(without integral CGS)

Ex d IIC Gb T5
Ta = -40°C to +75°C IP66
(with integral CGS or LON)

Performance verified in accordance with:
IEC 60079-29-1:2007
IEC 60079-29-4: 2009

Compliance with:

IEC 60079-0:2011-06
IEC 60079-1:2014-06

Special Conditions for Safe Use ('X'):

The UD10 control unit complies with IEC 60079-29-1 when connected to a Detector Head with an IEC certificate of conformity to IEC 60079-29-1.

Flameproof joints are not user serviceable, contact Det-Tronics.

UD10 hazardous location and performance testing was successfully completed down to -55°C. However, the FM approved rating is limited to -50°C as there are no conduit fittings, cables, or cable glands that are presently listed for use below -50°C in the US. FM approvals policy does not allow product temperature ratings to exceed required installation components (such as conduit seals). The user must ensure that conduit fittings, cables, cable glands, etc., are rated for the expected minimum ambient temperature of the installation.

NOTE

Consideration must be given to overall Gas System Performance Requirements.



WARNING

When a sensor/detector is connected directly to the UD10 housing, the lower ratings of the two devices will prevail.

Special Conditions of Safe Use of CGS:

The CGS Combustible Gas Sensor is to be installed in places where there is a low risk of mechanical damage.

The CGS Combustible Gas Sensor is certified for use in following ambient temperatures:

Ambient temperature range -40°C to +75°C, Coding: Ex db IIC T5

Ambient temperature range -55°C to +125°C, Coding: Ex db IIC T3

The actual temperature range is marked on the sensor.

The CGS Combustible Gas Sensor has an ambient temperature rating for performance of -40°C to +75°C

The CGS Combustible Gas Sensor can withstand repeated exposures to 125°C for periods up to 12 hours. It is recommended that the sensor be replaced after maximum 500 hours of exposure to the 125°C temperature condition.

The CGS Combustible Gas Sensor must only be mounted into the enclosures of the Infiniti Gas Transmitter Model U9500A Series, the Combustible Gas Transmitter Model 505 Series, the Digital Communication Unit EQ 22xxDCUEX Series or the Sensor Termination Box Model STB Series.

The actual enclosure must provide a maximum measured reference pressure of 15 bar measured according to IEC 60079-1:2014, § 15.

Flameproof joints are not user serviceable; contact Det-Tronics Service.

APPENDIX E

ADDITIONAL APPROVALS

INMETRO (Brazil)

UL-BR 15.0469X
Ex d IIC T5 Gb IP66
T5 (Tamb –40°C to +75°C) With integral CGS
– OR –

Ex d IIC T6 Gb IP66
T6 (Tamb –55°C to +75°C) Without integral CGS

All cable entry devices shall be Brazil certified in the type of explosion protection, flameproof enclosure “d,” suitable for the conditions of use and correctly installed, with an ingress protection rating of IP66.

A screw or cover lock is provided for a secondary means of fastening the cover.

Specific Conditions of Use for Ex Equipment or Schedule of Limitations for Ex Components:

The UD10 with integral CGS (Combustible Gas Sensor) is to be installed in place where there is a low risk of mechanical damage.

The CGS Combustible Gas Sensor must be mounted into the enclosure of the Infiniti Gas Transmitter Model U9500A Series, the Combustible Gas Transmitter Model 505 Series, the Digital Communication Unit EQ22xxDCUEX Series or the Sensor Termination Box Model STB Series.

APPENDIX F

USING A HANDHELD HART DEVICE CONNECTED TO THE UD10'S 4-20 MA OUTPUT (UD10 WITH ANY DETECTOR)

NOTE

Refer to the front of this manual for complete information regarding installation, wiring, and startup of the UD10.

WIRING

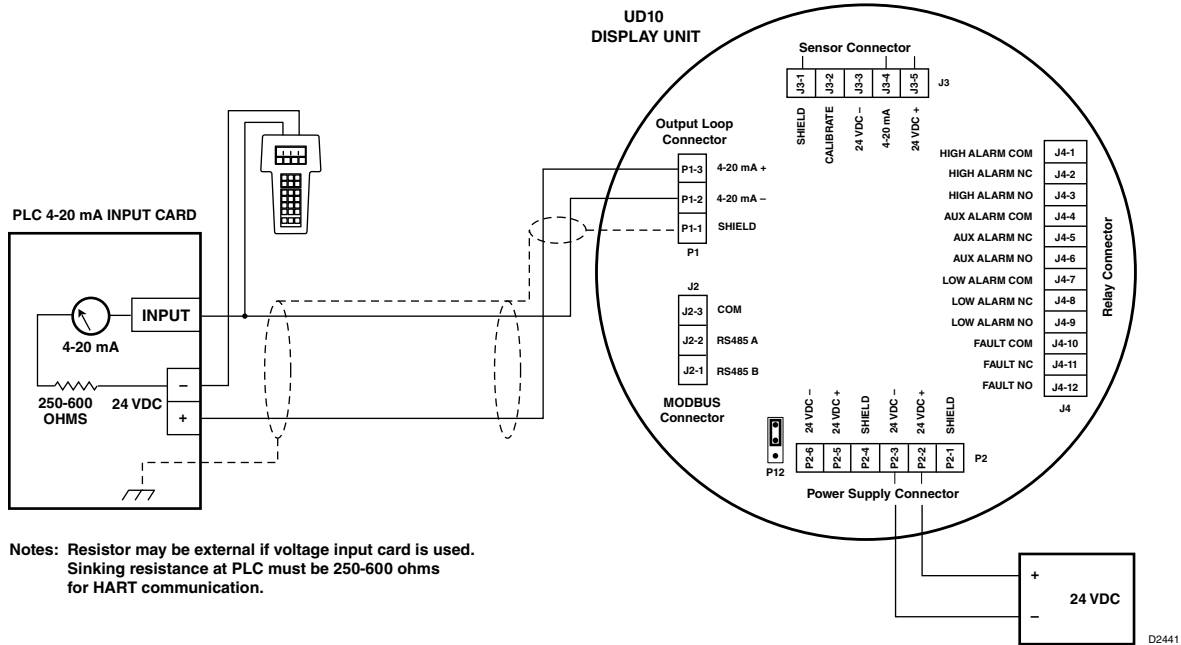

HART Handheld Communicator Connected to the UD10's 4-20 mA Output

IMPORTANT

To ensure proper operation of the HART communication system, a power supply with low noise and ripple must be used. If noise or ripple on the main power source could interfere with the HART function, an isolated power source is recommended. For additional information, refer to "Power Supply Requirements" in the "Wiring" section of this manual.

MENU STRUCTURE

Refer to the following menu tree when using a HART handheld communicator, connected to the UD10's 4-20 mA output.

MENU HELP

Status menus only allow the user to view the data.
The Setup menus allow the user to both view and edit the data.

Display Variables

| | |
|--------------------------------|--------|
| 1) Gas Name | xxxxx |
| 2) Gas Value | xxxx.x |
| 3) High Alarm | T/F |
| 4) Low Alarm | T/F |
| 5) AUX Alarm | T/F |
| 6) Analog Output | xxxxx |
| 7) Upper Range Value | xxxxx |
| 8) Lower Range Value | xxxxx |
| 9) Fault | T/F |
| SV Value | xxxxx |
| TV Value | xxxxx |
| QV Value | xxxxx |
| Process Variable (strip chart) | |

- Diagnostics**
- 1) Display Status Menu →
 - 2) Device Status Menu →
 - 3) Display Test Menu →

- UD10**
- 1) Display Variables →
 - 2) Diagnostics →
 - 3) Device Setup →

- Display Status Menu**
- 1) Display General Info
 - 2) Display History
 - 3) Display Info
 - 4) Display Fault/Status Info

- Device Status Menu**
- 1) Device Info
 - 2) Device Info 2
 - 3) Sensor Info
 - 4) Device History Info
 - 5) Device Fault/Status

- Display Test Menu**
- 1) Response Test
 - 2) Loop Test
 - 3) D/A Trim
 - 4) Self Test
 - 5) Reset

- Loop Test**
- 1) 4 mA
 - 2) 20 mA
 - 3) Other
 - 4) End

- Display Setup**
- 1) Alarm Setting
 - 2) Write Protect
 - 3) Display HART Option
 - 4) Display RTC

- Device Setup**
- 1) Display setup →
 - 2) Device Setup →
 - 3) Device Cal →

- Device Setup**
- 1) Device HART Option

- Device Cal**
- 1) Sensor Calibration

Alarm Setting

| | |
|--------------------------|-------|
| 1) Reset Latched Alarms | |
| 2) High Alarm Level | xx.xx |
| 3) High Alarm Latch | Y/N |
| 4) High Alarm NE/NDE | → |
| 5) Low Alarm Level | xx.xx |
| 6) Low Alarm Latch | Y/N |
| 7) Low Alarm NE/NDE | → |
| 8) Auxiliary Alarm Level | xx.xx |
| 9) Aux Alarm Latch | Y/N |
| Aux Alarm NE/NDE | → |

- Write Protect**
- 1) Change Mode →
 - 2) Write Protect Y/N

Display HART Option

| | |
|-----------------------|-------|
| 1) Tag | xxxxx |
| 2) Descriptor | xxxxx |
| 3) Long Tag | xxxxx |
| 4) Message | xxxxx |
| 5) Date | xxxxx |
| 6) Final assembly num | xxxxx |

Display RTC

| | |
|------------|-----|
| 1) Seconds | xx |
| 2) Minutes | xx |
| 3) Hours | xx |
| 4) Day | xx |
| 5) Month | xxx |
| 6) Year | xx |

Device HART Option

| | |
|-----------------------|-------|
| 1) Tag | xxxxx |
| 2) Descriptor | xxxxx |
| 3) Message | xxxxx |
| 4) Final assembly num | xxxxx |

- Calibration**
- 1) Execute
 - 2) Abort

Device Info

| | |
|--------------------|-------|
| 1) Manufacturer | xxxxx |
| 2) Tag | xxxxx |
| 3) Descriptor | xxxxx |
| 4) Message | xxxxx |
| 5) Final Asmby Num | xxxxx |
| 6) Dev ID | xxxxx |
| 7) Write Protect | xxxxx |
| 8) Model | xxxxx |

Device Info 2

| | |
|----------------------|-------|
| 1) Serial Number | xxxxx |
| 2) Hardware Revision | |
| 3) Firmware Revision | |
| 4) Universal Rev | xxxxx |
| 5) Flid Dev Rev | xxxxx |
| 6) Software Rev | xxxxx |

Sensor Info

| | |
|----------------------|-------|
| 1) Sensitivity | xxxxx |
| 2) Gas Name | xxxxx |
| 3) Revision | xxxxx |
| 4) PV USL | xxxxx |
| 5) PV LSL | xxxxx |
| 6) Hours | xxxxx |
| 7) Serial Number | xxxxx |
| 8) Hardware Revision | xxxxx |
| 9) Firmware Revision | xxxxx |
| Cal Point Zero | xxxxx |
| Cal Point Span | xxxxx |

- Device History Info**
- 1) Calibration Log

Calibration Log

| | |
|-------------------------------|--|
| xxxxxxx | |
| Date: dd-mmm-yy Time:hh:mm:ss | |
| ----- | |
| First | |
| Previous | |
| Next | |
| End | |

Device Fault/Status

| | |
|--------------------------|-------|
| 1) Operating Mode | xxxxx |
| 2) Calibration State | xxxxx |
| 3) Status 1 | → |
| 4) Status 2 | → |
| 5) Fault 1 | → |
| 6) Fault 2 | → |
| 7) Fault 3 | → |
| 8) Fault 4 | → |
| 9) Extended Fault/Status | → |

- Status 1**
- 1) Device status 1 xxxxx

Device Status 1

| | |
|----------------------|--------|
| Calibration Active | ON/OFF |
| Warm Up | ON/OFF |
| Low Alarm | ON/OFF |
| Aux Alarm | ON/OFF |
| High Alarm | ON/OFF |
| Self Test | ON/OFF |
| Configuration Change | ON/OFF |
| Alignment Mode | ON/OFF |

- Status 2**
- 1) Device status 2 xxxxx

Device Status 2

| | |
|--------------------|--------|
| Write Protect | ON/OFF |
| Response Test | ON/OFF |
| 4-20 Fixed | ON/OFF |
| Sensor Removed | ON/OFF |
| Sensor End Of Life | ON/OFF |
| Loop Test Active | ON/OFF |
| TDSA Alarm | ON/OFF |
| Quick Alarm | ON/OFF |

- Fault 1**
- 1) Device Fault 1 xxxxx

Device Fault 1

| | |
|--------------------------|--------|
| Loop Fault | ON/OFF |
| Supply Voltage Fault | ON/OFF |
| Calibration Fault | ON/OFF |
| Memory Fault | ON/OFF |
| ADC Fault | ON/OFF |
| Internal Voltage Fault | ON/OFF |
| Zero Drift | ON/OFF |
| Temperature Sensor Fault | ON/OFF |

- Fault 2**
- 1) Device Fault 2 xxxxx

Device Fault 2

| | |
|---------------------|--------|
| Wrong Sensor Type | ON/OFF |
| Lamp Fault | ON/OFF |
| Alignment Fault | ON/OFF |
| Blocked Optic Fault | ON/OFF |
| Cal Line Active | ON/OFF |
| Sensor Fault | ON/OFF |
| Noise Fault | ON/OFF |
| Align ADC Fault | ON/OFF |

- Fault 3**
- 1) Device Fault 3 xxxxx

Device Fault 3

| | |
|-------------------|--------|
| Align Fault | ON/OFF |
| Align Warning | ON/OFF |
| DAC Fault | ON/OFF |
| High Fault | ON/OFF |
| Low Fault | ON/OFF |
| Device Warm Up | ON/OFF |
| Ref Channel Fault | ON/OFF |
| Act Channel Fault | ON/OFF |

- Fault 4**
- 1) Device Fault 4 xxxxx

Device Fault 4

| | |
|-------------------------|--------|
| Incompatible Version | ON/OFF |
| Detection Disable Fault | ON/OFF |
| Oi Fault | ON/OFF |
| Diminished Detect Fault | ON/OFF |
| Communication Fault | ON/OFF |
| Reserved | ON/OFF |
| Reserved | ON/OFF |
| General Fault | ON/OFF |

Extended Fault/Status

| | |
|-----------------|----|
| Extended Byte 0 | xx |
| Extended Byte 1 | xx |
| Extended Byte 2 | xx |
| Extended Byte 3 | xx |
| Extended Byte 4 | xx |
| Extended Byte 5 | xx |
| Extended Byte 6 | xx |
| Extended Byte 7 | xx |

Display General Info

| | |
|--------------------|-------|
| 1) Manufacturer | → |
| 2) Tag | xxxxx |
| 3) Long Tag | xxxxx |
| 4) Descriptor | xxxxx |
| 5) Message | xxxxx |
| 6) Final Asmby Num | xxxxx |
| 7) Dev ID | xxxxx |
| 8) Write Protect | xxxxx |
| 9) Model | xxxxx |

DET-TRONICS

- Display History**
- 1) History
 - 2) Event Log

History

| | |
|------------------|---------|
| 1) Running Hrs | xxxx |
| 2) Max Temp | xx.xx C |
| 3) Max Temp Time | |
| 4) Min Temp | xx.xx C |
| 5) Min Temp Time | |

Date : DD/MM/YY
Time: HR.MM:SS

- Event Log**
- 1) Event Log

Event Log

| | |
|----------------|----------------|
| XXXX | |
| Date: dd-mm-yy | Time: hh:mm:ss |
| ----- | |
| First | |
| Previous | |
| Next | |
| End | |

- Display Info**
- 1) Display RTC
 - 2) Serial Number xxxxx
 - 3) Hardware Rev xxxxx
 - 4) Firmware Revision
 - 5) Universal Rev xxxxx
 - 6) Flid Dev Rev xxxxx
 - 7) Software Rev xxxxx
 - 8) DD Build Version

Display RTC

| | |
|------------|-----|
| 1) Seconds | xx |
| 2) Minutes | xx |
| 3) Hours | xx |
| 4) Day | xx |
| 5) Month | xxx |
| 6) Year | xx |

- Display Fault/Status Info**
- 1) Status 1 xxxxx
 - 2) Status 2 xxxxx
 - 3) Fault 1 xxxxx
 - 4) Fault 2 xxxxx

Display Status 1

| | |
|------------------|--------|
| Reserved | ON/OFF |
| Reserved | ON/OFF |
| HART Test | ON/OFF |
| LON Attached | ON/OFF |
| Response Test | ON/OFF |
| Manual Self Test | ON/OFF |
| Input HART | ON/OFF |
| Reserved | ON/OFF |

Display Status 2

| | |
|------------------|--------|
| Any Fault | ON/OFF |
| CAL Active | ON/OFF |
| Warm up Mode | ON/OFF |
| Low Relay Active | ON/OFF |
| Hi Relay Active | ON/OFF |
| Aux Relay Active | ON/OFF |
| Current Fixed | ON/OFF |
| MB Write Protect | ON/OFF |

Display Fault 1

| | |
|-------------------|--------|
| 12V Fault | ON/OFF |
| 5V Fault | ON/OFF |
| Reserved | ON/OFF |
| 1.25V Fault | ON/OFF |
| Output Loop Fault | ON/OFF |
| Input Loop Fault | ON/OFF |
| 0V Fault | ON/OFF |
| ADC Fault | ON/OFF |

Display Fault 2

| | |
|-----------------------|--------|
| Low CAL Line Fault | ON/OFF |
| Reserved | ON/OFF |
| FRAM Fault | ON/OFF |
| ADC Diagnostics Fault | ON/OFF |
| 24V Fault | ON/OFF |
| Flash Fault | ON/OFF |
| RAM Fault | ON/OFF |
| WDT Fault | ON/OFF |

Extended Byte 3

| | |
|--------------|--------|
| Pre-Alarm | ON/OFF |
| Fire Alarm | ON/OFF |
| UV Pre-Alarm | ON/OFF |
| IR Pre-Alarm | ON/OFF |
| UV Alarm | ON/OFF |
| IR Alarm | ON/OFF |
| Misc Alarm | ON/OFF |
| Reserved | ON/OFF |

Extended Byte 7

| | |
|---------------------|--------|
| X Fault | ON/OFF |
| Oi Fault | ON/OFF |
| Oi Pre-Fault | ON/OFF |
| High IR1 Fault | ON/OFF |
| High IR2 Fault | ON/OFF |
| Short Circuit Fault | ON/OFF |
| Power Fault | ON/OFF |
| Reserved | ON/OFF |

APPENDIX G

UD10 with GT3000 TOXIC GAS DETECTOR

NOTE

For complete information regarding the GT3000 Gas Detector, refer to instruction manual 95-8616.

WIRING

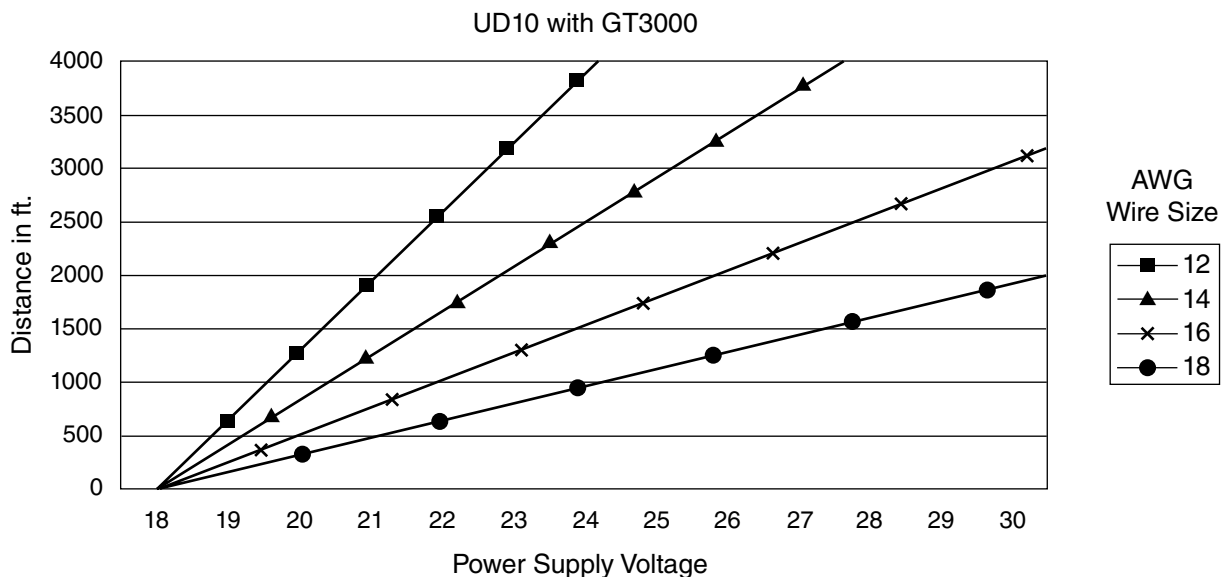

Notes: Maximum recommended cable length from power source to UD10 is 2000 feet.
Maximum recommended cable length from UD10 to sensor/STB termination box is 2000 feet.

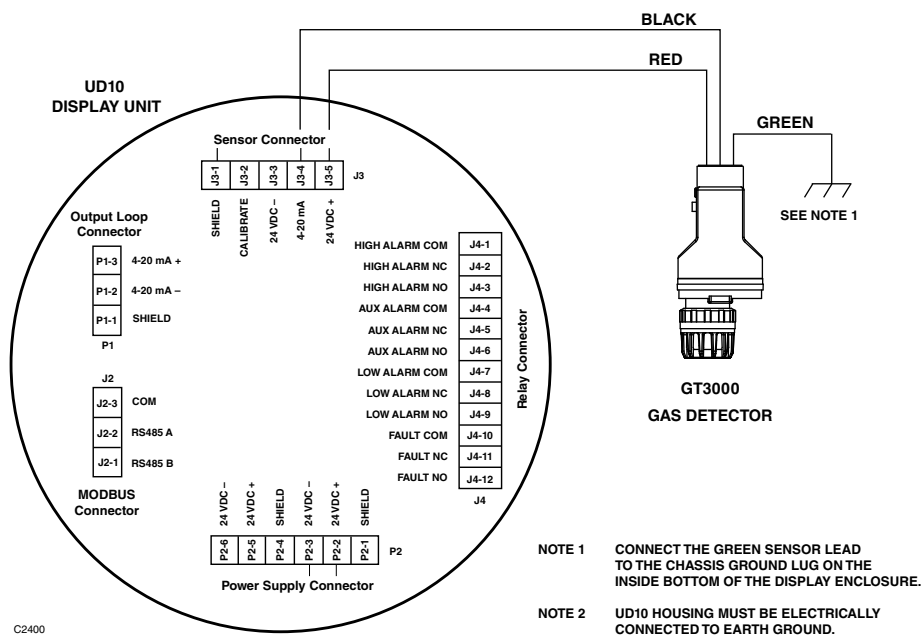

GT3000 Detector Wired Directly to UD10

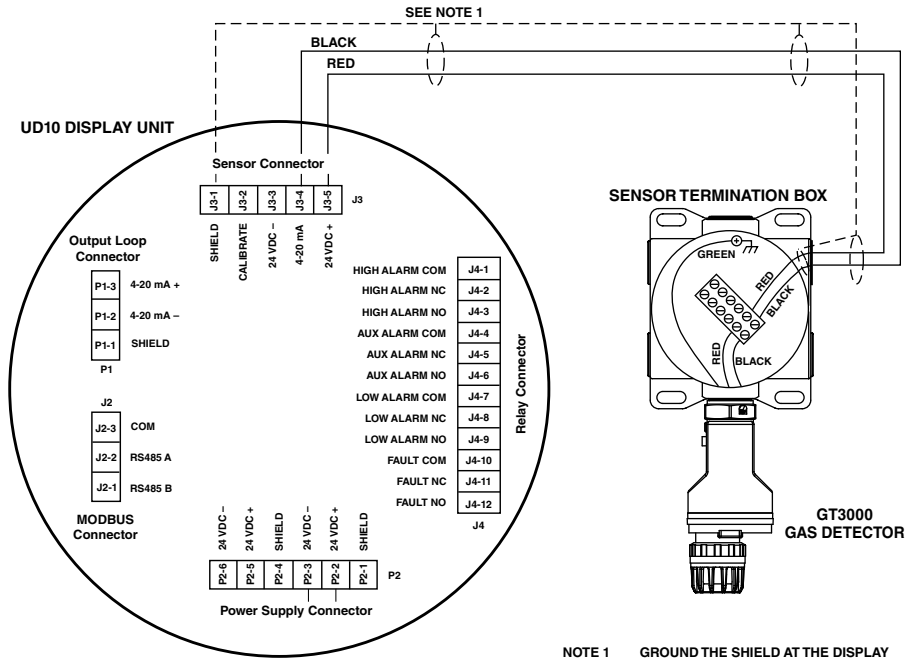

C2401

UD10 Wired to GT3000 Detector with Sensor Termination Box

ORIENTATION

The device must be mounted in a vertical position only, with the GT3000 pointing down.



LIVE MAINTENANCE

NOTE

The sensor module on the GT3000 Gas Detector can be hot swapped, i.e., replaced without removing power or de-classifying the area. To replace a GTX Transmitter connected to the UD10 with a new transmitter or a different detector type, the area **must** be de-classified.

NOTE

Removing the sensor module with power applied will result in a fault condition until a new sensor module of the same type is installed. When replacing an oxygen sensor, this action will also result in an alarm condition as the decreasing 4-20 mA signal passes through the alarm range. Inhibit response devices to prevent unwanted actuation.

For complete information regarding sensor replacement with the GT3000 Gas Detector, refer to the GT3000 instruction manual, number 95-8616.

CALIBRATION

GT3000 WITH TOXIC GAS SENSOR

From GT3000:

- Using the magnet, activate the magnetic calibration switch on the GT3000. The green LED turns to yellow.

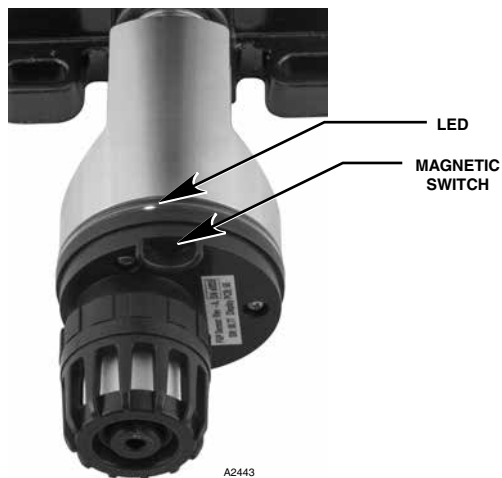

Location of Magnetic Switch on GT3000

- The UD10 will display “Waiting for Zero” on the main display screen, with the yellow LED on the detector housing illuminated continuously.
- The UD10 will then display “Waiting for Signal” on the screen, while the yellow LED on the detector is flashing. The device automatically performs the zero calibration.
- The UD10 will display “Waiting for Gas” on the screen, while the yellow LED on the detector is flashing.
- Apply calibration gas to the sensor.
- The UD10 will display “Waiting for Span” on the screen, while the yellow LED on the detector is flashing.
- When the UD10 displays “Remove Cal Gas” on the screen and all LEDs on the detector housing are off, remove the calibration gas.
- After successful calibration, the UD10 automatically returns to the normal display with the green LED illuminated on the detector.

From UD10

- Using the magnet to activate the switches on the UD10 display, navigate to the Calibration menu.

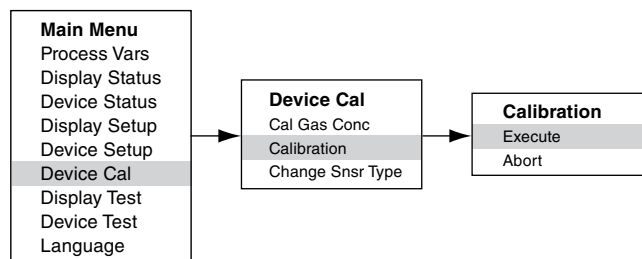

- Activate “Execute” (Enter/Select) to start calibration.
- The UD10 will display “Waiting for Zero” on the main display screen, with the yellow LED on the detector housing illuminated continuously. The device automatically performs the zero calibration.
- The UD10 will then display “Waiting for Gas” on the screen, while the yellow LED on the detector is flashing.
- Apply calibration gas to the sensor.
- The UD10 will display “Waiting for Span” on the screen, while the yellow LED on the detector is flashing.
- When the UD10 displays “Remove Cal Gas” on the screen and the LEDs on the detector housing are off, remove the calibration gas.
- After completion of a successful calibration, the UD10 automatically returns to the normal mode with the green LED illuminated on the detector.

| UD10 mA Output During Calibration (UD10 with GT3000) | | |
|---|---------------|----------------|
| UD10 Display Reading | Standard Mode | Replicate Mode |
| Waiting for Zero | 3.8 | 3.8 |
| Waiting for Gas | 3.8 | 3.8 |
| Waiting for Span | 3.8 | 3.8 |
| Remove Cal Gas | 3.8 | 3.8 |
| Back to Normal | 4.0 | 4.0 |

GT3000 WITH OXYGEN SENSOR

From GT3000:

1. Using the magnet, activate the magnetic calibration switch on the GT3000. The green LED turns to yellow.
2. The device automatically performs the zero calibration. The yellow LED on the GT3000 is on continuously. The UD10 displays "Waiting for Zero" on the main display screen.
3. When the yellow LED on the GT3000 flashes, the device automatically performs the span calculation. If using bottled 20.9% oxygen, apply immediately. The UD10 displays "Waiting for Span" on the screen.
4. After successful calibration, the green LED on the GT3000 is on continuously and the UD10 automatically returns to the normal display. Remove calibration gas (if used).

From UD10

1. Using the magnet to activate the switches on the UD10 display, navigate to the "Calibration" menu.

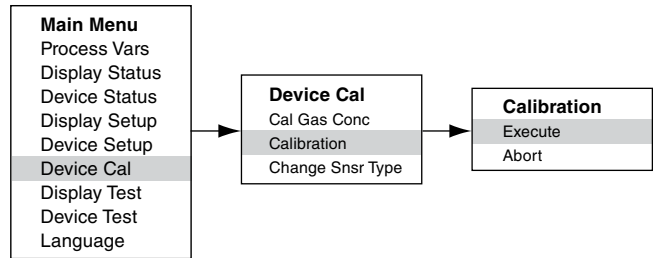

2. Activate "Execute" (Enter/Select) to start calibration.
3. The UD10 will display "Waiting for Zero" on the main display screen, with the yellow LED on the detector housing illuminated continuously. The device automatically performs the zero calibration.
4. When the UD10 displays "Waiting for Span" on the screen and the yellow LED on the detector is flashing, the device automatically performs the span calculation. If using bottled 20.9% oxygen, apply immediately.
5. After completion of a successful calibration, the UD10 automatically returns to the normal mode with the green LED illuminated on the detector. Remove calibration gas (if used).

MENU STRUCTURE

UD10 with GT3000 Detector

Refer to the following menu when using the UD10's LCD display and internal magnetic switches.

When connecting a HART Communicator to the UD10's 4-20 mA output, refer to the "UD10 HART Handheld" menu in Appendix F.

MENU HELP

*Status menus only allow the user to view the data.
The Setup menus allow the user to both view and edit the data.*

MAIN MENU
PROCESS VARS →
DISPLAY STATUS →
DEVICE STATUS →
DISPLAY SETUP →
DEVICE SETUP →
DEVICE CAL →
DISPLAY TEST →
DEVICE TEST →
LANGUAGE →

PROCESS VARS
GAS NAME XXXXX
GAS VALUE X.XX
HIGH ALARM Y/N
LOW ALARM Y/N
AUX ALARM Y/N
ANALOG INPUT X.XX MA
ANALOG OUTPUT X.XX MA
URV X.XX
LRV X.XX
FAULT Y/N

DISPLAY STATUS
GENERAL INFO →
FAULT/STATUS →
HISTORY →
DISPLAY INFO →
RS485 →
DEBUG MENU →

DEVICE STATUS
GENERAL INFO →
FAULT/STATUS →
TX INFO →
SENSOR INFO →
HISTORY →
DEBUG MENU →

DISPLAY SETUP
ALARM SETTING →
MODE SELECT →
HART OPTION →
RTC →
RS485 →
INPUT LOOP CAL →
CONTRAST CONTRL →
OUTPUT MODE →
BACKLIGHT CTRL →
HEATER CTRL →
WRITE PROTECT →
OP FEEDBACK FLT →
SCROLLING DISPLAY →
SET SCROLLING RATE XXX%

DEVICE SETUP
DEVICE OPTION →
HART OPTION →
RTC →
WRITE PROTECT →

DEVICE CAL
CAL GAS CONC XX.XX
CALIBRATION →
CHANGE SNSR TYPE →

DISPLAY TEST
SELF TEST →
RESPONSE TEST →
LOOP TEST →
D/A TRIM →

DEVICE TEST
SELF TEST →
RESPONSE TEST →
LOOP TEST →
D/A TRIM →

LANGUAGE
ENGLISH
SECOND LANGUAGE

ALARM SETTING
RST LATCH ALARMS
HIGH ALARM LEVEL XX.XX
HIGH ALARM LATCH Y/N
HIGH ALARM NE/ND →
LOW ALARM LEVEL XX.XX
LOW ALARM LATCH Y/N
LOW ALARM NE/ND →
AUX ALARM LEVEL XX.XX
AUX ALARM LATCH Y/N
AUX ALARM NE/ND →

HIGH ALARM NE/ND
NE-NORMALY ENERGIZED
NDE-NORMALY DEENERGIZED

LOW ALARM NE/ND
NE-NORMALY ENERGIZED
NDE-NORMALY DEENERGIZED

AUX ALARM NE/ND
NE-NORMALY ENERGIZED
NDE-NORMALY DEENERGIZED

MODE SELECT
HART DEVICE
PIR9400
PIRDUCT
C706X
505
NTMOS
CGS
GENERIC DEVICE

DEVICE OPTION
GAS NAME XXXX
UNIT OF MEASURE →
URV XXXX
LRV XXXX
USL XXXX
LSL XXXX

HART OPTION
TAG XXXXX
LONG TAG XXXXX
DESCRIPTOR XXXXX
DATE XXXXX
MESSAGE XXXXX
FINAL ASSY NUM XXXXX

HART OPTION
TAG XXXXX
DESCRIPTOR XXXXX
DATE DD/MM/YYYY
MESSAGE XXXX
FINAL ASSY NUM XXXX

RTC
DISPLAYED Y/N
SECONDS XX
MINUTES XX
HOURS XX
DAY XX
MONTH XX
YEAR XX

RTC
SYNC W/DISP XX
SECONDS XX
MINUTES XX
HOURS XX
DAY XX
MONTH XX
YEAR XX

RS485
BAUD RATE →
PARITY →
POLL ADDRESS XXXX

WRITE PROTECT
CHANGE STATE
CHANGE PASSWORD
WRITE PROTECT XXXX

OUTPUT MODE
STANDARD
REPLICATE

CALIBRATION
EXECUTE
ABORT

UNIT OF MEASURE
PPM
%
MG/M3

BACKLIGHT CTRL
OFF
ON
AUTOMATIC

HEATER CTRL
AUTOMATIC
OFF

WRITE PROTECT
CHANGE STATE
CHANGE PASSWORD
WRITE PROTECT XXXX

OP FEEDBACK FLT
OFF
ON

SCROLLING DISPLAY
DISABLED
ENABLED

GENERAL INFO
MANUFACTURER →
MODEL FGP_TX
TAG XXXXX
DESCRIPTOR XXXXX
DATE DD/MM/YYYY
MESSAGE XXXXX
FINAL ASSY NUM XXXXX
DEVICE ID XXXXX

DET-TRONICS
6901 WEST 110TH STREET
MINNEAPOLIS, MN 55438
USA

FAULT/STATUS
OP MODE XXXXX
CAL STATE XXXXX
TX STATUS Y/N
TX FAULT Y/N
SENSOR STATUS Y/N
SENSOR FAULT Y/N

TX INFO
RTC →
SERIAL NUMBER XXXXX
H/W REV XX.XX
F/W REV XX.XX
UNIVERSAL REV XXXXX
FIELD DEV REV XXXXX
S/W REV XX.XX
RUNNING HOURS XXXXX
TEMPERATURE XX.XXC

RTC
SECONDS XX
MINUTES XX
HOURS XX
DAY XX
MONTH XX
YEAR XX

SENSOR INFO
SENSITIVITY XXXXX
GAS TYPE XXXXX
SERIAL NUMBER XXXXX
H/W REV XX.XX
F/W REV XX.XX
REV XXXXX
USL XX.XX
LSL XX.XX
RUNNING HOURS XXXXX
CAL POINT ZERO XX.XX
CAL POINT SPAN XX.XX
PPM HOURS XXXXX
TEMPERATURE XX.XXC

HISTORY
TX HISTORY →
SENSOR HISTORY →
CALIBRATION LOG →
EVENT LOG →

DEBUG MENU
MODBUS ERRORS XXXX

BAUD RATE
1200
2400
4800
9600
19.2K

PARITY
NONE
EVEN
ODD

TX HISTORY
RUNNING HOURS XX:XX:XX
MAX TEMP XX.XX C
MAX TEMP TIME XX:XX:XX
MIN TEMP XX.XX C
MIN TEMP TIME XX:XX:XX

SENSOR HISTORY
RUNNING HOURS XXXX
MAX TEMP XX.XX C
MAX TEMP TIME XX:XX:XX
MIN TEMP XX.XX C
MIN TEMP TIME XX:XX:XX
RESET MAX MIN XX.XX C
MAX RESET TEMP XX.XX C
MIN RESET TEMP XX.XX C

CALIBRATION LOG
CAL ID XXX
DATE DD/MM/YYYY
TIME HH:MM:SS
ZERO XX.XX
SPAN XX.XX

EVENT LOG
EVENT XXXXX
DATE DD/MM/YYYY
TIME HH:MM:SS

TX STATUS
TX FAULT ON/OFF
WARM UP ON/OFF
CHANGE CONFIG ON/OFF
MULTI DROP ON/OFF
WRITE PROTECT ON/OFF
SELF TEST ON/OFF
RESPONSE TEST ON/OFF
CURRENT FIXED ON/OFF
LOOP TEST ON/OFF
FACTORY MODE ON/OFF
SNSR ASSY REMOVE ON/OFF

TX FAULT
EE FAULT ON/OFF
ADC FAULT ON/OFF
DAC FAULT ON/OFF
LOW VOLTAGE ON/OFF
FLASH CRC FAULT ON/OFF
RAM FAULT ON/OFF
TEMP FAULT ON/OFF
SOFTWARE FAULT ON/OFF
EE SAFETY FAULT ON/OFF
ZERO DRIFT FAULT ON/OFF
SENSOR MISMATCH ON/OFF
SENSOR FAULT ON/OFF

SENSOR STATUS
SENSOR FAULT ON/OFF
WARM UP ON/OFF
CAL ACTIVE ON/OFF
CAL SWITCH ON/OFF
WRITE PROTECT ON/OFF
EOL SENSOR ON/OFF
CHANGE CONFIG ON/OFF

SENSOR FAULT
CAL FAULT ON/OFF
EE FAULT ON/OFF
ADC FAULT ON/OFF
ADC CNTR FAULT ON/OFF
3V FAULT ON/OFF
ZERO DRIFT FAULT ON/OFF
FLASH CRC FAULT ON/OFF
RAM FAULT ON/OFF
TEMP FAULT ON/OFF
COMM FAULT ON/OFF
CELL MISSING FLT ON/OFF

GENERAL INFO
MANUFACTURER →
MODEL UD-10
TAG XXXXX
LONG TAG XXXXXX
DESCRIPTOR XXXXX
DATE DD/MM/YYYY
MESSAGE XXXXX
FINAL ASSY NUM XXXXX
DEVICE ID XXXXX

DET-TRONICS
6901 WEST 110TH STREET
MINNEAPOLIS, MN 55438
USA

FAULT/STATUS
OP MODE XXXXX
FAULT Y/N
STATUS Y/N

FAULT
LOW CAL LINE ON/OFF
EE FAULT ON/OFF
ADC FAULT ON/OFF
24V FAULT ON/OFF
FLASH FAULT ON/OFF
RAM FAULT ON/OFF
WDT FAULT ON/OFF
12V FAULT ON/OFF
5V FAULT ON/OFF
1.25V FAULT ON/OFF
O/P LOOP FAULT ON/OFF
0V FAULT ON/OFF
ADC REF FAULT ON/OFF

STATUS
ANY FAULT ON/OFF
CAL ACTIVE ON/OFF
WARM UP ON/OFF
LOW RELAY ACTIVE ON/OFF
HI RELAY ACTIVE ON/OFF
AUX RELAY ACTIVE ON/OFF
CURRENT FIXED ON/OFF
MB WRITE PROTECT ON/OFF
HART SELF TEST ON/OFF
LON ATTACHED ON/OFF
RESPONSE TEST ON/OFF
MANUAL SELF TEST ON/OFF
INPUT HART ON/OFF

HISTORY
DISPLAY HISTORY →
EVENT LOG →

DISPLAY HISTORY
RUNNING HOURS XXXX
MAX TEMP XX.XX C
MAX TEMP TIME XX:XX:XX
MIN TEMP XX.XX C
MIN TEMP TIME XX:XX:XX
RESET MAX MIN XX.XX C
MAX RESET TEMP XX.XX C
MIN RESET TEMP XX.XX C
MIN RESET TIME XX:XX:XX

DISPLAY INFO
RTC →
SERIAL NUMBER XXXXX
I/O BOARD ID XXX
MFG DATE DD/MM/YYYY
F/W REV XXXXX
UNIVERSAL REV XXXXX
FIELD DEV REV XXXXX
RUNNING HOURS XXXXX
TEMPERATURE XX.XX C
HEATER CTRL AUTO/ON/OFF
BACKLIGHT CTRL AUTO/ON/OFF
INPUT VOLTAGE XX.XX

EVENT LOG
EVENT XXXXX
DATE DD/MM/YYYY
TIME HH:MM:SS

RTC
DISPLAYED Y/N
SECONDS XX
MINUTES XX
HOURS XX
DAY XX
MONTH XX
YEAR XX

RS485
BAUD RATE XXXXX
PARITY XXXXX
POLL ADDRESS XXXXX

DEBUG MENU
HART ERRORS XXXXX
MODBUS ERRORS XXXXX
ERROR DETAILS →
OUTPUT READBACK XX.XX MA
ANALOG INPUT XX.XX MA
MAXIMUM CYCLE TIME XXXXX
AVERAGE CYCLE TIME XXXXX

ERROR DETAILS
HART MASTER →
HART SLAVE →
MODBUS →

APPENDIX H

UD10 with PIR9400 POINTWATCH IR GAS DETECTOR

NOTE

For complete information regarding the PIR9400 Gas Detector, refer to instruction manual 95-8440.

WIRING

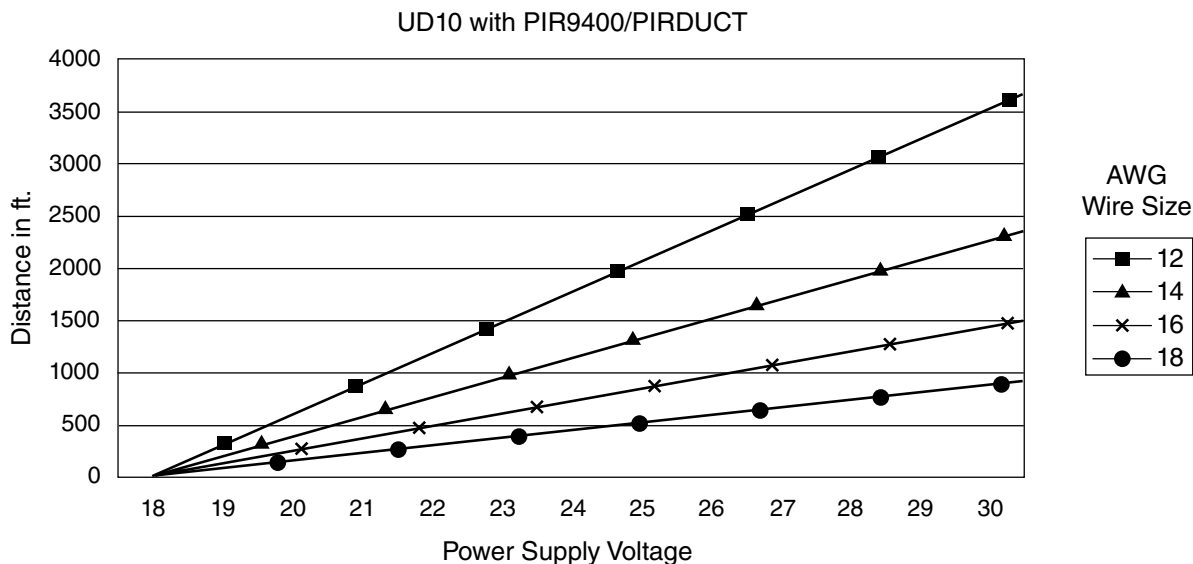

Notes: Maximum recommended cable length from power source to UD10 is 2000 feet.
 Maximum recommended cable length from UD10 to PIR9400/PIRTB termination box is 2000 feet.

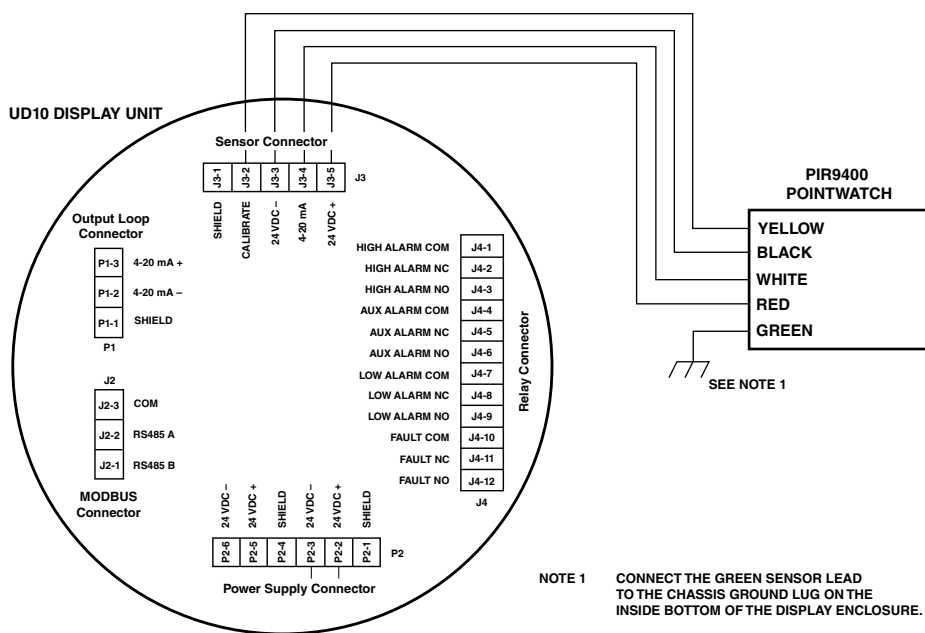

NOTE 1 CONNECT THE GREEN SENSOR LEAD TO THE CHASSIS GROUND LUG ON THE INSIDE BOTTOM OF THE DISPLAY ENCLOSURE.

NOTE 2 UD10 HOUSING MUST BE ELECTRICALLY CONNECTED TO EARTH GROUND.

PIR9400 Wired Directly to UD10

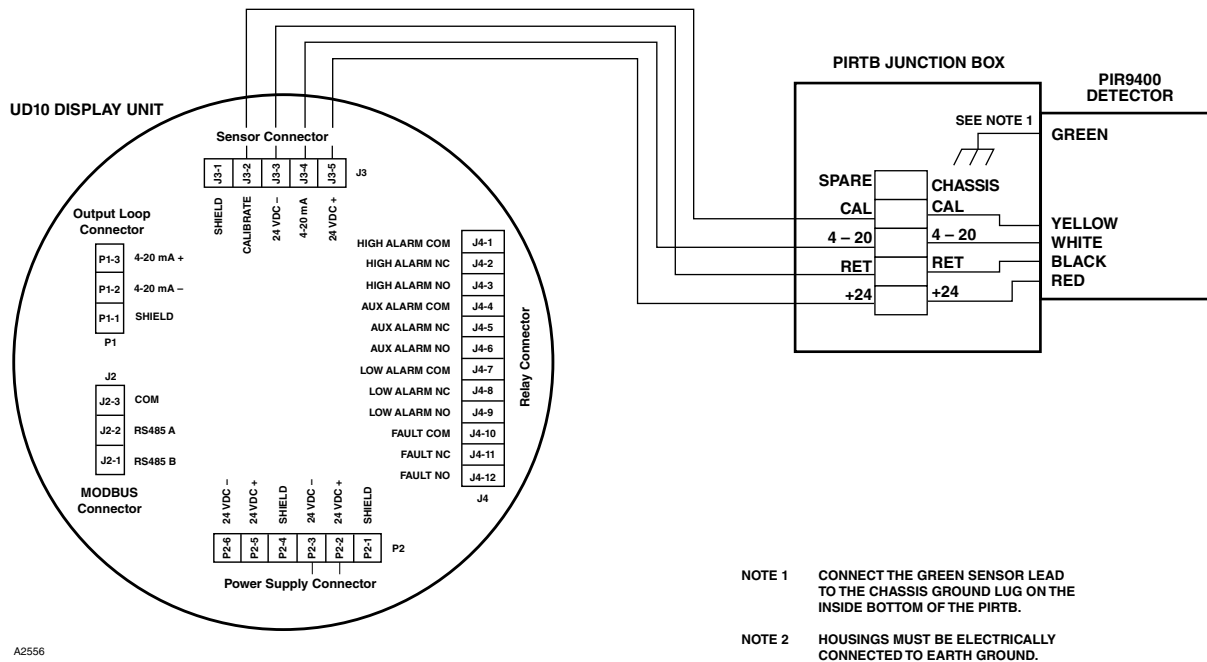

UD10 Wired to PIR9400 with PIRTB Termination Box

INSTALLATION NOTES

IMPORTANT

Hydrocarbon-based grease emits hydrocarbon vapors that will be measured by PointWatch, resulting in inaccurate gas level readings. **Use only low vapor pressure Lubriplate grease or Teflon tape on the PointWatch detector and associated termination box.** Do not get grease on the optics of the detector. A suitable grease is listed in the "Ordering Information" section of this manual.

IMPORTANT

In applications where both PointWatch and catalytic type sensors are used, ensure that the grease used to lubricate the PointWatch detector threads does not come into contact with the catalytic sensors, since poisoning of the catalytic sensors could result. It is strongly recommended that maintenance personnel wash their hands between handling the two types of sensors.

ORIENTATION

It is highly recommended that the PIR9400 be installed in the horizontal position. The detector is not position-sensitive in terms of its ability to detect gas. However, the weather baffle assembly provides superior performance when installed in a horizontal position. See illustration below.



CHANGING OPERATING MODES

When used with a PIR9400, the operating mode of the UD10 must be changed from “HART Device” to “PIR9400” mode. Refer to the “Startup” section of this manual for details.

CALIBRATION

To initiate calibration of the PIR9400 from the UD10 Display:

- Using the magnet to activate the switches on the UD10 display, navigate to the “Calibration” menu.

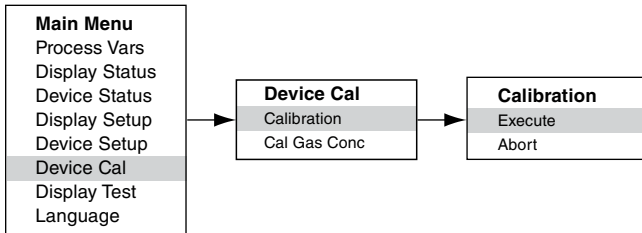

- Activate “Execute” (Enter/Select) to start calibration.
- The UD10 will display “Waiting for Zero” on the main display screen.
- The UD10 will then display “Waiting for Gas” on the screen.
- Apply calibration gas to the PIR9400.
- The UD10 will continue to display “Waiting for Gas” on the screen.
- When the UD10 displays “Remove Cal Gas” on the screen, remove the calibration gas from the PIR9400.
- The UD10 automatically returns to the normal mode after successful calibration.

To initiate calibration from the PIRTB Termination Box while monitoring calibration using the UD10 display:

- Using the magnet, activate the magnetic calibration switch on the PIRTB Termination Box. The LED at the PIRTB turns from off to steady red.
- The UD10 will display “Waiting for Zero” on the main display screen, with a steady red LED at the PIRTB.

| UD10 mA Output During Calibration (UD10 with PIR9400) | | |
|--|---------------|----------------|
| UD10 Display Reading | Standard Mode | Replicate Mode |
| Waiting for Zero | 3.8 | 2.2 |
| Waiting for Gas | 3.8 | 3.8 |
| Waiting for Span | 3.8 | 3.8 |
| Remove Cal Gas | 3.8 | 3.8 |
| Back to Normal | 4.0 | 4.0 |

- The UD10 will then display “Waiting for Gas” on the screen, while the LED at the PIRTB is flashing red.
- Apply calibration gas to the PIR9400 detector.
- The UD10 will display “Waiting for Span” on the screen, with a red flashing LED at the PIRTB.
- When the UD10 displays “Remove Cal Gas” on the screen and the LED at the PIRTB turns off, remove the calibration gas.
- After successful calibration, the UD10 automatically returns to the normal mode, and the LED on the PIRTB remains off.

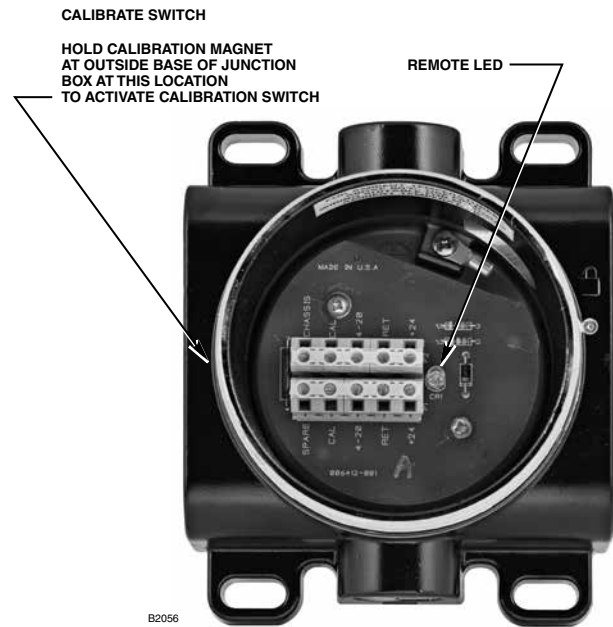

PIRTB Termination Box

MENU STRUCTURE

UD10 with PIR9400 PointWatch Detector

Refer to the following menu when using the UD10's LCD display and internal magnetic switches.

When connecting a HART Communicator to the UD10's 4-20 mA output, refer to the "UD10 HART Handheld" menu in Appendix F.

MENU HELP

Status menus only allow the user to view the data.

The Setup menus allow the user to both view and edit the data.

| PROCESS VARS | |
|---------------|---------|
| GAS NAME | XXXX |
| GAS VALUE | X.XX |
| HIGH ALARM | Y/N |
| LOW ALARM | Y/N |
| AUX ALARM | Y/N |
| ANALOG INPUT | X.XX MA |
| ANALOG OUTPUT | X.XX MA |
| URV | X.XX |
| LRV | X.XX |
| FAULT | Y/N |

| DISPLAY STATUS | |
|----------------|---|
| GENERAL INFO | → |
| FAULT/STATUS | → |
| HISTORY | → |
| DISPLAY INFO | → |
| RS485 | → |
| DEBUG MENU | → |

| DEVICE STATUS | |
|-----------------|---|
| DEVICE INFO | → |
| FAULT/STATUS | → |
| CALIBRATION LOG | → |

| DISPLAY SETUP | |
|--------------------|------|
| ALARM SETTING | → |
| MODE SELECT | → |
| HART OPTION | → |
| RTC | → |
| RS485 | → |
| INPUT LOOP CAL | → |
| CONTRAST CONTRL | → |
| OUTPUT MODE | → |
| BACKLIGHT CTRL | → |
| HEATER CTRL | → |
| WRITE PROTECT | → |
| OP FEEDBACK FLT | → |
| SCROLLING DISPLAY | → |
| SET SCROLLING RATE | XXX% |

| DEVICE SETUP | |
|---------------|---|
| DEVICE OPTION | → |

| DEVICE CAL | |
|--------------|-------|
| CALIBRATION | → |
| CAL GAS CONC | XX.XX |

| DISPLAY TEST | |
|---------------|---|
| SELF TEST | → |
| RESPONSE TEST | → |
| LOOP TEST | → |
| D/A TRIM | → |

| LANGUAGE | |
|-----------------|---|
| ENGLISH | → |
| SECOND LANGUAGE | → |

| DEVICE INFO | |
|-----------------|---------|
| MANUFACTURER | → |
| MODEL | PIR9400 |
| GAS NAME | XXXXX |
| UNIT OF MEASURE | XXXXX |
| URV | XX.XX |
| LRV | XX.XX |

| FAULTS/ STATUS | |
|----------------|-----|
| FAULTS | Y/N |

| CALIBRATION LOG | |
|-----------------|-------------|
| CAL ID | XXXX |
| DATE | DD/MMM/YYYY |
| TIME | HH:MM:SS |
| ZERO | XXXX |
| SPAN | XXXX |

| DEVICE OPTION | |
|-----------------|--------|
| GAS TYPE | → |
| GAS NAME | XXXXXX |
| UNIT OF MEASURE | %FL |
| URV | XX.XX |
| LRV | XX.XX |

| CALIBRATION | |
|-------------|---|
| EXECUTE | → |
| ABORT | → |

| LOOP TEST | |
|-------------|---|
| SET 4-20 MA | → |

| D/A TRIM | |
|-----------|---|
| ZERO TRIM | → |
| GAIN TRIM | → |

| DET-TRONICS | |
|------------------------|--|
| 6901 WEST 110TH STREET | |
| MINNEAPOLIS, MN 55438 | |
| USA | |

| FAULTS | |
|------------------|--------|
| WARM UP | ON/OFF |
| REF. CHANNEL FLT | ON/OFF |
| ACT CHANNEL FLT | ON/OFF |
| STARTUP CAL FLT | ON/OFF |
| 24 V FAULT | ON/OFF |
| BLOCK OPTICS | ON/OFF |
| CAL FAULT | ON/OFF |
| LOW FAULT | ON/OFF |
| HIGH FAULT | ON/OFF |

| GAS TYPE | |
|-----------|---|
| METHANE | → |
| ETHANE | → |
| PROPANE | → |
| PROPYLENE | → |
| ETHYLENE | → |

| SET 4-20 MA | |
|-------------|---|
| 3.5MA | → |
| 4 MA | → |
| 6 MA | → |
| 8 MA | → |
| 10 MA | → |
| 12 MA | → |
| 14 MA | → |
| 16 MA | → |
| 18 MA | → |
| 20 MA | → |

| ALARM SETTING | |
|------------------|-------|
| RST LATCH ALARMS | XX.XX |
| HGH ALARM LEVEL | Y/N |
| HGH ALARM LATCH | → |
| HGH ALARM NE/ND | XX.XX |
| LOW ALARM LEVEL | Y/N |
| LOW ALARM LATCH | → |
| LOW ALARM NE/ND | XX.XX |
| AUX ALARM LEVEL | Y/N |
| AUX ALARM LATCH | → |
| AUX ALARM NE/ND | → |

| HGH ALARM NE/NDE | |
|-------------------------|---|
| NE-NORMALY ENERGIZED | → |
| NDE-NORMALY DEENERGIZED | → |

| LOW ALARM NE/NDE | |
|-------------------------|---|
| NE-NORMALY ENERGIZED | → |
| NDE-NORMALY DEENERGIZED | → |

| AUX ALARM NE/NDE | |
|-------------------------|---|
| NE-NORMALY ENERGIZED | → |
| NDE-NORMALY DEENERGIZED | → |

| MODE SELECT | |
|-------------|----------------|
| HART DEVICE | PIR9400 |
| PIRDUCT | C706X |
| 505 | NTMOS |
| CGS | GENERIC DEVICE |

| HART OPTION | |
|----------------|-------------|
| TAG | XXXXX |
| LONG TAG | XXXXX |
| DESCRIPTOR | XXXXX |
| DATE | DD/MMM/YYYY |
| MESSAGE | XXXXX |
| FINAL ASSY NUM | XXXXX |

| RTC | |
|-----------|-----|
| DISPLAYED | Y/N |
| SECONDS | XX |
| MINUTES | XX |
| HOURS | XX |
| DAY | XX |
| MONTH | XX |
| YEAR | XX |

| BAUD RATE | |
|-----------|---|
| 1200 | → |
| 2400 | → |
| 4800 | → |
| 9600 | → |
| 19.2K | → |

| RS485 | |
|--------------|------|
| BAUD RATE | → |
| PARITY | → |
| POLL ADDRESS | XXXX |

| PARITY | |
|--------|---|
| NONE | → |
| EVEN | → |
| ODD | → |

| OUTPUT MODE | |
|-------------|---|
| STANDARD | → |
| REPLICATE | → |

| BACKLIGHT CTRL | |
|----------------|---|
| OFF | → |
| ON | → |
| AUTOMATIC | → |

| HEATER CTRL | |
|-------------|---|
| AUTOMATIC | → |
| OFF | → |

| WRITE PROTECT | |
|-----------------|------|
| CHANGE STATE | → |
| CHANGE PASSWORD | → |
| WRITE PROTECT | XXXX |

| OP FEEDBACK FLT | |
|-----------------|---|
| OFF | → |
| ON | → |

| SCROLLING DISPLAY | |
|-------------------|---|
| DISABLED | → |
| ENABLED | → |

| GENERAL INFO | |
|----------------|-------------|
| MANUFACTURER | → |
| MODEL | UD-10 |
| TAG | XXXXX |
| LONG TAG | XXXXXX |
| DESCRIPTOR | XXXXX |
| DATE | DD/MMM/YYYY |
| MESSAGE | XXXXX |
| FINAL ASSY NUM | XXXXX |
| DEVICE ID | XXXXX |

| DET-TRONICS | |
|------------------------|--|
| 6901 WEST 110TH STREET | |
| MINNEAPOLIS, MN 55438 | |
| USA | |

| FAULT | |
|------------------|--------|
| LOW CAL LINE | ON/OFF |
| EE FAULT | ON/OFF |
| ADC FAULT | ON/OFF |
| 24V FAULT | ON/OFF |
| FLASH FAULT | ON/OFF |
| RAM FAULT | ON/OFF |
| WDT FAULT | ON/OFF |
| 12V FAULT | ON/OFF |
| 5V FAULT | ON/OFF |
| 1.25V FAULT | ON/OFF |
| O/P LOOP FAULT | ON/OFF |
| INPUT LOOP FAULT | ON/OFF |
| 0V FAULT | ON/OFF |
| ADC REF FAULT | ON/OFF |

| FAULT/STATUS | |
|--------------|-------|
| OP MODE | XXXXX |
| FAULT | Y/N |
| STATUS | Y/N |

| STATUS | |
|------------------|--------|
| ANY FAULT | ON/OFF |
| CAL ACTIVE | ON/OFF |
| WARM UP | ON/OFF |
| LOW RELAY ACTIVE | ON/OFF |
| HI RELAY ACTIVE | ON/OFF |
| AUX RELAY ACTIVE | ON/OFF |
| CURRENT FIXED | ON/OFF |
| MB WRITE PROTECT | ON/OFF |
| HART SELF TEST | ON/OFF |
| LON ATTACHED | ON/OFF |
| RESPONSE TEST | ON/OFF |
| MANUAL SELF TEST | ON/OFF |
| INPUT HART | ON/OFF |

| DISPLAY HISTORY | |
|-----------------|----------|
| RUNNING HOURS | XXXX |
| MAX TEMP | XX.XX C |
| MAX TEMP TIME | XX:XX:XX |
| MIN TEMP | XX.XX C |
| MIN TEMP TIME | XX:XX:XX |
| RESET MAX MIN | XX.XX C |
| MAX RESET TIME | XX:XX:XX |
| MIN RESET TIME | XX.XX C |
| MIN RESET TIME | XX:XX:XX |

| HISTORY | |
|-----------------|---|
| DISPLAY HISTORY | → |
| EVENT LOG | → |

| EVENT LOG | |
|-----------|-------------|
| EVENT | XXXXX |
| DATE | DD/MMM/YYYY |
| TIME | HH:MM:SS |

| DISPLAY INFO | |
|----------------|-------------|
| RTC | → |
| SERIAL NUMBER | XXXXX |
| I/O BOARD ID | XXX |
| MFG DATE | DD/MM/YYYY |
| F/W REV | XXXXX |
| UNIVERSAL REV | XXXXX |
| FIELD DEV REV | XXXXX |
| RUNNING HOURS | XXXXX |
| TEMPERATURE | XX.XX C |
| HEATER CTRL | AUTO/ON/OFF |
| BACKLIGHT CTRL | AUTO/ON/OFF |
| INPUT VOLTAGE | XX.XX |

| RTC | |
|-----------|-----|
| DISPLAYED | Y/N |
| SECONDS | XX |
| MINUTES | XX |
| HOURS | XX |
| DAY | XX |
| MONTH | XX |
| YEAR | XX |

| RS485 | |
|--------------|-------|
| BAUD RATE | XXXXX |
| PARITY | XXXXX |
| POLL ADDRESS | XXXXX |

| DEBUG MENU | |
|--------------------|----------|
| HART ERRORS | XXXXX |
| MODBUS ERRORS | XXXXX |
| ERROR DETAILS | → |
| OUTPUT READBACK | XX.XX MA |
| ANALOG INPUT | XX.XX MA |
| MAXIMUM CYCLE TIME | XXXXX |
| AVERAGE CYCLE TIME | XXXXX |

| ERROR DETAILS | |
|---------------|---|
| HART MASTER | → |
| HART SLAVE | → |
| MODBUS | → |

APPENDIX I

UD10 with MODEL PIRECL

NOTE

For complete information regarding the PIRECL Gas Detector, refer to instruction manual 95-8526.

WIRING

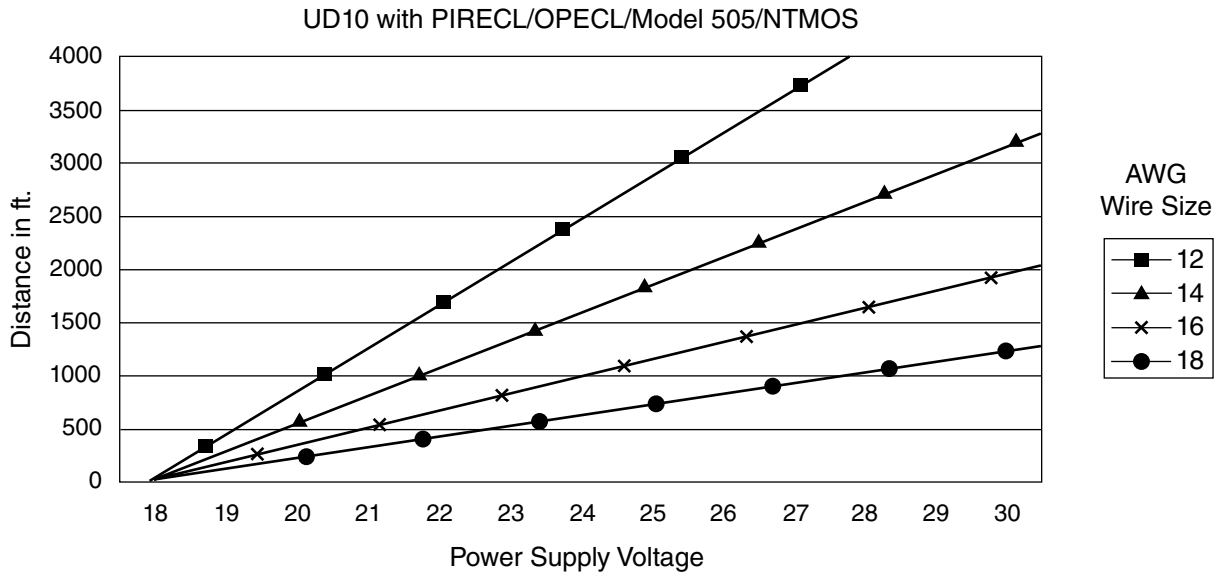

Notes: Maximum recommended cable length from power source to UD10 is 2000 feet.
Maximum recommended cable length from UD10 to detector/STB termination box is 2000 feet.

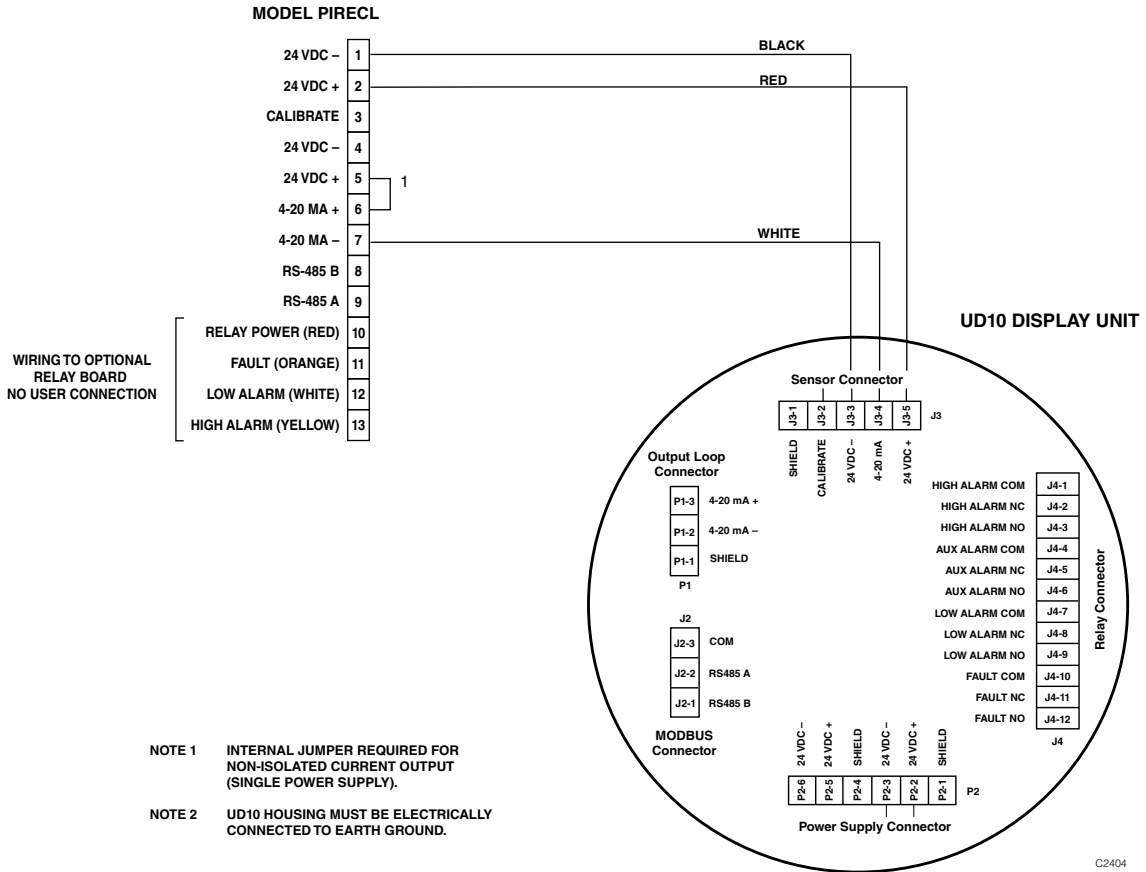

Model PIRECL Wired Directly to UD10

ORIENTATION

It is highly recommended that the PIRECL be installed in the horizontal position. The detector is not position-sensitive in terms of its ability to detect gas. However, the weather baffle assembly provides superior performance when the PIRECL is installed with the baffle in a horizontal position.



CORRECT



INCORRECT

CALIBRATION

To initiate calibration of the PIRECL from the UD10 Display:

- Using the magnet to activate the switches on the UD10 display, navigate to the "Calibration" menu.

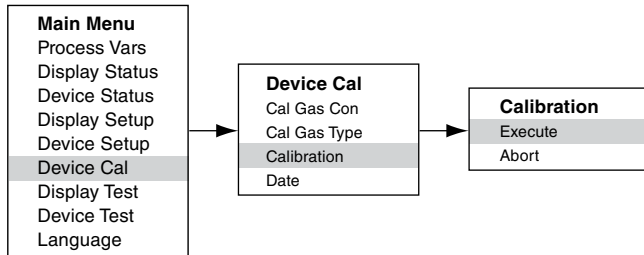

- Activate "Execute" (Enter/Select) to start calibration.
- The UD10 will display "Waiting for Zero" on the main display screen, with a solid red LED on the PIRECL housing illuminated.
- The UD10 will then display "Waiting for Gas" on the screen, while the LED on the PIRECL is flashing red.
- Apply calibration gas to the PIRECL
- The UD10 will display "Waiting for Span" on the screen, while a red flashing LED on the PIRECL housing is illuminated.
- When the UD10 displays "Remove Cal Gas" on the screen and the LED on the PIRECL housing is off, remove the calibration gas.
- After successful calibration, the UD10 automatically returns to the normal display with the green LED illuminated on the PIRECL housing.

To initiate calibration from the PIRECL while monitoring calibration using the UD10 display:

- Using the magnet, activate the magnetic calibration switch on the PIRECL detector. See Figure below. The LED turns from green to red.
- The UD10 will display "Waiting for Zero" on the main display screen, with a solid red LED on the PIRECL housing illuminated.
- The UD10 will then display "Waiting for Gas" on the screen, while the LED on the PIRECL is flashing red.
- Apply calibration gas to the PIRECL detector.
- The UD10 will display "Waiting for Span" on the screen, while a red flashing LED on the PIRECL housing is illuminated.
- When the UD10 displays "Remove Cal Gas" on the screen and the LED on the PIRECL housing is off, remove the calibration gas.
- After successful calibration, the UD10 automatically returns to the normal mode with the green LED illuminated on the PIRECL.

| UD10 mA Output During Calibration (UD10 with PIRECL) | | |
|---|---------------|----------------|
| UD10 Display Reading | Standard Mode | Replicate Mode |
| Waiting for Zero | 3.8 | 2.2 |
| Waiting for Gas | 3.8 | 2.0 |
| Waiting for Span | 3.8 | 2.0 |
| Remove Cal Gas | 3.8 | 1.8 |
| Back to Normal | 4.0 | 4.0 |

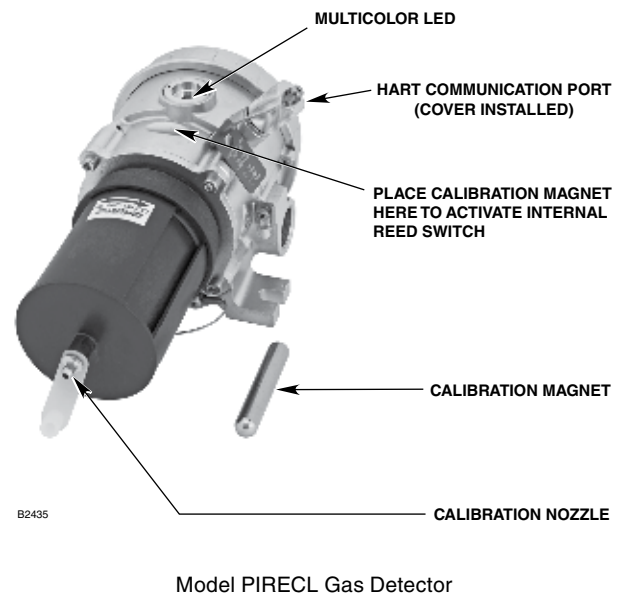

MENU STRUCTURE

UD10 with Model PIRECL

Refer to the following menu when using the UD10's LCD display and internal magnetic switches.

When connecting a HART Communicator to the UD10's 4-20 mA output, refer to the "UD10 HART Handheld" menu in Appendix F.

MENU HELP

Status menus only allow the user to view the data.

The Setup menus allow the user to both view and edit the data.

MAIN MENU

- PROCESS VARS →
- DISPLAY STATUS →
- DEVICE STATUS →
- DISPLAY SETUP →
- DEVICE CAL →
- DISPLAY TEST →
- DEVICE TEST →
- LANGUAGE →

PROCESS VARS

| | |
|---------------|---------|
| GAS NAME | XXXXXX |
| GAS VALUE | X.XX |
| HIGH ALARM | Y/N |
| LOW ALARM | Y/N |
| AUX ALARM | Y/N |
| ANALOG INPUT | X.XX MA |
| ANALOG OUTPUT | X.XX MA |
| URV | X.XX |
| LRV | X.XX |
| FAULT | Y/N |

DISPLAY STATUS

- GENERAL INFO →
- FAULT/STATUS →
- HISTORY →
- DISPLAY INFO →
- RS485 →
- DEBUG MENU →

DEVICE STATUS

- GENERAL INFO →
- FAULT/STATUS →
- DEVICE INFO →
- SENSOR INFO →
- HISTORY →

DISPLAY SETUP

- ALARM SETTING →
- MODE SELECT →
- HART OPTION →
- RTC →
- RS485 →
- INPUT LOOP CAL →
- CONTRAST CONTRL →
- OUTPUT MODE →
- BACKLIGHT CTRL →
- HEATER CTRL →
- WRITE PROTECT →
- OP FEEDBACK FLT →
- SCROLLING DISPLAY →
- SET SCROLLING RATE XXX%

DEVICE SETUP

- DEVICE OPTION →
- ALARM SETTING →
- HART OPTION →
- RS485 →
- WRITE PROTECT →

DEVICE CAL

| | |
|--------------|-------------|
| CAL GAS CONC | XX.XX |
| CAL GAS TYPE | → |
| CALIBRATION | → |
| CAL DATE | DD/MMM/YYYY |

DISPLAY TEST

- SELF TEST →
- RESPONSE TEST →
- LOOP TEST →
- D/A TRIM →

DEVICE TEST

- SELF TEST →
- RESPONSE TEST →
- LOOP TEST →
- D/A TRIM →

LANGUAGE

- ENGLISH
- SECOND LANGUAGE

ALARM SETTING

| | |
|------------------|-------|
| RST LATCH ALARMS | |
| HGH ALARM LEVEL | XX.XX |
| HGH ALARM LATCH | Y/N |
| HGH ALARM NE/ND | → |
| LOW ALARM LEVEL | XX.XX |
| LOW ALARM LATCH | Y/N |
| LOW ALARM NE/ND | → |
| AUX ALARM LEVEL | XX.XX |
| AUX ALARM LATCH | Y/N |
| AUX ALARM NE/ND | → |

DEVICE OPTION

- GAS TYPE →
- UNIT OF MEASURE →
- URV XX.XX
- LRV XX.XX
- USL XX.XX
- LSL XX.XX
- ANALOG CODE VAL →
- ANALOG FLT CODE →

GAS TYPE

- METHANE
- ETHANE
- PROPANE
- ETHYLENE
- PROPYLENE
- BUTANE
- SPECIAL

ALARM SETTING

| | |
|------------------|-------|
| RST LATCH ALARMS | |
| HGH ALARM LEVEL | XX.XX |
| HGH ALARM LATCH | Y/N |
| LOW ALARM LEVEL | XX.XX |
| LOW ALARM LATCH | Y/N |

HART OPTION

| | |
|----------------|-------------|
| TAG | XXXXX |
| LONG TAG | XXXXX |
| DESCRIPTOR | XXXXX |
| DATE | DD/MMM/YYYY |
| MESSAGE | XXXXX |
| FINAL ASSY NUM | XXXXX |

UNIT OF MEASURE

- %LFL
- PPM
- VOL%

ANALOG CODE VAL

| | |
|---------------|-------|
| WARM UP | XX.XX |
| BLOCKED OPTIC | XX.XX |
| CALIBRATION | XX.XX |
| FAULT | XX.XX |

RS485

- BAUD RATE →
- PARITY →
- POLL ADDRESS XXX

ANALOG FAULT CODE

- ECLIPSE
- PIR9400
- USER DEFINED

WRITE PROTECT

- CHANGE STATE
- CHANGE PASSWORD
- WRITE PROTECT XXXX

BAUD RATE

- 1200
- 2400
- 4800
- 9600
- 19.2K

PARITY

- NONE
- EVEN
- ODD

DEVICE CAL

- CAL GAS TYPE →
- SAME AS MEASURE GAS
- METHANE
- PROPANE

CALIBRATION

- EXECUTE
- ABORT

DISPLAY TEST

- SELF TEST →
- RESPONSE TEST →
- LOOP TEST →
- D/A TRIM →

LOOP TEST

- SET 4-20 MA →

LOOP TEST

- 3.5 MA
- 4-MA
- 6 MA
- 8 MA
- 10 MA
- 12 MA
- 14-MA
- 16-MA
- 18-MA
- 20 MA

DEVICE TEST

- SELF TEST →
- RESPONSE TEST →
- LOOP TEST →
- D/A TRIM →

D/A TRIM

- ZERO TRIM
- GAIN TRIM

SET 4-20 MA

- 3.5 MA
- 4 MA
- 6 MA
- 8 MA
- 10 MA
- 12 MA
- 14 MA
- 16 MA
- 18 MA
- 20 MA

LANGUAGE

- ZERO TRIM
- GAIN TRIM

HGH ALARM NE/NDE

- NE-NORMALLY ENERGIZED
- NDE-NORMALLY DEENERGIZED

LOW ALARM NE/NDE

- NE-NORMALLY ENERGIZED
- NDE-NORMALLY DEENERGIZED

AUX ALARM NE/NDE

- NE-NORMALLY ENERGIZED
- NDE-NORMALLY DEENERGIZED

MODE SELECT

- HART DEVICE
- PIR9400
- PIRDUCT
- C706X
- 505
- NTMOS
- CGS
- GENERIC DEVICE

HART OPTION

| | |
|----------------|-------------|
| TAG | XXXXX |
| LONG TAG | XXXXX |
| DESCRIPTOR | XXXXX |
| DATE | DD/MMM/YYYY |
| MESSAGE | XXXXX |
| FINAL ASSY NUM | XXXXX |

RTC

| | |
|-----------|-------|
| DISPLAYED | Y/N |
| SECONDS | XXXXX |
| MINUTES | XXXXX |
| HOURS | XXXXX |
| DAY | XXXXX |
| MONTH | XXXXX |
| YEAR | XXXXX |

RS485

- BAUD RATE →
- PARITY →
- POLL ADDRESS XXXX

OUTPUT MODE

- STANDARD
- REPLICATE

BACKLIGHT CTRL

- OFF
- ON
- AUTOMATIC

HEATER CTRL

- AUTOMATIC
- OFF

WRITE PROTECT

- CHANGE STATE
- CHANGE PASSWORD
- WRITE PROTECT XXXX

OP FEEDBACK FLT

- OFF
- ON

SCROLLING DISPLAY

- DISABLED
- ENABLED

GENERAL INFO

| | |
|----------------|-------------|
| MANUFACTURER | → |
| MODEL | UD-10 |
| TAG | XXXXX |
| LONG TAG | XXXXXX |
| DESCRIPTOR | XXXXX |
| DATE | DD/MMM/YYYY |
| MESSAGE | XXXXX |
| FINAL ASSY NUM | XXXXX |
| DEVICE ID | XXXXX |

DET-TRONICS
6901 WEST 110TH STREET
MINNEAPOLIS, MN 55438
USA

FAULT/STATUS

| | |
|-----------|-------|
| OP MODE | XXXXX |
| CAL STATE | XXXXX |
| FAULT | Y/N |
| STATUS | Y/N |

DEVICE INFO

| | |
|---------------|-------|
| SERIAL NUMBER | XXXXX |
| UNIVERSAL REV | XXXXX |
| FIELD DEV REV | XXXXX |
| S/W REV | XXXXX |

SENSOR INFO

| | |
|-------------|--------|
| ACTIVE | XX.XX |
| REFERENCE | XX.XX |
| RATIO | XX.XX |
| ABSORPTION | XX.XX |
| TEMPERATURE | XX.XXC |
| VOL % | XX.XX |
| USL | XX.XX |
| LSL | XX.XX |
| SPAN FACTOR | XX.XX |

HISTORY

- DEVICE HISTORY →
- CALIBRATION LOG →
- EVENT LOG →

BAUD RATE

- 1200
- 2400
- 4800
- 9600
- 19.2K

PARITY

- NONE
- EVEN
- ODD

FAULT

| | |
|------------------|--------|
| CAL FAULT | ON/OFF |
| DIRTY OPTICS | ON/OFF |
| LAMP FAULT | ON/OFF |
| START CAL FAULT | ON/OFF |
| EE 1 FAULT | ON/OFF |
| EE 2 FAULT | ON/OFF |
| REF ADC SAT | ON/OFF |
| ACTIVE ADC SAT | ON/OFF |
| 24V FAULT | ON/OFF |
| 12V FAULT | ON/OFF |
| 5V FAULT | ON/OFF |
| ZERO DRIFT FAULT | ON/OFF |
| FLASH CRC FAULT | ON/OFF |
| RAM FAULT | ON/OFF |

STATUS

| | |
|----------------|--------|
| CAL ACTIVE | ON/OFF |
| WARM UP | ON/OFF |
| LOW ALARM | ON/OFF |
| HIGH ALARM | ON/OFF |
| HART SELF TEST | ON/OFF |
| CHANGE CONFIG | ON/OFF |

DEVICE HISTORY

| | |
|----------------|---------|
| RUNNING HOURS | XXXXX |
| MAX TEMP | XX.XX C |
| MAX TEMP TIME | XXXX |
| MIN TEMP | XX.XX C |
| MIN TEMP TIME | XXXX |
| RESET MAX MIN | XX.XX C |
| MAX RESET TEMP | XXXX |
| MIN RESET TEMP | XX.XX C |
| MIN RESET TIME | XXXX |

CALIBRATION LOG

| | |
|--------|-------|
| CAL ID | XXXXX |
| HOURS | XXXXX |

EVENT LOG

| | |
|-------|-------|
| EVENT | XXXXX |
| HOURS | XXXXX |

GENERAL INFO

| | |
|----------------|-------------|
| MANUFACTURER | → |
| MODEL | UD-10 |
| TAG | XXXXX |
| LONG TAG | XXXXX |
| DESCRIPTOR | XXXXX |
| DATE | DD/MMM/YYYY |
| MESSAGE | XXXXX |
| FINAL ASSY NUM | XXXXX |
| DEVICE ID | XXXXX |

DET-TRONICS
6901 WEST 110TH STREET
MINNEAPOLIS, MN 55438
USA

FAULT/STATUS

| | |
|---------|-------|
| OP MODE | XXXXX |
| FAULT | Y/N |
| STATUS | Y/N |

FAULT

| | |
|------------------|--------|
| LOW CAL LINE | ON/OFF |
| EE FAULT | ON/OFF |
| ADC FAULT | ON/OFF |
| 24V FAULT | ON/OFF |
| FLASH FAULT | ON/OFF |
| RAM FAULT | ON/OFF |
| WDT FAULT | ON/OFF |
| 12V FAULT | ON/OFF |
| 5V FAULT | ON/OFF |
| 1.25V FAULT | ON/OFF |
| O/P LOOP FAULT | ON/OFF |
| INPUT LOOP FAULT | ON/OFF |
| 0V FAULT | ON/OFF |
| ADC REF FAULT | ON/OFF |

STATUS

| | |
|------------------|--------|
| ANY FAULT | ON/OFF |
| CAL ACTIVE | ON/OFF |
| WARM UP | ON/OFF |
| LOW RELAY ACTIVE | ON/OFF |
| HI RELAY ACTIVE | ON/OFF |
| AUX RELAY ACTIVE | ON/OFF |
| CURRENT FIXED | ON/OFF |
| MB WRITE PROTECT | ON/OFF |
| HART SELF TEST | ON/OFF |
| LON ATTACHED | ON/OFF |
| RESPONSE TEST | ON/OFF |
| MANUAL SELF TEST | ON/OFF |
| INPUT HART | ON/OFF |

HISTORY

- DISPLAY HISTORY →
- EVENT LOG →

DISPLAY HISTORY

| | |
|----------------|----------|
| RUNNING HOURS | XXXX |
| MAX TEMP | XX.XX C |
| MAX TEMP TIME | XX:XX:XX |
| MIN TEMP | XX.XX C |
| MIN TEMP TIME | XX:XX:XX |
| RESET MAX MIN | XX.XX C |
| MAX RESET TEMP | XX:XX:XX |
| MIN RESET TEMP | XX.XX C |
| MIN RESET TIME | XX:XX:XX |

DISPLAY INFO

| | |
|----------------|-------------|
| RTC | → |
| SERIAL NUMBER | XXXXX |
| I/O BOARD ID | XXX |
| MFG DATE | DD/MMM/YYYY |
| F/W REV | XXXXX |
| UNIVERSAL REV | XXXXX |
| FIELD DEV REV | XXXXX |
| RUNNING HOURS | XXXXX |
| TEMPERATURE | XX.XX C |
| HEATER CTRL | AUTO/ON/OFF |
| BACKLIGHT CTRL | AUTO/ON/OFF |
| INPUT VOLTAGE | XX.XX |

EVENT LOG

| | |
|-------|-------------|
| EVENT | XXXXX |
| DATE | DD/MMM/YYYY |
| TIME | HH:MM:SS |

RS485

- BAUD RATE XXXX
- PARITY XXXX
- POLL ADDRESS XXXX

RTC

| | |
|-----------|-------|
| DISPLAYED | Y/N |
| SECONDS | XXXXX |
| MINUTES | XXXXX |
| HOURS | XXXXX |
| DAY | XXXXX |
| MONTH | XXXXX |
| YEAR | XXXXX |

DEBUG MENU

- HART ERRORS XXXXX
- MODBUS ERRORS XXXXX
- ERROR DETAILS →
- OUTPUT READBACK XX.XX MA
- ANALOG INPUT XX.XX MA
- MAXIMUM CYCLE TIME XXXXX
- AVERAGE CYCLE TIME XXXXX

ERROR DETAILS

- HART MASTER →
- HART SLAVE →
- MODBUS →

APPENDIX J

UD10 with OPEN PATH ECLIPSE MODEL OPECL

NOTE

For complete information regarding the OPECL Gas Detector, refer to instruction manual 95-8556.

WIRING

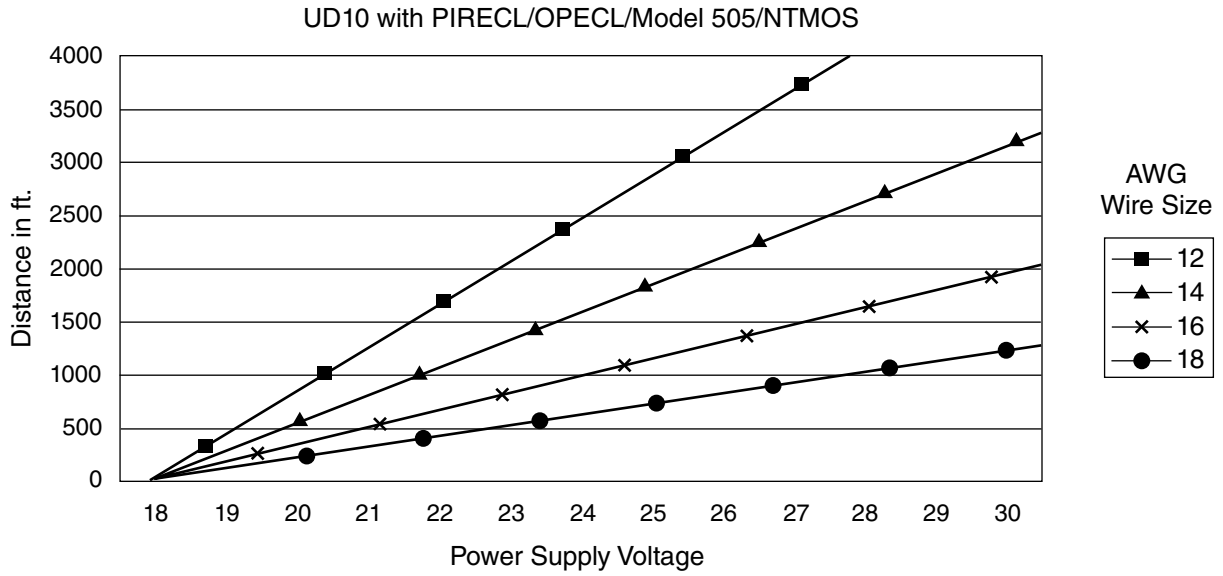

Notes: Maximum recommended cable length from power source to UD10 is 2000 feet.
Maximum recommended cable length from UD10 to detector/STB termination box is 2000 feet.

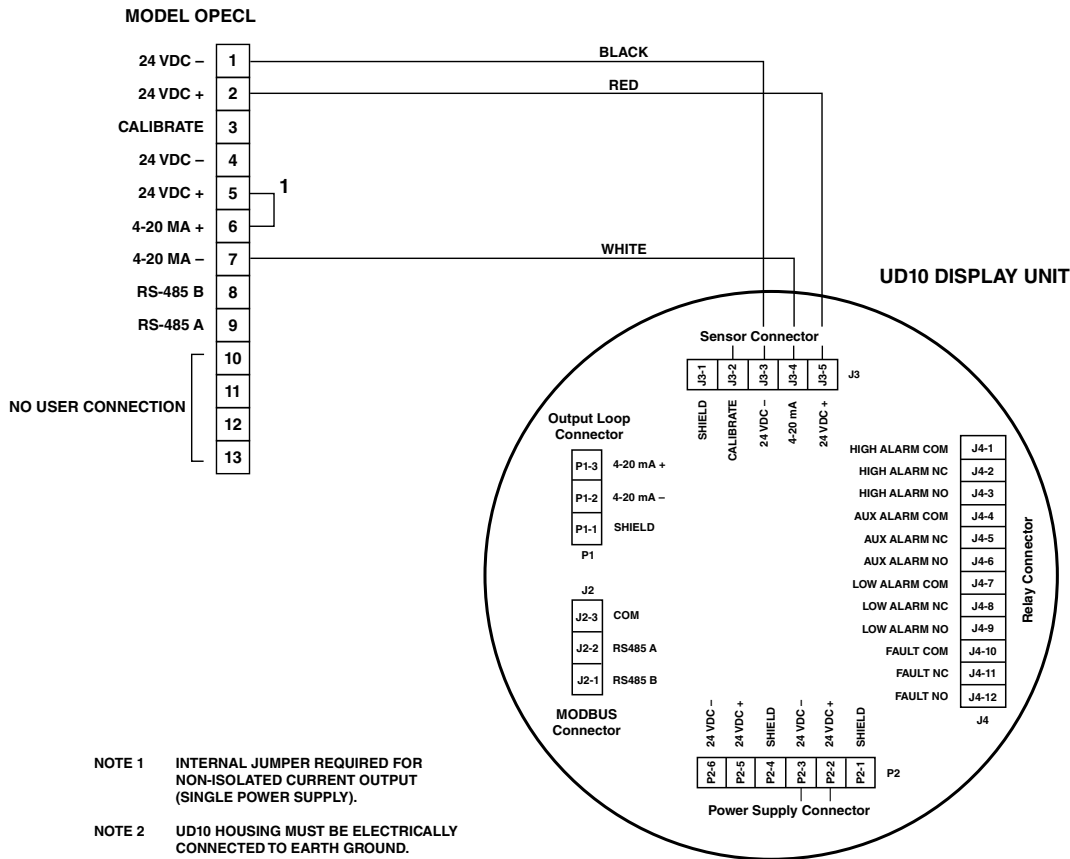

C2405

Model OPECL Wired Directly to UD10

ORIENTATION

OPECL modules must be affixed to a solid, non-vibrating structure capable of supporting a minimum of 100 lbs (46 kg), located within the system's rated separation distance. See examples below.

In all cases, the maximum movement of the supporting structure under all anticipated operating conditions must be no more than ± 0.25 degrees. When using a vertical post, the post should be absolutely stable and without vibration. Generally, when the post is set into the ground, the portion below grade should be set in concrete at least 1 meter deep.

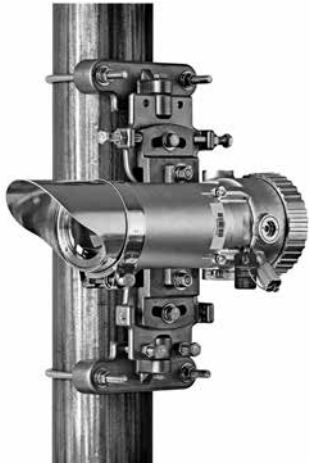

CALIBRATION

To initiate zero calibration of the OPECL from the UD10 Display:

- Using the magnet to activate the switches on the UD10 display, navigate to the "Zero Calibration" menu.

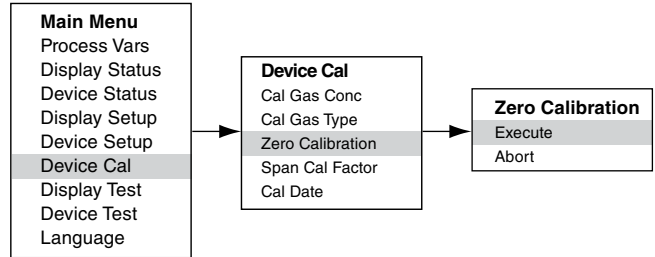

- Activate "Execute" (Enter/Select) to start calibration.
- The UD10 will display "Waiting for Zero" on the main display screen, with a solid red LED on the OPECL housing illuminated.
- After the calibration is successfully completed, the UD10 automatically returns to the normal display with the green LED illuminated on the OPECL housing.

| UD10 mA Output During Calibration (UD10 with OPECL) | | |
|--|---------------|----------------|
| UD10 Display Reading | Standard Mode | Replicate Mode |
| Waiting for Zero | 3.8 | 2.2 |
| Back to Normal | 4.0 | 4.0 |

To initiate zero calibration from the OPECL:

1. Using the magnet, activate the magnetic calibration switch on the OPECL receiver. See Figure below. The green LED will turn red.
2. The UD10 will display “Waiting for Zero” on the main display screen, with a solid red LED on the OPECL housing illuminated.
3. After the calibration is successfully completed, the UD10 automatically returns to the normal display with the green LED illuminated on the OPECL housing.

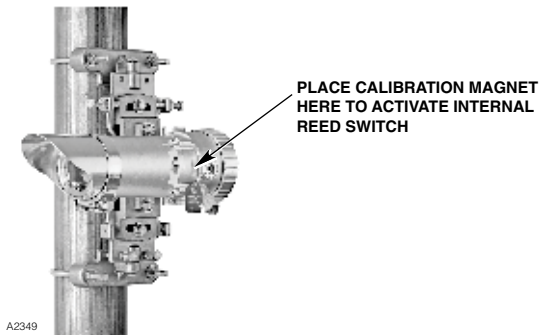

Location of Receiver's Internal Magnetic Switch

OPECL TRANSMITTER LAMP FAULT CONDITION

If the OPECL system experiences a Transmitter (Tx) Lamp Fault condition, the UD10 display will not indicate a fault condition and its output will remain at 4 mA. The OPECL system is still fully functional and able to detect gas. If a gas alarm condition should occur, the alarm condition will override the Tx Lamp Fault condition.

The OPECL system indicates a fault condition by amber indicator LEDs on both the transmitter and the receiver.

To verify an OPECL Tx Lamp Fault condition, within the Menu Structure of the UD10 Display navigate to the device “Fault/Status” menu:

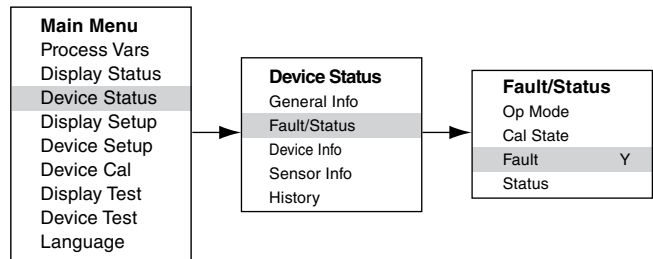

The Fault status will indicate Y (Yes). Click on “Fault” and the Fault menu will identify the fault as a “Lamp Fault.”

For complete information regarding OPECL fault indications and operation of the OPECL transmitter lamps, refer to the OPECL instruction manual, number 95-8556.

MENU STRUCTURE

UD10 with Open Patch Eclipse Model OPECL

Refer to the following menu when using the UD10's LCD display and internal magnetic switches.

When connecting a HART Communicator to the UD10's 4-20 mA output, refer to the “UD10 HART Handheld” menu in Appendix F.

MENU HELP

Status menus only allow the user to view the data. The Setup menus allow the user to both view and edit the data.

APPENDIX K

UD10 with NTMOS H₂S DETECTOR

NOTE

For complete information regarding the NTMOS Gas Detector, refer to instruction manual 95-8604.

WIRING

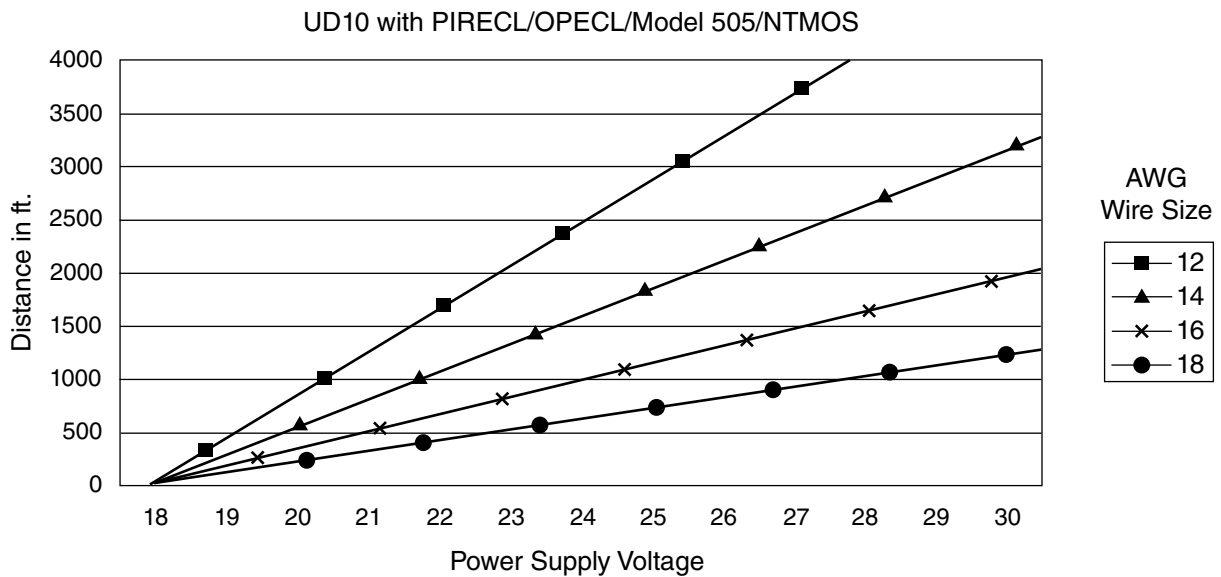

Notes: Maximum recommended cable length from power source to UD10 is 2000 feet.
Maximum recommended cable length from UD10 to detector/STB termination box is 2000 feet.

INSTALLATION NOTES

NOTE

Never use silicone grease with the NTMOS detector.

NOTE

A junction box spacer or standoff may be used to increase the distance between the device and the mounting surface, thereby facilitating installation and use of the ampoule calibrator.

NOTE

For non-HART applications, the NTMOS detector can be wired to the Sensor Connector terminals (J3) on the UD10 module. If HART communication will be used, the NTMOS detector must be wired to the optional NTMOS Connector Board, located on the inside bottom of the UD10 housing. Refer to the appropriate wiring diagram.

Proper Termination of Orange and Grey Wires

The orange and grey wires on the NTMOS detector are for factory use only. Proper field termination of these wires can be accomplished in any of the following ways:

- If wiring to optional NTMOS Connector Board, use the terminals provided (grey to COM 1 & orange to COM 2).
- If codes allow, they can be taped off and left unconnected.
- Connect both wires to the "Shield" terminal (J3-1).
- Connect both wires to Power Supply Minus (24 Vdc -).
- Connect to unused terminals in the STB Sensor Termination Box.

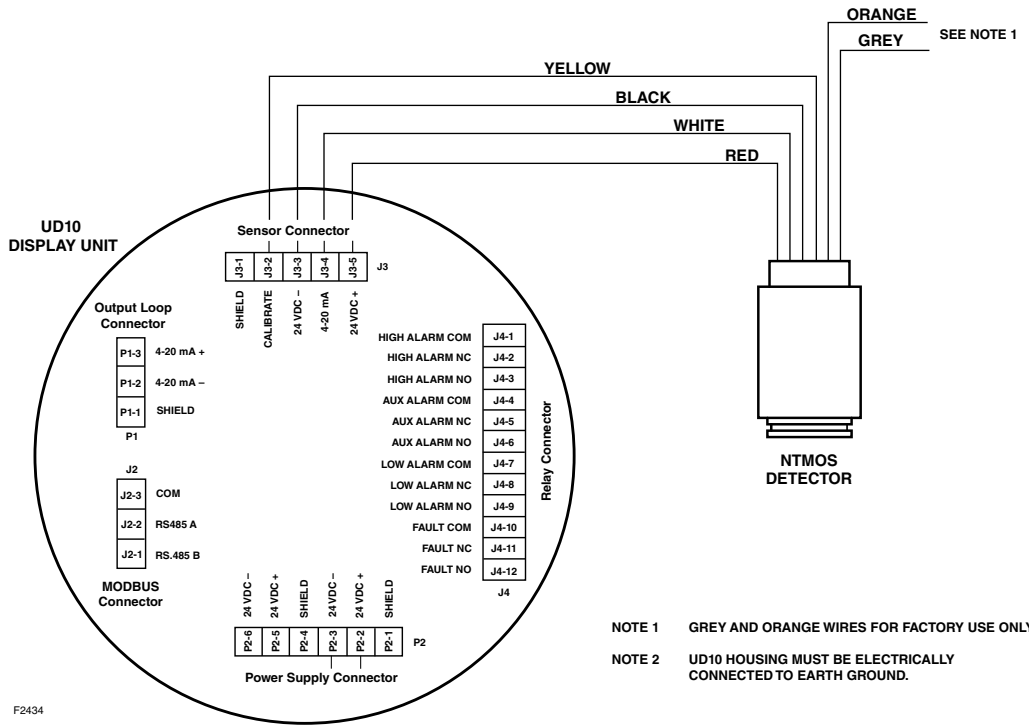

NTMOS Detector Wired Directly to UD10 (Non-HART Applications Only)

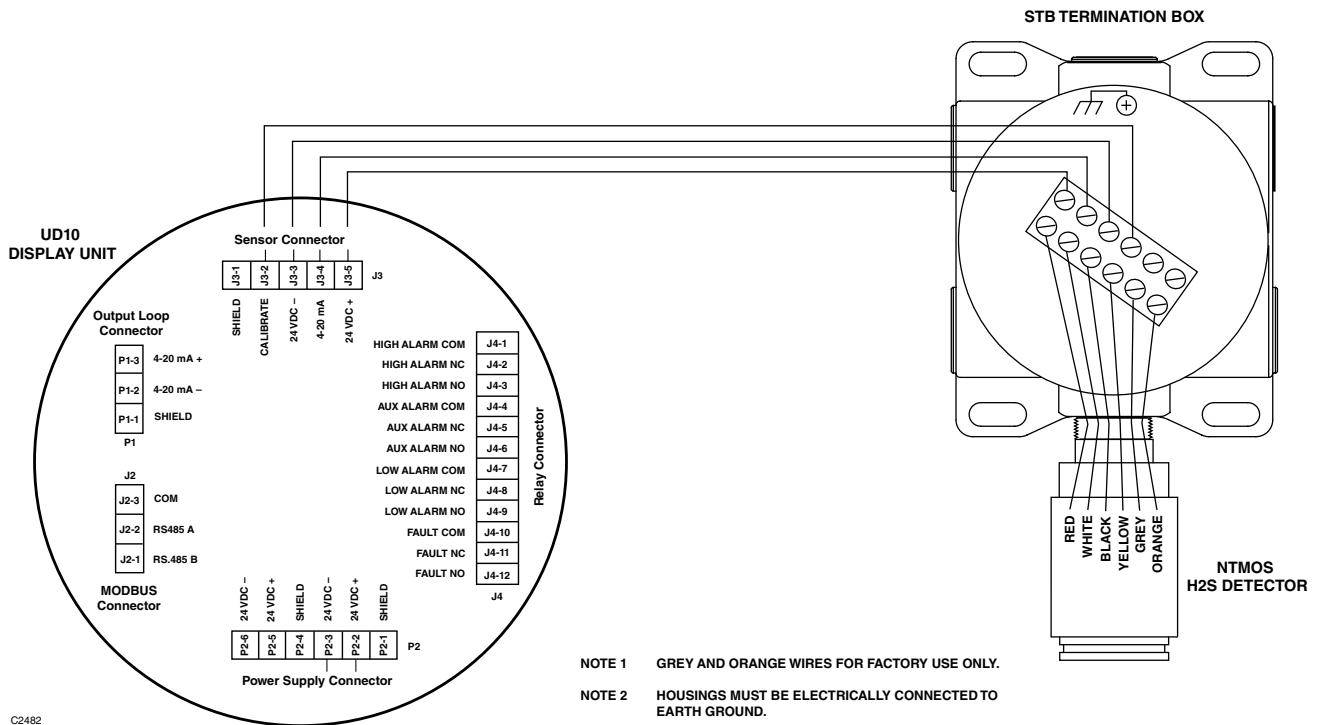

UD10 Wired to NTMOS Detector with STB Termination Box (Non-HART Applications Only)

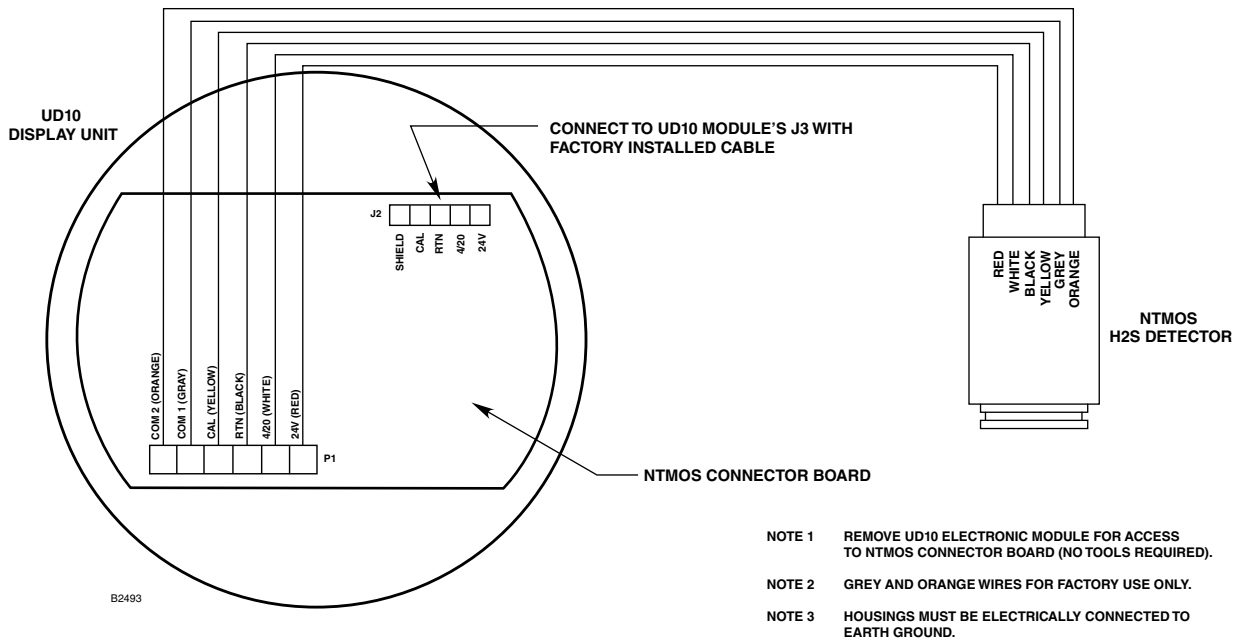

NTMOS Detector Wired Directly to UD10 via the NTMOS Connector Board
(NTMOS Connector Board is **Required** for HART Communication)

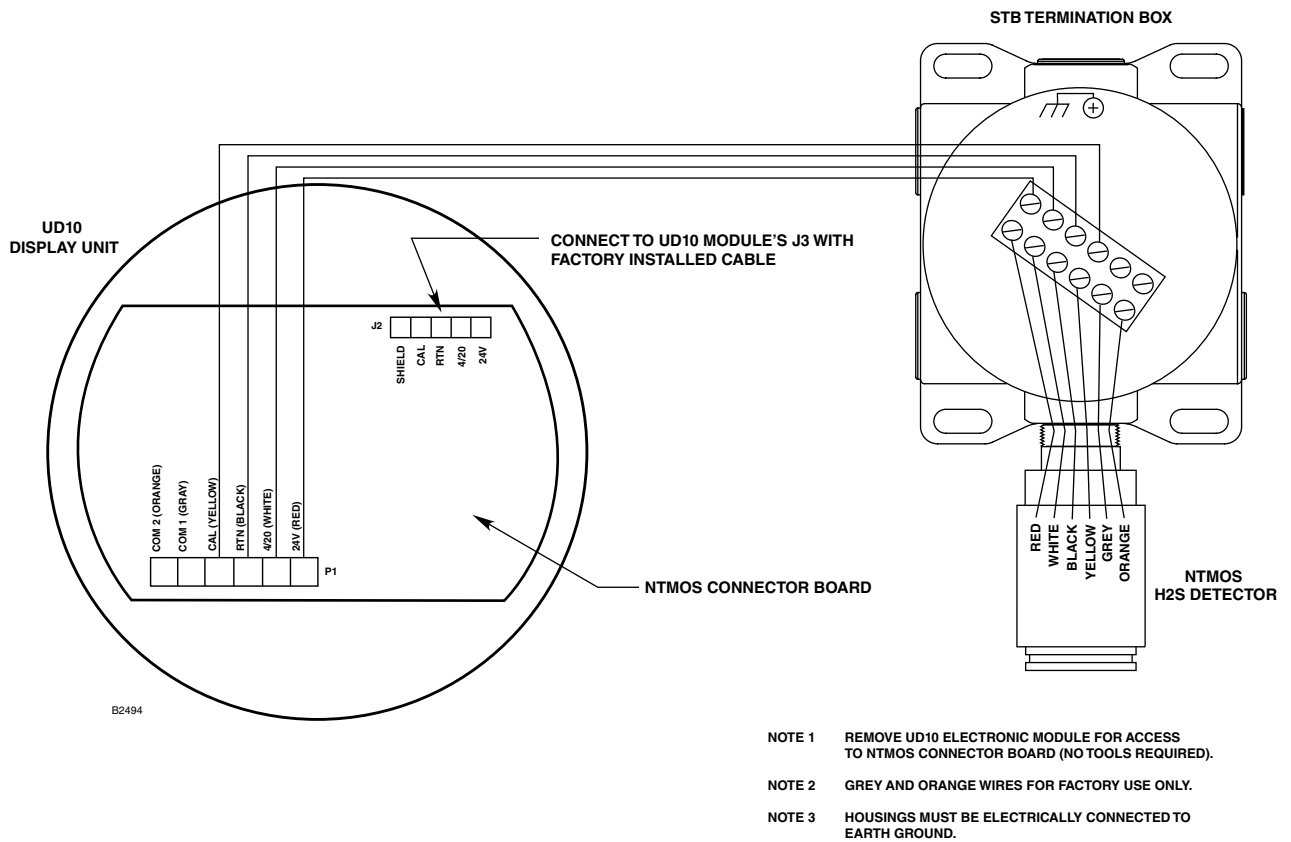

UD10 with NTMOS Connector Board Wired to NTMOS Detector with STB Termination Box
(NTMOS Connector Board is **Required** for HART Communication)

ORIENTATION

The UD10/NTMOS assembly must be mounted with the detector pointing down (see photo below).



CALIBRATION

Calibration Notes

The NTMOS detector must be calibrated using 50 ppm H₂S in air (never use H₂S in nitrogen).

Det-Tronics provides two acceptable sources of 50 ppm H₂S calibration gas for use with NTMOS detectors.

WARNING

The use of any other H₂S calibration mixture will produce inaccurate calibration results, possibly resulting in a dangerous condition if the detector under-reports the level of H₂S.

1. 50 ppm Ampoule Calibration Kit (p/n 007098-005) with 50 ppm ampoules (p/n 225741-001)

To operate the Ampoule Calibrator:

- Remove the cover and insert a 50 ppm H₂S ampoule into the ampoule holder inside the calibrator. Tighten the thumb screw until snug.
- Place the cover back on the calibrator and connect it snugly to the NTMOS detector.
- Tighten the thumb screw until the ampoule breaks.
- Rotate the mixing fan by slowly turning the mixing fan lever.

2. Humidification Tube Calibration Kit (p/n 010272-001) with bottled 50 ppm H₂S in air (p/n 227117-014). For complete information regarding use of the Humidification Tube Calibration Kit, refer to instruction manual number 95-8648.

NOTE

*When calibrating with bottled 50 ppm H₂S in air, the humidification tube **must** be used.*

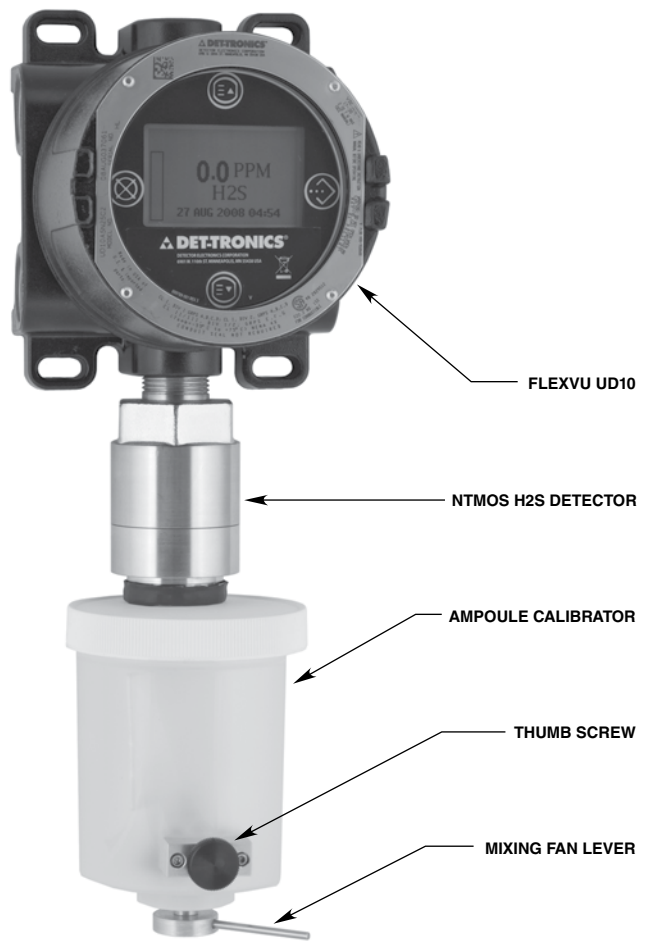

Ampoule Calibrator Attached to NTMOS Detector



Humidification Tube Calibration Kit Attached to NTMOS Detector

5. Apply calibration gas to the detector.
6. With 50 ppm H₂S applied to the detector, the UD10 display will continue to show “Waiting for Span” while the span calibration is being performed.
7. When the UD10 Display shows “Remove Cal Gas” the calibration is complete. Remove calibration gas from the detector.
8. When the gas level falls below the lowest alarm setpoint, the UD10 automatically exits the Calibrate mode and returns to normal operating mode.

MENU STRUCTURE

UD10 with NTMOS H₂S Detector

Refer to the following menu when using the UD10's LCD display and internal magnetic switches.

When connecting a HART Communicator to the UD10's 4-20 mA output, refer to the “UD10 HART Handheld” menu in Appendix F.

MENU HELP

*Status menus only allow the user to view the data.
The Setup menus allow the user to both view and edit the data.*

Calibration Procedure

To calibrate the NTMOS detector with the FlexVu UD10 Display:

1. Touch the magnet to the ENTER/SELECT button to display the Main Menu. Follow the illustration below to navigate to the “Calibrate” menu.

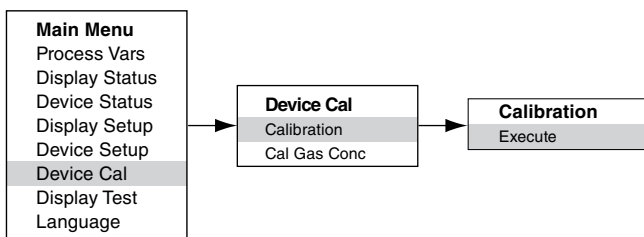

2. Activate “Execute” (Enter/Select) to begin the zero calibration.
3. The UD10 will display “Waiting for Zero” on the main display screen.
4. When zero calibration is complete (approximately one minute), the UD10 will display “Waiting for Span” on the main display screen.

| UD10 mA Output During Calibration (UD10 with NTMOS) | | |
|--|---------------|----------------|
| UD10 Display Reading | Standard Mode | Replicate Mode |
| Waiting for Zero | 3.8 | 2.2 |
| Waiting for Gas | 3.8 | 3.8 |
| Waiting for Span | 3.8 | 3.8 |
| Remove Cal Gas | 3.8 | 3.8 |
| Back to Normal | 4.0 | 4.0 |

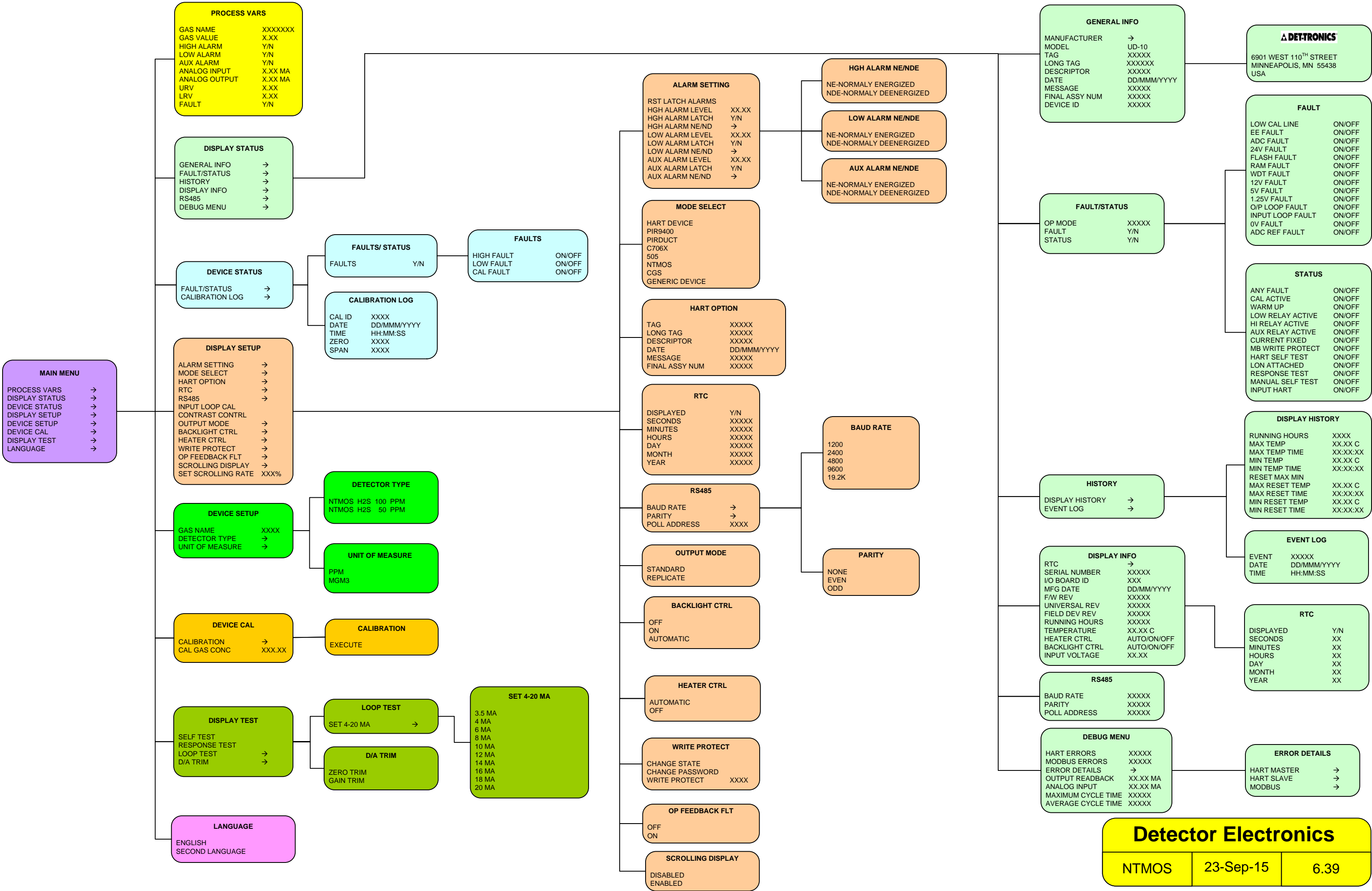

MAIN MENU

- PROCESS VARS →
- DISPLAY STATUS →
- DEVICE STATUS →
- DISPLAY SETUP →
- DEVICE SETUP →
- DEVICE CAL →
- DISPLAY TEST →
- LANGUAGE →

PROCESS VARS

| | |
|---------------|---------|
| GAS NAME | XXXXXXX |
| GAS VALUE | X.XX |
| HIGH ALARM | Y/N |
| LOW ALARM | Y/N |
| AUX ALARM | Y/N |
| ANALOG INPUT | X.XX MA |
| ANALOG OUTPUT | X.XX MA |
| URV | X.XX |
| LRV | X.XX |
| FAULT | Y/N |

DISPLAY STATUS

- GENERAL INFO →
- FAULT/STATUS →
- HISTORY →
- DISPLAY INFO →
- RS485 →
- DEBUG MENU →

DEVICE STATUS

- FAULT/STATUS →
- CALIBRATION LOG →

DISPLAY SETUP

- ALARM SETTING →
- MODE SELECT →
- HART OPTION →
- RTC →
- RS485 →
- INPUT LOOP CAL
- CONTRAST CONTRL
- OUTPUT MODE →
- BACKLIGHT CTRL →
- HEATER CTRL →
- WRITE PROTECT →
- OP FEEDBACK FLT →
- SCROLLING DISPLAY →
- SET SCROLLING RATE XXX%

DEVICE SETUP

- GAS NAME XXXX
- DETECTOR TYPE →
- UNIT OF MEASURE →

DEVICE CAL

- CALIBRATION →
- CAL GAS CONC XXX.XX

DISPLAY TEST

- SELF TEST
- RESPONSE TEST
- LOOP TEST →
- D/A TRIM →

LANGUAGE

- ENGLISH
- SECOND LANGUAGE

FAULTS/ STATUS

- FAULTS Y/N

CALIBRATION LOG

| | |
|--------|-------------|
| CAL ID | XXXX |
| DATE | DD/MMM/YYYY |
| TIME | HH:MM:SS |
| ZERO | XXXX |
| SPAN | XXXX |

DETECTOR TYPE

- NTMOS H2S 100 PPM
- NTMOS H2S 50 PPM

UNIT OF MEASURE

- PPM
- MGM3

CALIBRATION

- EXECUTE

LOOP TEST

- SET 4-20 MA →

D/A TRIM

- ZERO TRIM
- GAIN TRIM

FAULTS

| | |
|------------|--------|
| HIGH FAULT | ON/OFF |
| LOW FAULT | ON/OFF |
| CAL FAULT | ON/OFF |

SET 4-20 MA

- 3.5 MA
- 4 MA
- 6 MA
- 8 MA
- 10 MA
- 12 MA
- 14 MA
- 16 MA
- 18 MA
- 20 MA

ALARM SETTING

| | |
|------------------|-------|
| RST LATCH ALARMS | |
| HGH ALARM LEVEL | XX.XX |
| HGH ALARM LATCH | Y/N |
| HGH ALARM NE/ND | → |
| LOW ALARM LEVEL | XX.XX |
| LOW ALARM LATCH | Y/N |
| LOW ALARM NE/ND | → |
| AUX ALARM LEVEL | XX.XX |
| AUX ALARM LATCH | Y/N |
| AUX ALARM NE/ND | → |

MODE SELECT

- HART DEVICE
- PIR9400
- PIRDUCT
- C706X
- 505
- NTMOS
- CGS
- GENERIC DEVICE

HART OPTION

| | |
|----------------|-------------|
| TAG | XXXXX |
| LONG TAG | XXXXX |
| DESCRIPTOR | XXXXX |
| DATE | DD/MMM/YYYY |
| MESSAGE | XXXXX |
| FINAL ASSY NUM | XXXXX |

RTC

| | |
|-----------|-------|
| DISPLAYED | Y/N |
| SECONDS | XXXXX |
| MINUTES | XXXXX |
| HOURS | XXXXX |
| DAY | XXXXX |
| MONTH | XXXXX |
| YEAR | XXXXX |

RS485

- BAUD RATE →
- PARITY →
- POLL ADDRESS XXXX

OUTPUT MODE

- STANDARD
- REPLICATE

BACKLIGHT CTRL

- OFF
- ON
- AUTOMATIC

HEATER CTRL

- AUTOMATIC
- OFF

WRITE PROTECT

- CHANGE STATE
- CHANGE PASSWORD
- WRITE PROTECT XXXX

OP FEEDBACK FLT

- OFF
- ON

SCROLLING DISPLAY

- DISABLED
- ENABLED

HGH ALARM NE/NDE

- NE-NORMALY ENERGIZED
- NDE-NORMALY DEENERGIZED

LOW ALARM NE/NDE

- NE-NORMALY ENERGIZED
- NDE-NORMALY DEENERGIZED

AUX ALARM NE/NDE

- NE-NORMALY ENERGIZED
- NDE-NORMALY DEENERGIZED

BAUD RATE

- 1200
- 2400
- 4800
- 9600
- 19.2K

PARITY

- NONE
- EVEN
- ODD

GENERAL INFO

| | |
|----------------|-------------|
| MANUFACTURER | → |
| MODEL | UD-10 |
| TAG | XXXXX |
| LONG TAG | XXXXXX |
| DESCRIPTOR | XXXXX |
| DATE | DD/MMM/YYYY |
| MESSAGE | XXXXX |
| FINAL ASSY NUM | XXXXX |
| DEVICE ID | XXXXX |

DET-TRONICS

6901 WEST 110TH STREET
MINNEAPOLIS, MN 55438
USA

FAULT/STATUS

| | |
|---------|-------|
| OP MODE | XXXXX |
| FAULT | Y/N |
| STATUS | Y/N |

FAULT

| | |
|------------------|--------|
| LOW CAL LINE | ON/OFF |
| EE FAULT | ON/OFF |
| ADC FAULT | ON/OFF |
| 24V FAULT | ON/OFF |
| FLASH FAULT | ON/OFF |
| RAM FAULT | ON/OFF |
| WDT FAULT | ON/OFF |
| 12V FAULT | ON/OFF |
| 5V FAULT | ON/OFF |
| 1.25V FAULT | ON/OFF |
| O/P LOOP FAULT | ON/OFF |
| INPUT LOOP FAULT | ON/OFF |
| 0V FAULT | ON/OFF |
| ADC REF FAULT | ON/OFF |

STATUS

| | |
|------------------|--------|
| ANY FAULT | ON/OFF |
| CAL ACTIVE | ON/OFF |
| WARM UP | ON/OFF |
| LOW RELAY ACTIVE | ON/OFF |
| HI RELAY ACTIVE | ON/OFF |
| AUX RELAY ACTIVE | ON/OFF |
| CURRENT FIXED | ON/OFF |
| MB WRITE PROTECT | ON/OFF |
| HART SELF TEST | ON/OFF |
| LON ATTACHED | ON/OFF |
| RESPONSE TEST | ON/OFF |
| MANUAL SELF TEST | ON/OFF |
| INPUT HART | ON/OFF |

DISPLAY HISTORY

| | |
|----------------|----------|
| RUNNING HOURS | XXXX |
| MAX TEMP | XX.XX C |
| MAX TEMP TIME | XX:XX:XX |
| MIN TEMP | XX.XX C |
| MIN TEMP TIME | XX:XX:XX |
| RESET MAX MIN | |
| MAX RESET TEMP | XX.XX C |
| MAX RESET TIME | XX:XX:XX |
| MIN RESET TEMP | XX.XX C |
| MIN RESET TIME | XX:XX:XX |

HISTORY

- DISPLAY HISTORY →
- EVENT LOG →

EVENT LOG

| | |
|-------|-------------|
| EVENT | XXXXX |
| DATE | DD/MMM/YYYY |
| TIME | HH:MM:SS |

DISPLAY INFO

- RTC →
- SERIAL NUMBER XXXXX
- I/O BOARD ID XXX
- MFG DATE DD/MM/YYYY
- F/W REV XXXXX
- UNIVERSAL REV XXXXX
- FIELD DEV REV XXXXX
- RUNNING HOURS XXXXX
- TEMPERATURE XX.XX C
- HEATER CTRL AUTO/ON/OFF
- BACKLIGHT CTRL AUTO/ON/OFF
- INPUT VOLTAGE XX.XX

RTC

| | |
|-----------|-----|
| DISPLAYED | Y/N |
| SECONDS | XX |
| MINUTES | XX |
| HOURS | XX |
| DAY | XX |
| MONTH | XX |
| YEAR | XX |

RS485

- BAUD RATE XXXXX
- PARITY XXXXX
- POLL ADDRESS XXXXX

DEBUG MENU

- HART ERRORS XXXXX
- MODBUS ERRORS XXXXX
- ERROR DETAILS →
- OUTPUT READBACK XX.XX MA
- ANALOG INPUT XX.XX MA
- MAXIMUM CYCLE TIME XXXXX
- AVERAGE CYCLE TIME XXXXX

ERROR DETAILS

- HART MASTER →
- HART SLAVE →
- MODBUS →

Detector Electronics

| | | |
|-------|-----------|------|
| NTMOS | 23-Sep-15 | 6.39 |
|-------|-----------|------|

APPENDIX L

UD10 with C706X TOXIC GAS SENSOR

NOTE

For complete information regarding the C7064E H2S Gas Sensor, refer to instruction manual 95-8396.
For the C7067E Chlorine Gas Sensor, refer to instruction manual 95-8439.

WIRING

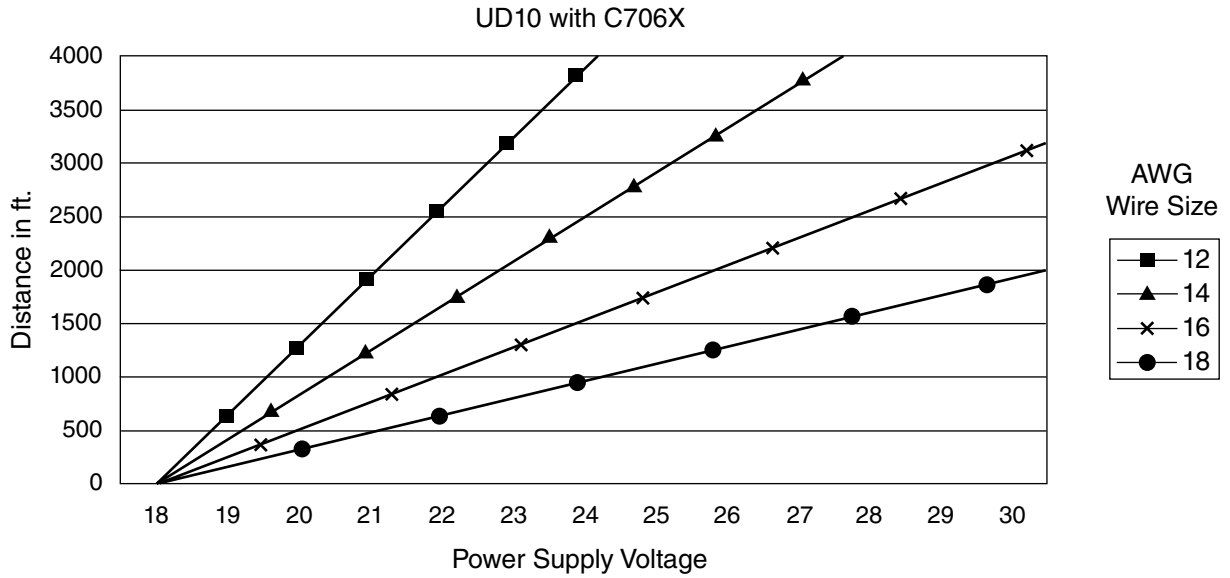

Notes: Maximum recommended cable length from power source to UD10 is 2000 feet.
Maximum recommended cable length from UD10 to sensor/STB termination box is 2000 feet.

Model C7065E oxygen sensor is not supported.

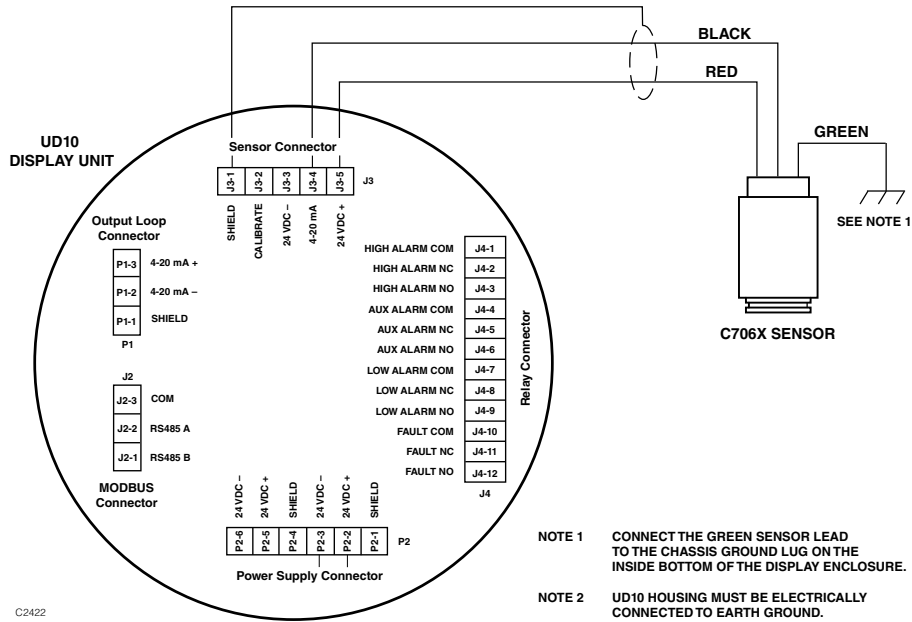

C706X Sensor Wired Directly to UD10

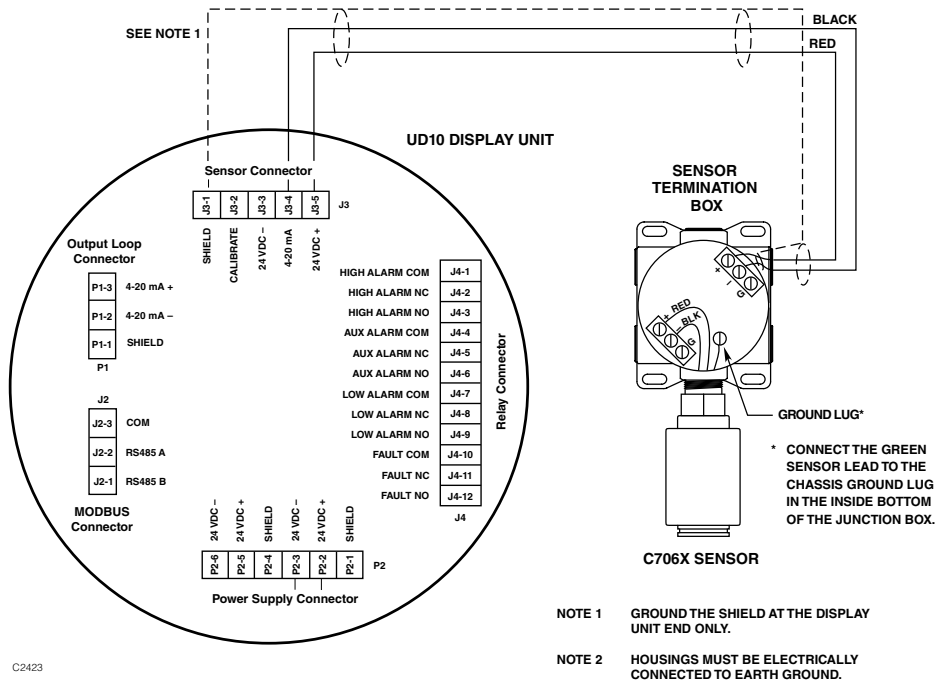

UD10 Wired to C706X Sensor with STB Termination Box

INSTALLATION

WIRING REQUIREMENTS

The simplest installation involves installing the sensor into one of the UD10 openings and connecting the wiring directly to the UD10. If the installation requires separation of the C706X sensor and the UD10 Display, the sensor can be connected to a STB sensor termination box, and the C706X/STB combination wired to the UD10. In this case, shielded cable is recommended to help protect against interference caused by extraneous electrical "noise." In applications where the cable is installed in conduit, the conduit should not be used for wiring to other electrical equipment whenever possible. If other equipment power wiring is run in the same conduit, the cabling **must** be shielded. The maximum allowable distance between the C706X sensor and UD10 Display Unit is limited by the resistance of the cabling used.

INSTALLATION AND WIRING PROCEDURE

1. Determine the best mounting locations for the detectors.
2. Install the C706X sensor within the proper opening in the UD10 or STB junction box. Mount the UD10/C706X with the sensor oriented vertically and the opening pointing down. The UD10 should be electrically connected to earth ground.

NOTE

The electrochemical sensor cell does not need to be installed within the C706X housing while installing and wiring the detector/junction box. It is recommended to keep the sensor in the manufacturer's sealed shipping bag in a cool storage environment until actual power-up and calibration commissioning is performed. This will ensure that the sensor will provide maximum longevity.

3. Terminate all three C706X conductors at the proper terminals. Refer to the appropriate illustration for details.
4. Double check that all wiring is the proper size and type and has been installed correctly. Check operating voltage at the C706X sensor and the UD10 Display Unit.

NOTE

Do not apply power to the system with the junction box cover removed unless the area has been de-classified.

5. Proceed with startup and calibration.

CALIBRATION

To initiate calibration of the C706X sensor from the UD10 Display:

1. Using the magnet to activate the switches on the UD10 display, navigate to the "Calibrate" menu.

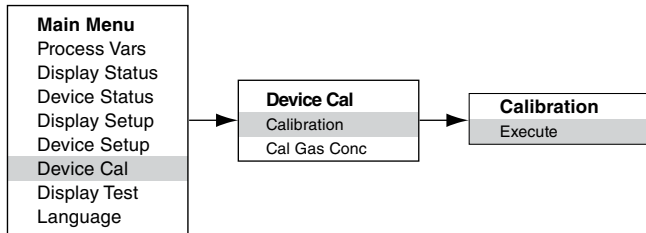

2. Activate "Execute" (Enter/Select) to start calibration.
3. The UD10 will display "Waiting for Zero" on the main display screen as it performs zero calibration.
4. When zero calibration is complete, the UD10 will display "Waiting for Gas" on the screen.
5. Apply calibration gas to the sensor.
6. The UD10 will display "Waiting for Span" on the screen while the span calibration is being performed.
7. When the UD10 displays "Remove Cal Gas" on the screen, remove the calibration gas from the sensor.
8. When calibration is complete, "Remove Cal Gas" is no longer displayed on the screen and the UD10 automatically returns to the normal operating mode.

MENU STRUCTURE

UD10 with C706X Series Sensor

Refer to the following menu when using the UD10's LCD display and internal magnetic switches.

When connecting a HART Communicator to the UD10's 4-20 mA output, refer to the "UD10 HART Handheld" menu in Appendix F.

MENU HELP

*Status menus only allow the user to view the data.
The Setup menus allow the user to both view and edit the data.*

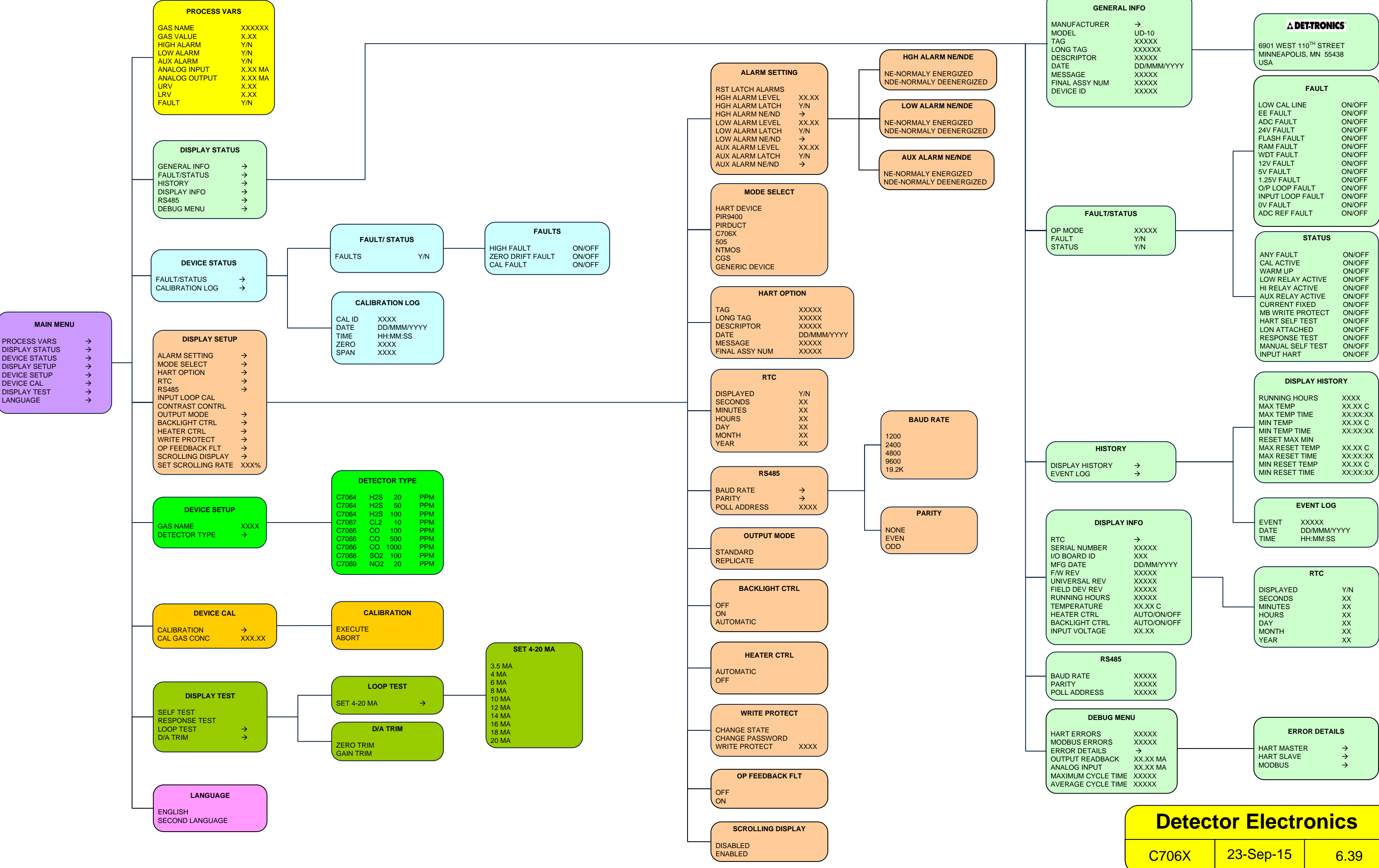

APPENDIX M

UD10 with MODEL CGS COMBUSTIBLE GAS SENSOR

WIRING

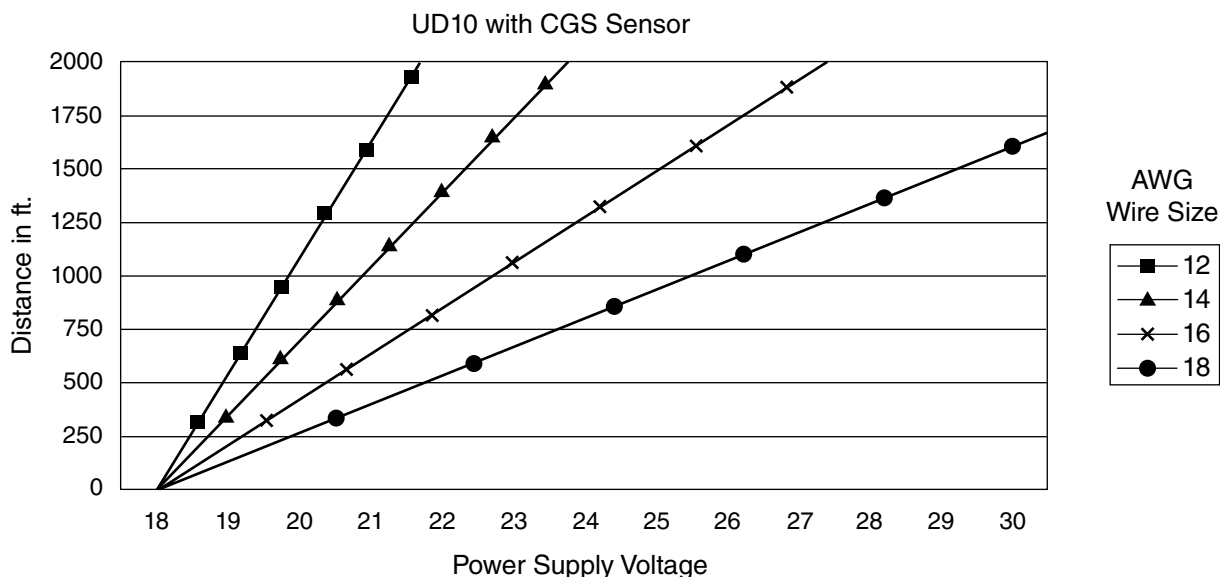

Notes: Maximum recommended cable length from power source to UD10 is 2000 feet.
Maximum recommended cable length from UD10 to CGS sensor is 500 feet
(using 16 AWG, 1.5 mm² cable minimum).

IMPORTANT NOTES

NOTE

The UD10 with CGS Interface option and CGS sensor is certified as a "Gas Detector" and performance approved to standards FM6310/6320, ATEX 60079-29-1, and IEC 60079-29-1.

NOTE

Only Constant Current type CGS sensors may be used with the UD10.

NOTE

When the auxiliary relay is set for latching and the gas level goes above the auxiliary alarm threshold, the 4-20 mA output will latch to the highest gas level detected until it is reset. When CGS mode is selected, the default setting for the auxiliary relay is a threshold of 90% full scale, with latching output.

⚠ CAUTION

The sintered metal flame arrestor is an integral part of the combustible gas sensor. DO NOT operate the gas detector if the flame arrestor is damaged or missing, since the exposed element is a potential ignition source.

⚠ CAUTION

Silicone based lubricants must never be used on or near the CGS sensor, since this can result in irreversible damage to the sensing element.

⚠ CAUTION

When used as a stand alone device, the high alarm must always be programmed for latching operation. When used in conjunction with a Control Unit and configured for a non-latching high alarm, the control unit must always latch and require a deliberate manual action to clear a high gas alarm.

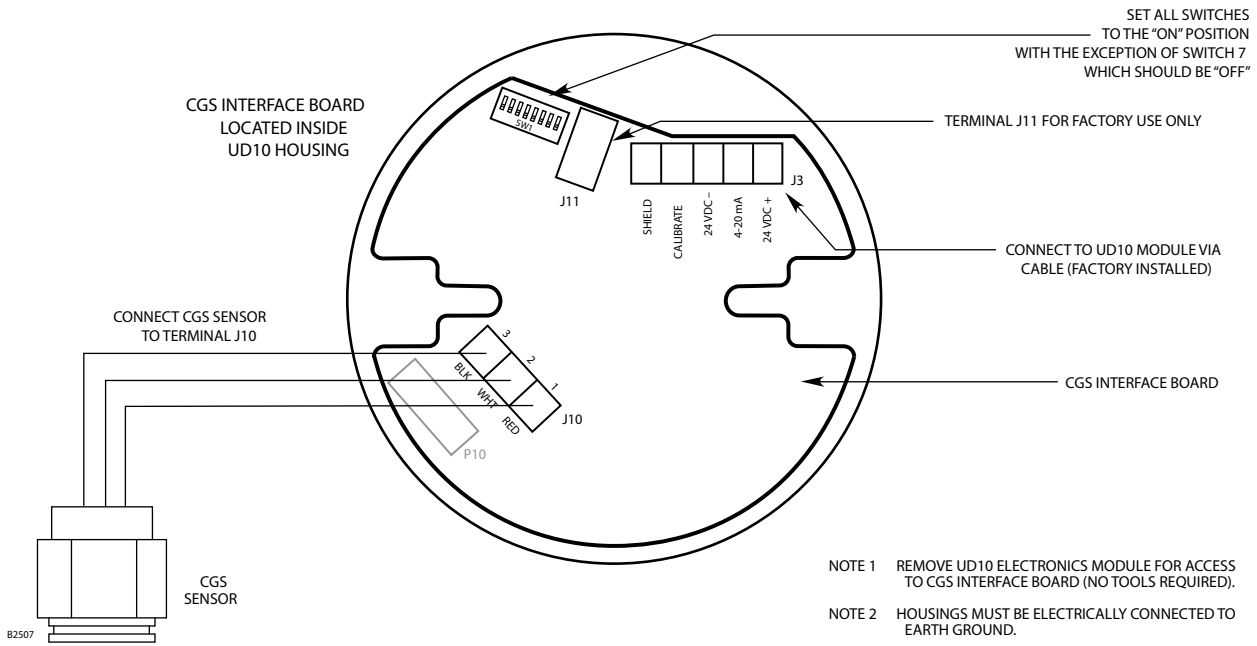

CGS Sensor Wired Directly to UD10

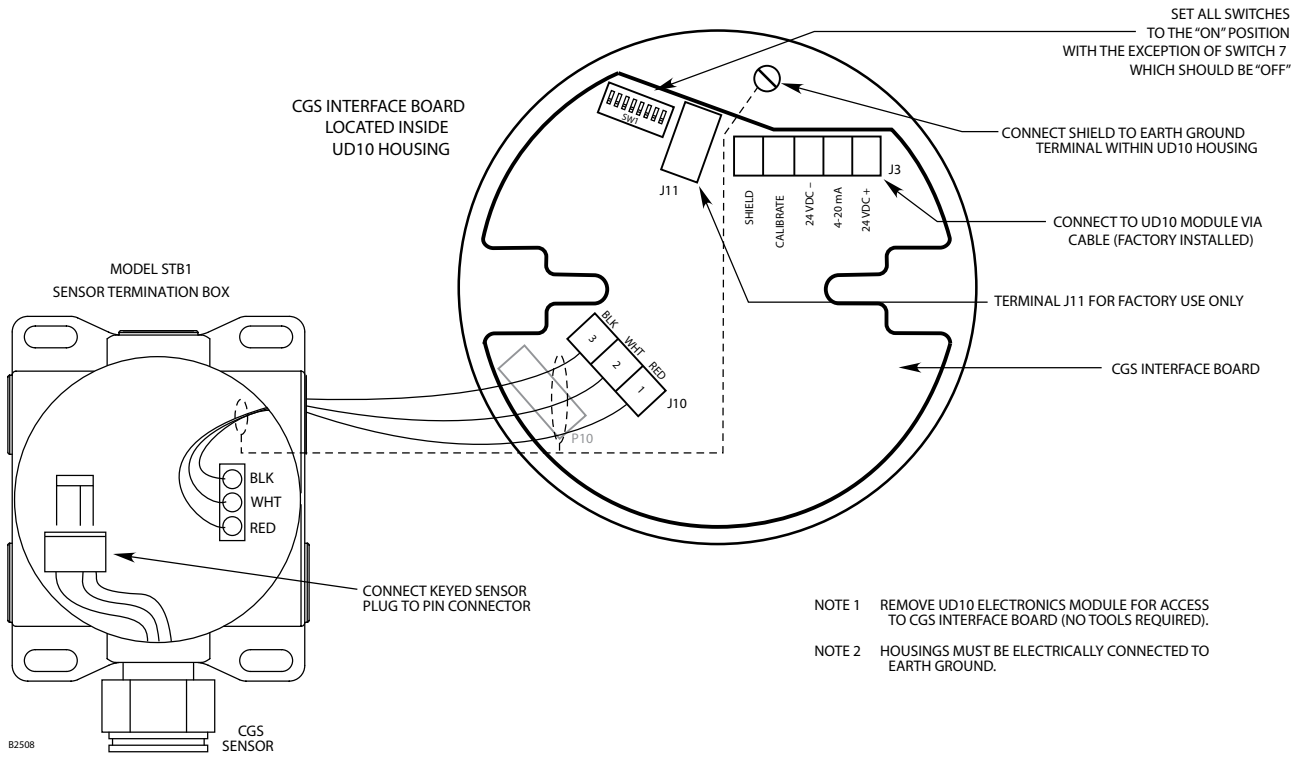

UD10 Wired to CGS Sensor with STB Termination Box

INSTALLATION

WIRING REQUIREMENTS

The simplest installation involves installing the sensor into one of the UD10 openings and connecting the wiring directly to the CGS interface board.

Sensor Separation

If the installation requires separation of the CGS sensor and the UD10 Display, the sensor can be connected to a model STB1 sensor termination box, and the CGS/STB combination wired to the UD10.

In this case, shielded cable is recommended to help protect against interference caused by extraneous electrical “noise.”

In applications where the cable is installed in conduit, the conduit should not be used for wiring to other electrical equipment whenever possible. If other equipment power wiring is run in the same conduit, the cabling **must** be shielded.

The maximum allowable distance between the CGS sensor and UD10 Display Unit is 500 feet, with connecting cable 16 AWG, 1.5 mm² minimum.

INSTALLATION AND WIRING PROCEDURE

1. Determine the best mounting locations for the detectors.
2. Install the CGS sensor within the proper opening in the UD10 or STB junction box. Mount the device with the sensor oriented vertically and the opening pointing down. All junction boxes should be electrically connected to earth ground.
3. Terminate all wiring at the proper terminals. Refer to the appropriate illustration for details.
4. Double check that all wiring is the proper size and type and has been installed correctly. Check for correct operating voltage at the device.

NOTE

Do not apply power to the system with the junction box cover removed unless the area has been de-classified.

5. Proceed with startup and calibration.

CALIBRATION

NOTE

For maximum calibration accuracy, allow a new sensor to operate under power for several hours (minimum one hour) to ensure a stable output before performing calibration. For the highest degree of accuracy, perform a second calibration after 24 hours.

To initiate calibration of the CGS sensor from the UD10 Display:

1. Using the magnet to activate the switches on the UD10 display, navigate to the “Calibrate” menu.

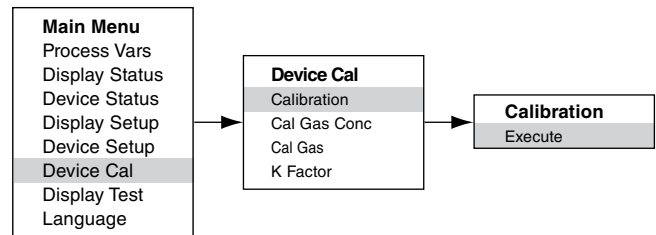

2. Activate “Execute” (Enter/Select) to start calibration.
3. The UD10 will display “Waiting for Zero” on the main display screen as it performs zero calibration.
4. When zero calibration is complete, the UD10 will display “Waiting for Gas” on the screen.
5. Apply calibration gas to the sensor.
6. The UD10 will display “Waiting for Span” on the screen while the span calibration is being performed.
7. When the UD10 shows “Remove Cal Gas” on the screen, remove the calibration gas from the sensor.
8. The UD10 automatically exits the Calibrate mode and returns to normal operating mode upon completion of a successful calibration.

| UD10 mA Output During Calibration (UD10 with CGS) | | |
|--|---------------|----------------|
| UD10 Display Reading | Standard Mode | Replicate Mode |
| Apply Zero Gas | 3.8 | 2.2 |
| Waiting for Gas | 3.8 | 3.8 |
| Waiting for Span | 3.8 | 3.8 |
| Remove Cal Gas | 3.8 | 3.8 |
| Back to Normal | 4.0 | 4.0 |

Determining Sensor Life Remaining

At the time of calibration, the UD10 logs the sensor mV signal. This value can be used for determining the approximate sensor life remaining.

To view all the recorded mV signal values for the sensor, from the Main Menu, navigate to:

Device Status > Calibration Log > Span.

To view the mV signal from the most recent calibration only, from the Main Menu, navigate to:

Device Status > Device Info > Response.

A typical new sensor reads between 45 and 55 mV.

- At 21-55 mV, "Cal OK" is recorded in the Cal Log, along with the Span value.
- At 15-20 mV, "Cal OK" is recorded in the Cal Log, along with the Span value. In addition, "Weak Sensor" is shown on the UD10 display for about 20 seconds. After 20 seconds, the "Weak Sensor" message is no longer seen, but a "Weak Sensor" status is recorded (Device Status > Fault/Status > Status).
- At 14 mV or less, "Weak Sensor" is shown on the UD10 display for about 20 seconds, then a Cal Fault is shown. The Cal Log shows "Cal Fail" with a Span value of 0.00 mV.

K FACTOR

If the system will be detecting a gas/vapor other than the gas used in the actual calibration process, a conversion K-Factor must be used. The K-Factor can be entered prior to calibration by navigating to the "Device Option" menu, then selecting "K-Factor." Enter the desired K-Factor and activate the "Enter" button. The new K-Factor will be applied when the sensor is calibrated.

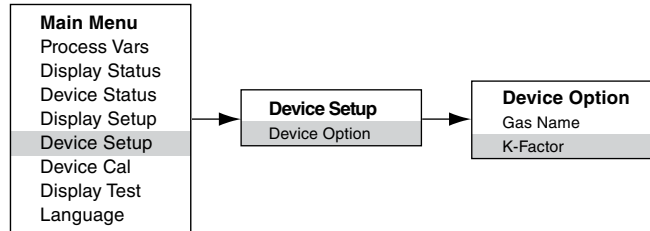

The UD10 communicates the K-Factor to the CGS Interface Board during the calibration process, where the proper correction is made to ensure accurate calibration.

The actual effect of the K-Factor can be observed as the span portion of the calibration is completed. For example, suppose a K-Factor of 0.865 has been programmed. When calibration is performed, the UD10 will display 50% as span is accepted. It will then apply the K-Factor, and the displayed value will change to 43.3% LFL.

For additional information regarding K-Factors, including a list of K-Factors for many common gases, refer to technical bulletin number 76-1017.

MENU STRUCTURE

UD10 with CGS Series Sensor

Refer to the following menu when using the UD10's LCD display and internal magnetic switches.

When connecting a HART Communicator to the UD10's 4-20 mA output, refer to the "UD10 HART Handheld" menu in Appendix F.

MENU HELP

*Status menus only allow the user to view the data.
The Setup menus allow the user to both view and edit the data.*

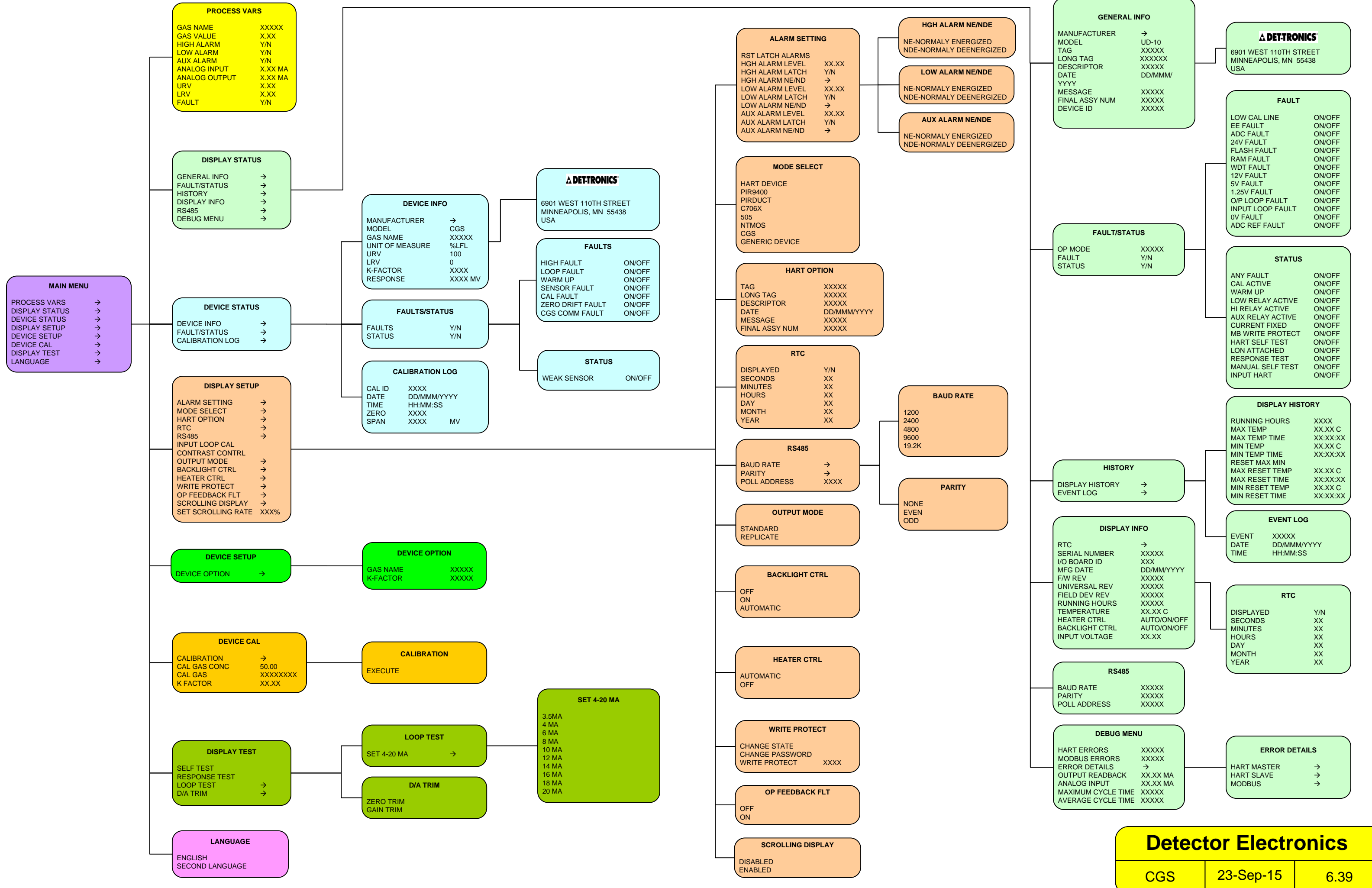

MAIN MENU

- PROCESS VARS →
- DISPLAY STATUS →
- DEVICE STATUS →
- DISPLAY SETUP →
- DEVICE SETUP →
- DEVICE CAL →
- DISPLAY TEST →
- LANGUAGE →

PROCESS VARS

| | |
|---------------|---------|
| GAS NAME | XXXXX |
| GAS VALUE | X.XX |
| HIGH ALARM | Y/N |
| LOW ALARM | Y/N |
| AUX ALARM | Y/N |
| ANALOG INPUT | X.XX MA |
| ANALOG OUTPUT | X.XX MA |
| URV | X.XX |
| LRV | X.XX |
| FAULT | Y/N |

DISPLAY STATUS

- GENERAL INFO →
- FAULT/STATUS →
- HISTORY →
- DISPLAY INFO →
- RS485 →
- DEBUG MENU →

DEVICE STATUS

- DEVICE INFO →
- FAULT/STATUS →
- CALIBRATION LOG →

DISPLAY SETUP

- ALARM SETTING →
- MODE SELECT →
- HART OPTION →
- RTC →
- RS485 →
- INPUT LOOP CAL →
- CONTRAST CONTRL →
- OUTPUT MODE →
- BACKLIGHT CTRL →
- HEATER CTRL →
- WRITE PROTECT →
- OP FEEDBACK FLT →
- SCROLLING DISPLAY →
- SET SCROLLING RATE XXX%

DEVICE SETUP

- DEVICE OPTION →

DEVICE CAL

- CALIBRATION →
- CAL GAS CONC 50.00
- CAL GAS XXXXXXXX
- K FACTOR XX.XX

DISPLAY TEST

- SELF TEST
- RESPONSE TEST
- LOOP TEST →
- D/A TRIM →

LANGUAGE

- ENGLISH
- SECOND LANGUAGE

DEVICE INFO

- MANUFACTURER →
- MODEL CGS
- GAS NAME XXXXX
- UNIT OF MEASURE %LFL
- URV 100
- LRV 0
- K-FACTOR XXXX
- RESPONSE XXXX MV

FAULTS/STATUS

- FAULTS Y/N
- STATUS Y/N

CALIBRATION LOG

| | | |
|--------|-------------|----|
| CAL ID | XXXX | |
| DATE | DD/MMM/YYYY | |
| TIME | HH:MM:SS | |
| ZERO | XXXX | MV |
| SPAN | XXXX | MV |

DEVICE OPTION

| | |
|----------|-------|
| GAS NAME | XXXXX |
| K-FACTOR | XXXXX |

CALIBRATION

- EXECUTE

LOOP TEST

- SET 4-20 MA →

D/A TRIM

- ZERO TRIM
- GAIN TRIM

DET-TRONICS

6901 WEST 110TH STREET
MINNEAPOLIS, MN 55438
USA

FAULTS

| | |
|------------------|--------|
| HIGH FAULT | ON/OFF |
| LOOP FAULT | ON/OFF |
| WARM UP | ON/OFF |
| SENSOR FAULT | ON/OFF |
| CAL FAULT | ON/OFF |
| ZERO DRIFT FAULT | ON/OFF |
| CGS COMM FAULT | ON/OFF |

STATUS

- WEAK SENSOR ON/OFF

SET 4-20 MA

- 3.5MA
- 4 MA
- 6 MA
- 8 MA
- 10 MA
- 12 MA
- 14 MA
- 16 MA
- 18 MA
- 20 MA

ALARM SETTING

| | |
|------------------|-------|
| RST LATCH ALARMS | |
| HGH ALARM LEVEL | XX.XX |
| HGH ALARM LATCH | Y/N |
| HGH ALARM NE/ND | → |
| LOW ALARM LEVEL | XX.XX |
| LOW ALARM LATCH | Y/N |
| LOW ALARM NE/ND | → |
| AUX ALARM LEVEL | XX.XX |
| AUX ALARM LATCH | Y/N |
| AUX ALARM NE/ND | → |

HGH ALARM NE/NDE

- NE-NORMALY ENERGIZED
- NDE-NORMALY DEENERGIZED

LOW ALARM NE/NDE

- NE-NORMALY ENERGIZED
- NDE-NORMALY DEENERGIZED

AUX ALARM NE/NDE

- NE-NORMALY ENERGIZED
- NDE-NORMALY DEENERGIZED

MODE SELECT

- HART DEVICE
- PIR9400
- PIRDUCT
- C706X
- 505
- NTMOS
- CGS
- GENERIC DEVICE

HART OPTION

| | |
|----------------|-------------|
| TAG | XXXXX |
| LONG TAG | XXXXX |
| DESCRIPTOR | XXXXX |
| DATE | DD/MMM/YYYY |
| MESSAGE | XXXXX |
| FINAL ASSY NUM | XXXXX |

RTC

| | |
|-----------|-----|
| DISPLAYED | Y/N |
| SECONDS | XX |
| MINUTES | XX |
| HOURS | XX |
| DAY | XX |
| MONTH | XX |
| YEAR | XX |

BAUD RATE

- 1200
- 2400
- 4800
- 9600
- 19.2K

RS485

- BAUD RATE →
- PARITY →
- POLL ADDRESS XXXX

PARITY

- NONE
- EVEN
- ODD

OUTPUT MODE

- STANDARD
- REPLICATE

BACKLIGHT CTRL

- OFF
- ON
- AUTOMATIC

HEATER CTRL

- AUTOMATIC
- OFF

WRITE PROTECT

- CHANGE STATE
- CHANGE PASSWORD
- WRITE PROTECT XXXX

OP FEEDBACK FLT

- OFF
- ON

SCROLLING DISPLAY

- DISABLED
- ENABLED

GENERAL INFO

| | | |
|----------------|---------|------|
| MANUFACTURER | → | |
| MODEL | UD-10 | |
| TAG | XXXXX | |
| LONG TAG | XXXXXX | |
| DESCRIPTOR | XXXXX | |
| DATE | DD/MMM/ | YYYY |
| MESSAGE | XXXXX | |
| FINAL ASSY NUM | XXXXX | |
| DEVICE ID | XXXXX | |

DET-TRONICS

6901 WEST 110TH STREET
MINNEAPOLIS, MN 55438
USA

FAULT

| | |
|------------------|--------|
| LOW CAL LINE | ON/OFF |
| EE FAULT | ON/OFF |
| ADC FAULT | ON/OFF |
| 24V FAULT | ON/OFF |
| FLASH FAULT | ON/OFF |
| RAM FAULT | ON/OFF |
| WDT FAULT | ON/OFF |
| 12V FAULT | ON/OFF |
| 5V FAULT | ON/OFF |
| 1.25V FAULT | ON/OFF |
| O/P LOOP FAULT | ON/OFF |
| INPUT LOOP FAULT | ON/OFF |
| 0V FAULT | ON/OFF |
| ADC REF FAULT | ON/OFF |

STATUS

| | |
|------------------|--------|
| ANY FAULT | ON/OFF |
| CAL ACTIVE | ON/OFF |
| WARM UP | ON/OFF |
| LOW RELAY ACTIVE | ON/OFF |
| HI RELAY ACTIVE | ON/OFF |
| AUX RELAY ACTIVE | ON/OFF |
| CURRENT FIXED | ON/OFF |
| MB WRITE PROTECT | ON/OFF |
| HART SELF TEST | ON/OFF |
| LON ATTACHED | ON/OFF |
| RESPONSE TEST | ON/OFF |
| MANUAL SELF TEST | ON/OFF |
| INPUT HART | ON/OFF |

DISPLAY HISTORY

| | |
|----------------|----------|
| RUNNING HOURS | XXXX |
| MAX TEMP | XX.XX C |
| MAX TEMP TIME | XX:XX:XX |
| MIN TEMP | XX.XX C |
| MIN TEMP TIME | XX:XX:XX |
| RESET MAX MIN | |
| MAX RESET TEMP | XX.XX C |
| MAX RESET TIME | XX:XX:XX |
| MIN RESET TEMP | XX.XX C |
| MIN RESET TIME | XX:XX:XX |

FAULT/STATUS

| | |
|---------|-------|
| OP MODE | XXXXX |
| FAULT | Y/N |
| STATUS | Y/N |

HISTORY

- DISPLAY HISTORY →
- EVENT LOG →

DISPLAY INFO

| | | |
|----------------|-------------|--|
| RTC | → | |
| SERIAL NUMBER | XXXXX | |
| I/O BOARD ID | XXX | |
| MFG DATE | DD/MM/YYYY | |
| F/W REV | XXXXX | |
| UNIVERSAL REV | XXXXX | |
| FIELD DEV REV | XXXXX | |
| RUNNING HOURS | XXXXX | |
| TEMPERATURE | XX.XX C | |
| HEATER CTRL | AUTO/ON/OFF | |
| BACKLIGHT CTRL | AUTO/ON/OFF | |
| INPUT VOLTAGE | XX.XX | |

EVENT LOG

| | |
|-------|-------------|
| EVENT | XXXXX |
| DATE | DD/MMM/YYYY |
| TIME | HH:MM:SS |

RTC

| | |
|-----------|-----|
| DISPLAYED | Y/N |
| SECONDS | XX |
| MINUTES | XX |
| HOURS | XX |
| DAY | XX |
| MONTH | XX |
| YEAR | XX |

RS485

| | |
|--------------|-------|
| BAUD RATE | XXXXX |
| PARITY | XXXXX |
| POLL ADDRESS | XXXXX |

DEBUG MENU

| | |
|--------------------|----------|
| HART ERRORS | XXXXX |
| MODBUS ERRORS | XXXXX |
| ERROR DETAILS | → |
| OUTPUT READBACK | XX.XX MA |
| ANALOG INPUT | XX.XX MA |
| MAXIMUM CYCLE TIME | XXXXX |
| AVERAGE CYCLE TIME | XXXXX |

ERROR DETAILS

- HART MASTER →
- HART SLAVE →
- MODBUS →

APPENDIX N

UD10 with MODEL 505 TRANSMITTER / CGS SENSOR

NOTE

For complete information regarding the Model 505 Transmitter, refer to instruction manual 95-8472.

WIRING

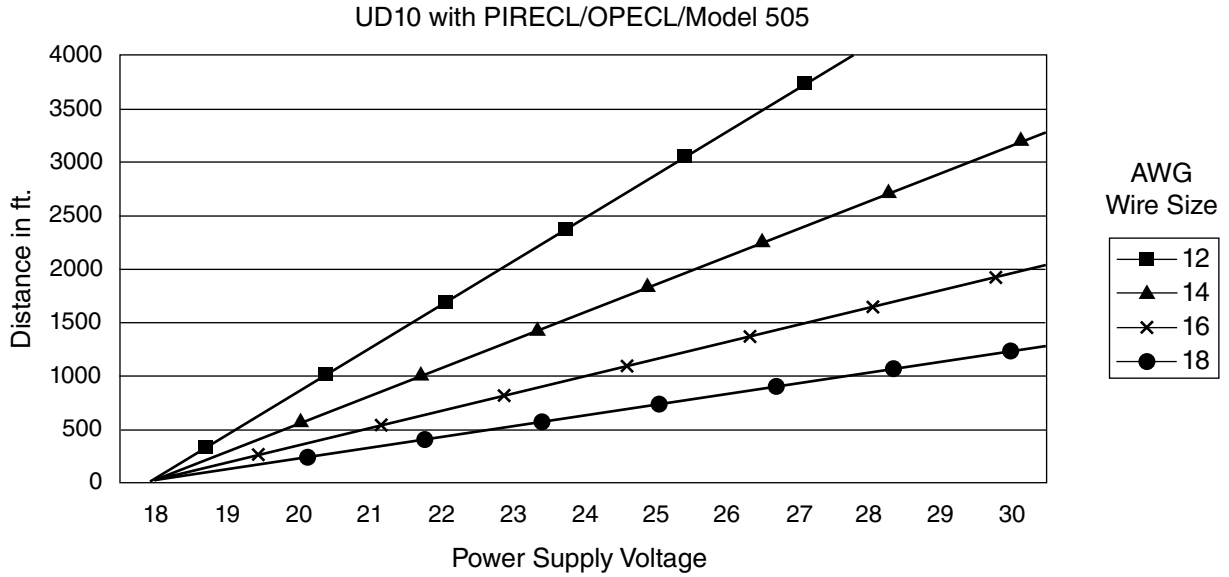

Notes: Maximum recommended cable length from power source to UD10 is 2000 feet.
 Maximum recommended cable length from UD10 to sensor/STB termination box is 2000 feet.

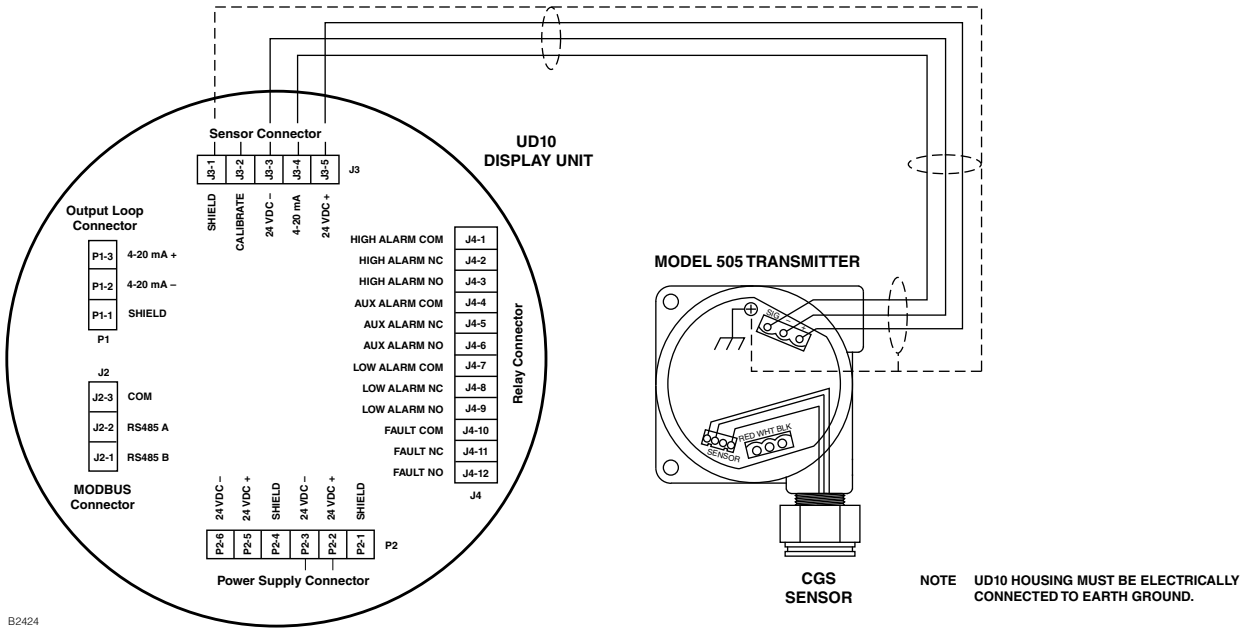

UD10 Wired to Model 505 Transmitter/CGS Sensor

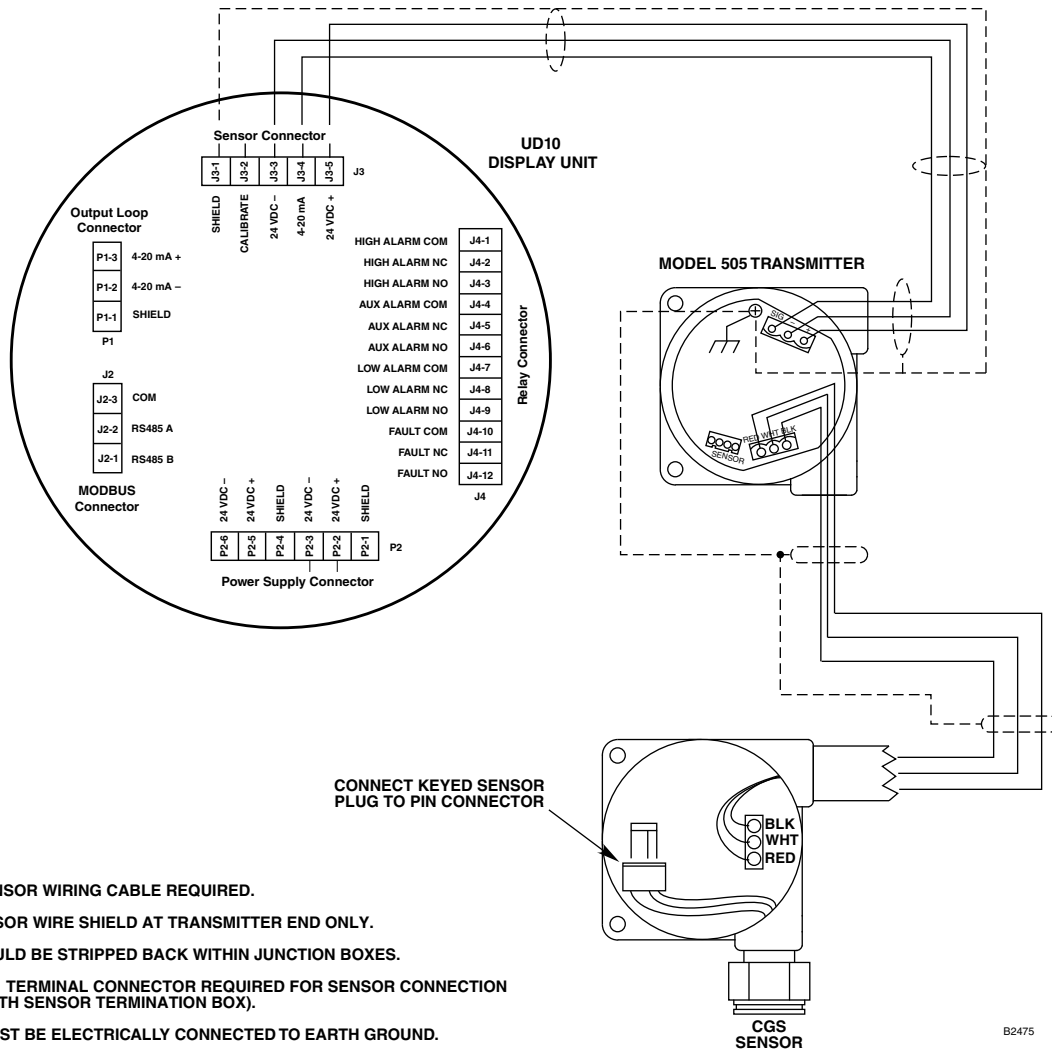

- NOTES**
1. SHIELDED SENSOR WIRING CABLE REQUIRED.
 2. GROUND SENSOR WIRE SHIELD AT TRANSMITTER END ONLY.
 3. SHIELDS SHOULD BE STRIPPED BACK WITHIN JUNCTION BOXES.
 4. P/N 102883-001 TERMINAL CONNECTOR REQUIRED FOR SENSOR CONNECTION (PROVIDED WITH SENSOR TERMINATION BOX).
 5. HOUSINGS MUST BE ELECTRICALLY CONNECTED TO EARTH GROUND.

UD10 Wired to Model 505 Transmitter/CGS Sensor Using Sensor Separation Termination Box

INSTALLATION

Refer to the Model 505 instruction manual number 95-8472 for complete information regarding proper installation of the Model 505 with combustible gas sensor.

ORIENTATION

The Model 505/CGS must be mounted with the CGS sensor opening pointing down.

CALIBRATION

NOTE

For maximum calibration accuracy, allow a new sensor to operate under power for several hours (minimum one hour) to ensure a stable output before performing calibration. For the highest degree of accuracy, perform a second calibration after 24 hours.

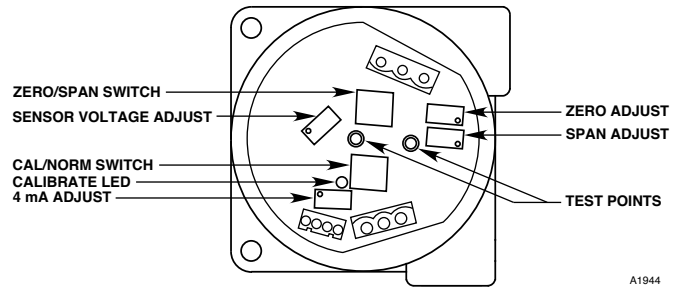

A1944

Model 505

The Model 505/CGS must be calibrated when the system is commissioned as well as when the CGS sensor is replaced. Calibration is performed at the Model 505 using the following procedure. Calibration at the UD10 is not supported.

| WARNING | | |
|--|--|--|
| <i>Before removing the junction box cover, verify that no dangerous levels of gas are present.</i> | | |
| Step | Switch Position | Operator Action |
| 1 | CAL/NORM switch in the CAL position. | <ol style="list-style-type: none"> 1. LED turns on. 2. Connect a digital voltmeter to the transmitter test jacks. 3. Set the meter range to 2 Vdc. |
| 2 | ZERO/SPAN switch in the ZERO position. | <ol style="list-style-type: none"> 1. Adjust the ZERO potentiometer to read 0.000 Vdc on the voltmeter. See Note 3 below. |
| 3 | ZERO/SPAN switch in the SPAN position. | <ol style="list-style-type: none"> 1. Adjust the 4 mA potentiometer to read 0.167 Vdc on the voltmeter. 2. Apply the 50% LFL calibration gas to the sensor. When the output has stabilized, adjust the SPAN potentiometer for a reading of 0.500 on the voltmeter. |
| 4 | ZERO/SPAN switch in the ZERO position. | <ol style="list-style-type: none"> 1. Sensitivity test. The meter must read greater than 0.015 Vdc. See Note 4 below. 2. Remove the calibration gas. 3. When the meter reads 0.002 Vdc or less, remove the test probes. |
| 5 | CAL/NORM switch in NORM position. | <ol style="list-style-type: none"> 1. The LED turns off. 2. The calibration is complete. 3. Replace the junction box cover. |

NOTES:

1. When the CAL/NORM switch is in the CAL position, the yellow LED turns on and the 4-20 mA output signal goes to 3.4 mA.
2. The voltmeter must be suitable for use in a hazardous location.
3. If the possibility of background gases exists, purge the sensor with clean air prior to the zero adjustment to assure accurate calibration.
4. A typical sensitivity reading with 50% LFL gas applied to the sensor is 35 to 50 millivolts for a new sensor. Sensor replacement is recommended when the sensitivity reading is less than 15 millivolts.
5. If a dust cover or splash shield is used, inspect it to be sure that it is not dirty or plugged. A plugged dust cover can restrict the flow of gas to the sensing element, seriously reducing its effectiveness. For optimum performance, sensor covers/filters should be replaced frequently to ensure that they are not degraded or plugged.

MENU STRUCTURE

UD10 with Model 505 / CGS Sensor

Refer to the following menu when using the UD10's LCD display and internal magnetic switches.

When connecting a HART Communicator to the UD10's 4-20 mA output, refer to the "UD10 HART Handheld" menu in Appendix F.

MENU HELP

Status menus only allow the user to view the data.

The Setup menus allow the user to both view and edit the data.

MAIN MENU

- PROCESS VARS →
- DISPLAY STATUS →
- DEVICE STATUS →
- DISPLAY SETUP →
- DEVICE CAL →
- DISPLAY TEST →
- LANGUAGE →

PROCESS VARS

| | |
|---------------|---------|
| GAS NAME | XXXXXXX |
| GAS VALUE | X.XX |
| HIGH ALARM | Y/N |
| LOW ALARM | Y/N |
| AUX ALARM | Y/N |
| ANALOG INPUT | X.XX MA |
| ANALOG OUTPUT | X.XX MA |
| URV | X.XX |
| LRV | X.XX |
| FAULT | Y/N |

DISPLAY STATUS

- GENERAL INFO →
- FAULT/STATUS →
- HISTORY →
- DISPLAY INFO →
- RS485 →
- DEBUG MENU →

DEVICE STATUS

- FAULT/STATUS →

DISPLAY SETUP

- ALARM SETTING →
- MODE SELECT →
- HART OPTION →
- RTC →
- RS485 →
- INPUT LOOP CAL →
- CONTRAST CONTRL →
- OUTPUT MODE →
- BACKLIGHT CTRL →
- HEATER CTRL →
- WRITE PROTECT →
- OP FEEDBACK FLT →
- SCROLLING DISPLAY →
- SET SCROLLING RATE XXX%

DEVICE SETUP

- GAS NAME XXXX
- DETECTOR TYPE →

FAULTS/ STATUS

- FAULTS Y/N

FAULTS

- HIGH FAULT ON/OFF
- LOW FAULT ON/OFF

CALIBRATION LOG

| | |
|--------|-------------|
| CAL ID | XXXX |
| DATE | DD/MMM/YYYY |
| TIME | HH:MM:SS |
| ZERO | XXXX |
| SPAN | XXXX |

DETECTOR TYPE

505 CH4 100 %LFL

DEVICE CAL

- CALIBRATION →
- CAL GAS CONC XXX.XX

CALIBRATION

- EXECUTE
- ABORT

DISPLAY TEST

- SELF TEST
- RESPONSE TEST
- LOOP TEST →
- D/A TRIM →

LOOP TEST

- SET 4-20 MA →

D/A TRIM

- ZERO TRIM
- GAIN TRIM

SET 4-20 MA

- 3.5 MA
- 4 MA
- 6 MA
- 8 MA
- 10 MA
- 12 MA
- 14 MA
- 16 MA
- 18 MA
- 20 MA

LANGUAGE

- ENGLISH
- SECOND LANGUAGE

ALARM SETTING

| | |
|------------------|-------|
| RST LATCH ALARMS | XX.XX |
| HGH ALARM LEVEL | Y/N |
| HGH ALARM NE/ND | → |
| LOW ALARM LEVEL | XX.XX |
| LOW ALARM LATCH | Y/N |
| LOW ALARM NE/ND | → |
| AUX ALARM LEVEL | XX.XX |
| AUX ALARM LATCH | Y/N |
| AUX ALARM NE/ND | → |

HGH ALARM NE/NDE

- NE-NORMALY ENERGIZED
- NDE-NORMALY DEENERGIZED

LOW ALARM NE/NDE

- NE-NORMALY ENERGIZED
- NDE-NORMALY DEENERGIZED

AUX ALARM NE/NDE

- NE-NORMALY ENERGIZED
- NDE-NORMALY DEENERGIZED

MODE SELECT

- HART DEVICE
- PIR9400
- PIRDUCT
- C706X
- 505
- NTMOS
- CGS
- GENERIC DEVICE

HART OPTION

| | |
|----------------|-------------|
| TAG | XXXXX |
| LONG TAG | XXXXX |
| DESCRIPTOR | XXXXX |
| DATE | DD/MMM/YYYY |
| MESSAGE | XXXXX |
| FINAL ASSY NUM | XXXXX |

RTC

| | |
|-----------|-----|
| DISPLAYED | Y/N |
| SECONDS | XX |
| MINUTES | XX |
| HOURS | XX |
| DAY | XX |
| MONTH | XX |
| YEAR | XX |

RS485

- BAUD RATE →
- PARITY →
- POLL ADDRESS XXXX

BAUD RATE

- 1200
- 2400
- 4800
- 9600
- 19.2K

PARITY

- NONE
- EVEN
- ODD

OUTPUT MODE

- STANDARD
- REPLICATE

BACKLIGHT CTRL

- OFF
- ON
- AUTOMATIC

HEATER CTRL

- AUTOMATIC
- OFF

WRITE PROTECT

- CHANGE STATE
- CHANGE PASSWORD
- WRITE PROTECT XXXX

OP FEEDBACK FLT

- OFF
- ON

SCROLLING DISPLAY

- DISABLED
- ENABLED

GENERAL INFO

| | |
|----------------|-------------|
| MANUFACTURER | → |
| MODEL | UD-10 |
| TAG | XXXXXX |
| LONG TAG | XXXXXX |
| DESCRIPTOR | XXXXX |
| DATE | DD/MMM/YYYY |
| MESSAGE | XXXXX |
| FINAL ASSY NUM | XXXXX |
| DEVICE ID | XXXXX |

DET-TRONICS

6901 WEST 110TH STREET
MINNEAPOLIS, MN 55438
USA

FAULT/STATUS

- OP MODE XXXXX
- FAULT Y/N
- STATUS Y/N

FAULT

| | |
|------------------|--------|
| LOW CAL LINE | ON/OFF |
| EE FAULT | ON/OFF |
| ADC FAULT | ON/OFF |
| 24V FAULT | ON/OFF |
| FLASH FAULT | ON/OFF |
| RAM FAULT | ON/OFF |
| WDT FAULT | ON/OFF |
| 12V FAULT | ON/OFF |
| 5V FAULT | ON/OFF |
| 1.25V FAULT | ON/OFF |
| O/P LOOP FAULT | ON/OFF |
| INPUT LOOP FAULT | ON/OFF |
| 0V FAULT | ON/OFF |
| ADC REF FAULT | ON/OFF |

STATUS

| | |
|------------------|--------|
| ANY FAULT | ON/OFF |
| CAL ACTIVE | ON/OFF |
| WARM UP | ON/OFF |
| LOW RELAY ACTIVE | ON/OFF |
| HI RELAY ACTIVE | ON/OFF |
| AUX RELAY ACTIVE | ON/OFF |
| CURRENT FIXED | ON/OFF |
| MB WRITE PROTECT | ON/OFF |
| HART SELF TEST | ON/OFF |
| LON ATTACHED | ON/OFF |
| RESPONSE TEST | ON/OFF |
| MANUAL SELF TEST | ON/OFF |
| INPUT HART | ON/OFF |

HISTORY

- DISPLAY HISTORY →
- EVENT LOG →

DISPLAY HISTORY

| | |
|----------------|----------|
| RUNNING HOURS | XXXX |
| MAX TEMP | XX.XX C |
| MAX TEMP TIME | XX:XX:XX |
| MIN TEMP | XX.XX C |
| MIN TEMP TIME | XX:XX:XX |
| RESET MAX MIN | |
| MAX RESET TEMP | XX.XX C |
| MAX RESET TIME | XX:XX:XX |
| MIN RESET TEMP | XX.XX C |
| MIN RESET TIME | XX:XX:XX |

EVENT LOG

| | |
|-------|-------------|
| EVENT | XXXXX |
| DATE | DD/MMM/YYYY |
| TIME | HH:MM:SS |

DISPLAY INFO

| | |
|----------------|-------------|
| RTC | → |
| SERIAL NUMBER | XXXXX |
| I/O BOARD ID | XXX |
| MFG DATE | DD/MM/YYYY |
| F/W REV | XXXXX |
| UNIVERSAL REV | XXXXX |
| FIELD DEV REV | XXXXX |
| RUNNING HOURS | XXXXX |
| TEMPERATURE | XX.XX C |
| HEATER CTRL | AUTO/ON/OFF |
| BACKLIGHT CTRL | AUTO/ON/OFF |
| INPUT VOLTAGE | XX.XX |

RTC

| | |
|-----------|-----|
| DISPLAYED | Y/N |
| SECONDS | XX |
| MINUTES | XX |
| HOURS | XX |
| DAY | XX |
| MONTH | XX |
| YEAR | XX |

RS485

- BAUD RATE XXXXX
- PARITY XXXXX
- POLL ADDRESS XXXXX

DEBUG MENU

| | |
|--------------------|----------|
| HART ERRORS | XXXXX |
| MODBUS ERRORS | XXXXX |
| ERROR DETAILS | → |
| OUTPUT READBACK | XX.XX MA |
| ANALOG INPUT | XX.XX MA |
| MAXIMUM CYCLE TIME | XXXXX |
| AVERAGE CYCLE TIME | XXXXX |

ERROR DETAILS

- HART MASTER →
- HART SLAVE →
- MODBUS →

Detector Electronics

| | | |
|-----|-----------|------|
| 505 | 23-Sep-15 | 6.39 |
|-----|-----------|------|

APPENDIX O

UD10 with GENERIC 4-20 mA SENSORS

NOTE

For complete information regarding installation, wiring, and calibration of the sensor, refer to the instruction manual provided by the sensor manufacturer.

OPERATION

The UD10 can be used with generic sensors that generate a calibrated linear 4-20 mA signal, with or without HART. The UD10 allows the operator to select the upper and lower range values and unit of measurement. The UD10 then analyzes the 4-20 mA input signal from the sensor and displays the value with the designated measurement unit, and also controls the alarm outputs.

UPPER AND LOWER RANGE VALUES

The upper range value (URV) and lower range value (LRV) are selected using the magnetic tool and the UD10's menu system (Main Menu > Device Setup). The URV corresponds to the 20 mA signal while the LRV corresponds to 4 mA. The default values are 0 for the LRV and 100 for the URV. When the generic detector supports HART communication, the URV and LRV come from the attached detector.

MEASUREMENT UNIT TEXT

The operator can select the appropriate measurement unit from a pre-entered list: % (default), PPM, LFL, or PPB, or he can enter his own custom 4-character string. Measurement unit text is displayed on the main screen with the process variable. When the generic detector supports HART communication, the unit text comes from the attached detector.

LOW FAULT THRESHOLD

The operator can enter a low input fault threshold in the range of 0.5–4 mA (default is 3.5 mA). When the input signal is at or below this point, an "Out of Range Low Fault" is annunciated. This feature can be enabled/disabled as desired.

HIGH FAULT THRESHOLD

The operator can enter a high input fault threshold in the range of 20–27 mA (default is 21 mA). When the input signal is at or above this point, an "Out of Range High Fault" is annunciated. This feature can be enabled/disabled as desired.

ALARMS

The Low, High, and Auxiliary alarm levels are independently field adjustable. Alarm levels are set and displayed with the selected measurement units. All alarm levels must be within the LRV to URV range.

ALARM LATCHING

Latching or non-latching function is independently selectable for each alarm. The default setting is non-latching. Latched alarms can be reset with a "Reset Latched Alarms" command from the menu system or a power cycle.

SENSOR CALIBRATION

The UD10 does not support generic sensor calibration. Generic sensors must be pre-calibrated following the procedure described in the instruction manual provided by the sensor manufacturer.

4-20 MA OUTPUT READING

While in Generic mode, the UD10 displays values below the 4 mA level to allow the use of 0-20 mA sensors.

MENU STRUCTURE

UD10 with Generic 4-20 mA Sensors

Refer to the following menus when using the UD10's LCD display and internal magnetic switches. Two different menus are provided to accommodate sensors with or without HART communication.

When connecting a HART Communicator to the UD10's 4-20 mA output, refer to the "UD10 HART Handheld" menu in Appendix F.

MENU HELP

Status menus only allow the user to view the data. The Setup menus allow the user to both view and edit the data.

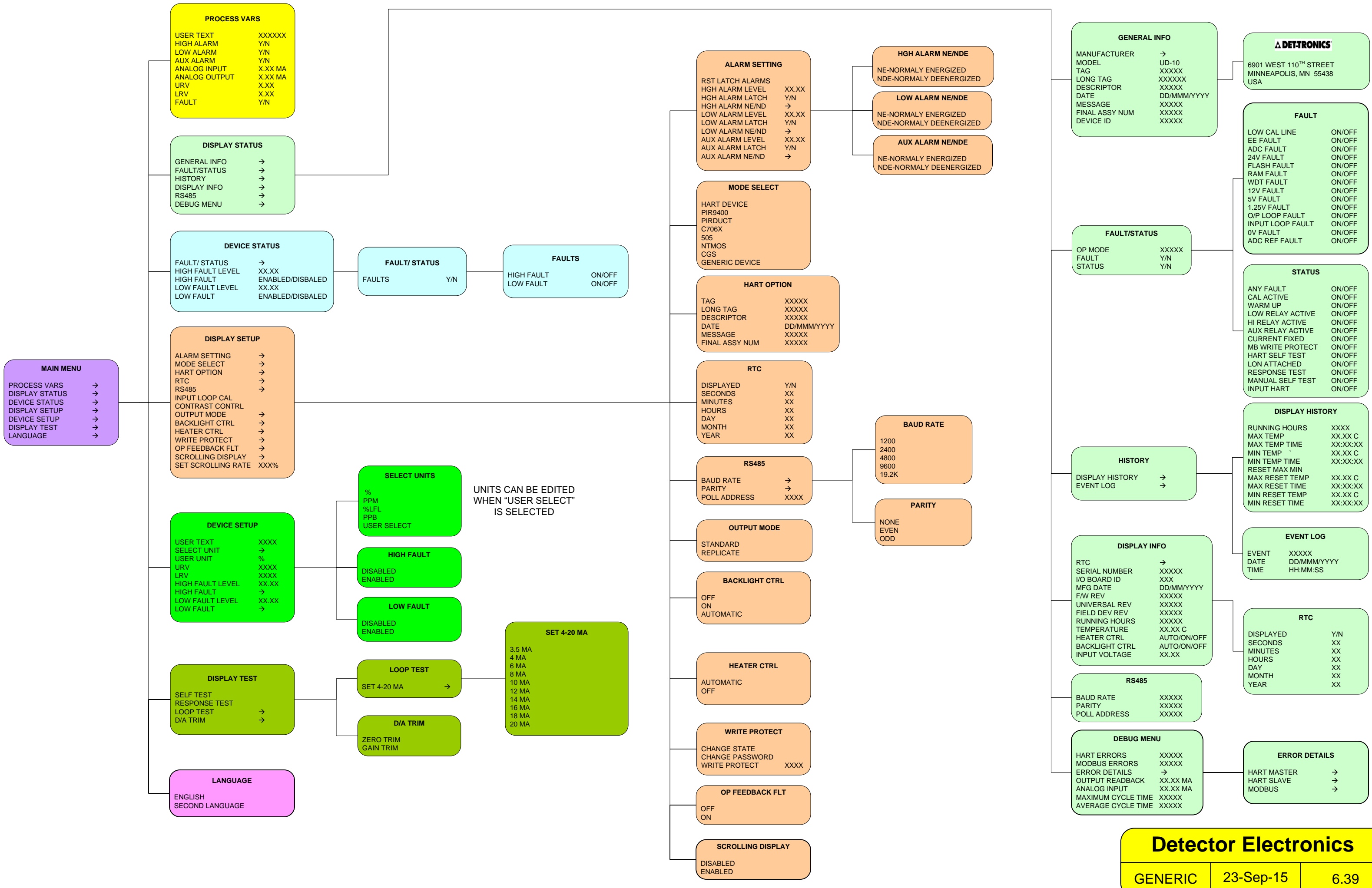

MAIN MENU

- PROCESS VARS →
- DISPLAY STATUS →
- DEVICE STATUS →
- DISPLAY SETUP →
- DEVICE SETUP →
- DISPLAY TEST →
- LANGUAGE →

PROCESS VARS

| | |
|---------------|---------|
| USER TEXT | XXXXXX |
| HIGH ALARM | Y/N |
| LOW ALARM | Y/N |
| AUX ALARM | Y/N |
| ANALOG INPUT | X.XX MA |
| ANALOG OUTPUT | X.XX MA |
| URV | X.XX |
| LRV | X.XX |
| FAULT | Y/N |

DISPLAY STATUS

- GENERAL INFO →
- FAULT/STATUS →
- HISTORY →
- DISPLAY INFO →
- RS485 →
- DEBUG MENU →

DEVICE STATUS

- FAULT/STATUS →
- HIGH FAULT LEVEL XX.XX
- HIGH FAULT ENABLED/DISBALED
- LOW FAULT LEVEL XX.XX
- LOW FAULT ENABLED/DISBALED

FAULT/STATUS

FAULTS Y/N

FAULTS

HIGH FAULT ON/OFF

LOW FAULT ON/OFF

DISPLAY SETUP

- ALARM SETTING →
- MODE SELECT →
- HART OPTION →
- RTC →
- RS485 →
- INPUT LOOP CAL
- CONTRAST CONTRL
- OUTPUT MODE →
- BACKLIGHT CTRL →
- HEATER CTRL →
- WRITE PROTECT →
- OP FEEDBACK FLT →
- SCROLLING DISPLAY →
- SET SCROLLING RATE XXX%

DEVICE SETUP

- USER TEXT XXXX
- SELECT UNIT →
- USER UNIT %
- URV XXXX
- LRV XXXX
- HIGH FAULT LEVEL XX.XX
- HIGH FAULT →
- LOW FAULT LEVEL XX.XX
- LOW FAULT →

SELECT UNITS

- %
- PPM
- %LFL
- PPB
- USER SELECT

HIGH FAULT

DISABLED

ENABLED

LOW FAULT

DISABLED

ENABLED

DISPLAY TEST

- SELF TEST
- RESPONSE TEST
- LOOP TEST →
- D/A TRIM →

LOOP TEST

SET 4-20 MA →

D/A TRIM

ZERO TRIM

GAIN TRIM

SET 4-20 MA

- 3.5 MA
- 4 MA
- 6 MA
- 8 MA
- 10 MA
- 12 MA
- 14 MA
- 16 MA
- 18 MA
- 20 MA

LANGUAGE

- ENGLISH
- SECOND LANGUAGE

ALARM SETTING

| | |
|------------------|-------|
| RST LATCH ALARMS | |
| HGH ALARM LEVEL | XX.XX |
| HGH ALARM LATCH | Y/N |
| HGH ALARM NE/ND | → |
| LOW ALARM LEVEL | XX.XX |
| LOW ALARM LATCH | Y/N |
| LOW ALARM NE/ND | → |
| AUX ALARM LEVEL | XX.XX |
| AUX ALARM LATCH | Y/N |
| AUX ALARM NE/ND | → |

HGH ALARM NE/NDE

NE-NORMALY ENERGIZED

NDE-NORMALY DEENERGIZED

LOW ALARM NE/NDE

NE-NORMALY ENERGIZED

NDE-NORMALY DEENERGIZED

AUX ALARM NE/NDE

NE-NORMALY ENERGIZED

NDE-NORMALY DEENERGIZED

MODE SELECT

HART DEVICE

PIR9400

PIRDUCT

C706X

505

NTMOS

CGS

GENERIC DEVICE

HART OPTION

| | |
|----------------|-------------|
| TAG | XXXXX |
| LONG TAG | XXXXX |
| DESCRIPTOR | XXXXX |
| DATE | DD/MMM/YYYY |
| MESSAGE | XXXXX |
| FINAL ASSY NUM | XXXXX |

RTC

| | |
|-----------|-----|
| DISPLAYED | Y/N |
| SECONDS | XX |
| MINUTES | XX |
| HOURS | XX |
| DAY | XX |
| MONTH | XX |
| YEAR | XX |

BAUD RATE

- 1200
- 2400
- 4800
- 9600
- 19.2K

PARITY

- NONE
- EVEN
- ODD

RS485

- BAUD RATE →
- PARITY →
- POLL ADDRESS XXXX

OUTPUT MODE

STANDARD

REPLICATE

BACKLIGHT CTRL

OFF

ON

AUTOMATIC

HEATER CTRL

AUTOMATIC

OFF

WRITE PROTECT

- CHANGE STATE
- CHANGE PASSWORD
- WRITE PROTECT XXXX

OP FEEDBACK FLT

OFF

ON

SCROLLING DISPLAY

DISABLED

ENABLED

GENERAL INFO

| | |
|----------------|-------------|
| MANUFACTURER | → |
| MODEL | UD-10 |
| TAG | XXXXX |
| LONG TAG | XXXXXX |
| DESCRIPTOR | XXXXX |
| DATE | DD/MMM/YYYY |
| MESSAGE | XXXXX |
| FINAL ASSY NUM | XXXXX |
| DEVICE ID | XXXXX |

DETRONICS

6901 WEST 110TH STREET

MINNEAPOLIS, MN 55438

USA

FAULT/STATUS

- OP MODE XXXXX
- FAULT Y/N
- STATUS Y/N

FAULT

| | |
|------------------|--------|
| LOW CAL LINE | ON/OFF |
| EE FAULT | ON/OFF |
| ADC FAULT | ON/OFF |
| 24V FAULT | ON/OFF |
| FLASH FAULT | ON/OFF |
| RAM FAULT | ON/OFF |
| WDT FAULT | ON/OFF |
| 12V FAULT | ON/OFF |
| 5V FAULT | ON/OFF |
| 1.25V FAULT | ON/OFF |
| O/P LOOP FAULT | ON/OFF |
| INPUT LOOP FAULT | ON/OFF |
| 0V FAULT | ON/OFF |
| ADC REF FAULT | ON/OFF |

STATUS

| | |
|------------------|--------|
| ANY FAULT | ON/OFF |
| CAL ACTIVE | ON/OFF |
| WARM UP | ON/OFF |
| LOW RELAY ACTIVE | ON/OFF |
| HI RELAY ACTIVE | ON/OFF |
| AUX RELAY ACTIVE | ON/OFF |
| CURRENT FIXED | ON/OFF |
| MB WRITE PROTECT | ON/OFF |
| HART SELF TEST | ON/OFF |
| LON ATTACHED | ON/OFF |
| RESPONSE TEST | ON/OFF |
| MANUAL SELF TEST | ON/OFF |
| INPUT HART | ON/OFF |

DISPLAY HISTORY

| | |
|----------------|----------|
| RUNNING HOURS | XXXX |
| MAX TEMP | XX.XX C |
| MAX TEMP TIME | XX:XX:XX |
| MIN TEMP | XX.XX C |
| MIN TEMP TIME | XX:XX:XX |
| RESET MAX MIN | |
| MAX RESET TEMP | XX.XX C |
| MAX RESET TIME | XX:XX:XX |
| MIN RESET TEMP | XX.XX C |
| MIN RESET TIME | XX:XX:XX |

HISTORY

- DISPLAY HISTORY →
- EVENT LOG →

EVENT LOG

| | |
|-------|-------------|
| EVENT | XXXXX |
| DATE | DD/MMM/YYYY |
| TIME | HH:MM:SS |

DISPLAY INFO

| | |
|----------------|-------------|
| RTC | → |
| SERIAL NUMBER | XXXXX |
| I/O BOARD ID | XXX |
| MFG DATE | DD/MM/YYYY |
| F/W REV | XXXXX |
| UNIVERSAL REV | XXXXX |
| FIELD DEV REV | XXXXX |
| RUNNING HOURS | XXXXX |
| TEMPERATURE | XX.XX C |
| HEATER CTRL | AUTO/ON/OFF |
| BACKLIGHT CTRL | AUTO/ON/OFF |
| INPUT VOLTAGE | XX.XX |

RTC

| | |
|-----------|-----|
| DISPLAYED | Y/N |
| SECONDS | XX |
| MINUTES | XX |
| HOURS | XX |
| DAY | XX |
| MONTH | XX |
| YEAR | XX |

RS485

| | |
|--------------|-------|
| BAUD RATE | XXXXX |
| PARITY | XXXXX |
| POLL ADDRESS | XXXXX |

DEBUG MENU

| | |
|--------------------|----------|
| HART ERRORS | XXXXX |
| MODBUS ERRORS | XXXXX |
| ERROR DETAILS | → |
| OUTPUT READBACK | XX.XX MA |
| ANALOG INPUT | XX.XX MA |
| MAXIMUM CYCLE TIME | XXXXX |
| AVERAGE CYCLE TIME | XXXXX |

ERROR DETAILS

- HART MASTER →
- HART SLAVE →
- MODBUS →

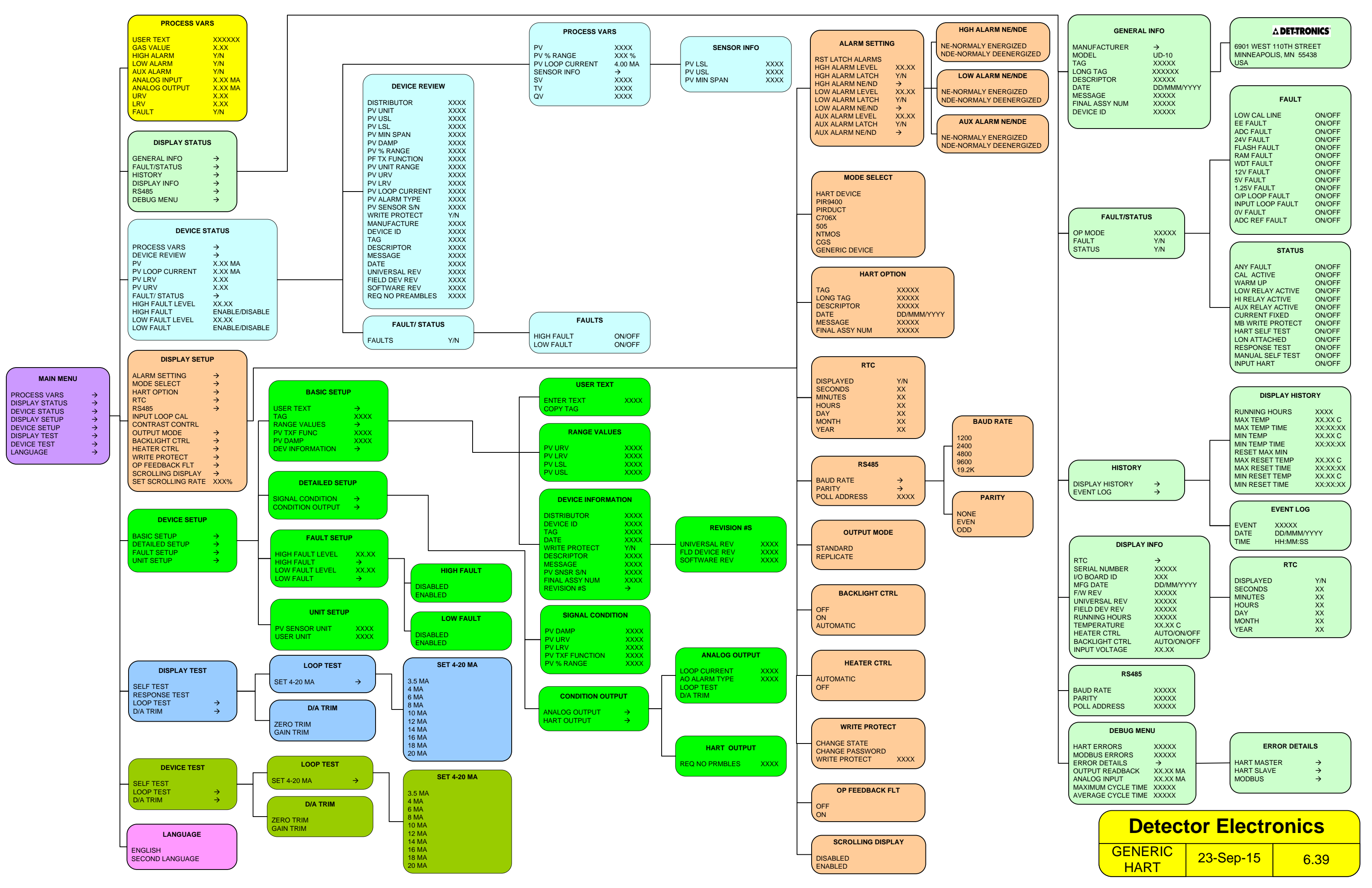

PROCESS VARS

| | |
|---------------|---------|
| USER TEXT | XXXXXX |
| GAS VALUE | X.XX |
| HIGH ALARM | Y/N |
| LOW ALARM | Y/N |
| AUX ALARM | Y/N |
| ANALOG INPUT | X.XX MA |
| ANALOG OUTPUT | X.XX MA |
| URV | X.XX |
| LRV | X.XX |
| FAULT | Y/N |

DISPLAY STATUS

- GENERAL INFO →
- FAULT/STATUS →
- HISTORY →
- DISPLAY INFO →
- RS485 →
- DEBUG MENU →

DEVICE STATUS

- PROCESS VARS →
- DEVICE REVIEW →
- PV X.XX MA
- PV LOOP CURRENT X.XX MA
- PV LRV X.XX
- PV URV X.XX
- FAULT/STATUS →
- HIGH FAULT LEVEL XX.XX
- HIGH FAULT ENABLE/DISABLE
- LOW FAULT LEVEL XX.XX
- LOW FAULT ENABLE/DISABLE

DISPLAY SETUP

- ALARM SETTING →
- MODE SELECT →
- HART OPTION →
- RTC →
- RS485 →
- INPUT LOOP CAL →
- CONTRAST CONTRL →
- OUTPUT MODE →
- BACKLIGHT CTRL →
- HEATER CTRL →
- WRITE PROTECT →
- OP FEEDBACK FLT →
- SCROLLING DISPLAY →
- SET SCROLLING RATE XXX%

DEVICE SETUP

- BASIC SETUP →
- DETAILED SETUP →
- FAULT SETUP →
- UNIT SETUP →

DISPLAY TEST

- SELF TEST
- RESPONSE TEST
- LOOP TEST →
- D/A TRIM →

DEVICE TEST

- SELF TEST
- LOOP TEST →
- D/A TRIM →

LANGUAGE

- ENGLISH
- SECOND LANGUAGE

DEVICE REVIEW

| | |
|------------------|------|
| DISTRIBUTOR | XXXX |
| PV UNIT | XXXX |
| PV USL | XXXX |
| PV LSL | XXXX |
| PV MIN SPAN | XXXX |
| PV DAMP | XXXX |
| PV % RANGE | XXXX |
| PF TX FUNCTION | XXXX |
| PV UNIT RANGE | XXXX |
| PV URV | XXXX |
| PV LRV | XXXX |
| PV LOOP CURRENT | XXXX |
| PV ALARM TYPE | XXXX |
| PV SENSOR S/N | XXXX |
| WRITE PROTECT | Y/N |
| MANUFACTURE | XXXX |
| DEVICE ID | XXXX |
| TAG | XXXX |
| DESCRIPTOR | XXXX |
| MESSAGE | XXXX |
| DATE | XXXX |
| UNIVERSAL REV | XXXX |
| FIELD DEV REV | XXXX |
| SOFTWARE REV | XXXX |
| REQ NO PREAMBLES | XXXX |

FAULT/STATUS

| | |
|--------|-----|
| FAULTS | Y/N |
|--------|-----|

PROCESS VARS

| | |
|-----------------|---------|
| PV | XXXX |
| PV % RANGE | XXX % |
| PV LOOP CURRENT | 4.00 MA |
| SENSOR INFO | → |
| SV | XXXX |
| TV | XXXX |
| QV | XXXX |

SENSOR INFO

| | |
|-------------|------|
| PV LSL | XXXX |
| PV USL | XXXX |
| PV MIN SPAN | XXXX |

ALARM SETTING

| | |
|------------------|-------|
| RST LATCH ALARMS | XX.XX |
| HGH ALARM LEVEL | Y/N |
| HGH ALARM NE/ND | → |
| LOW ALARM LEVEL | XX.XX |
| LOW ALARM LATCH | Y/N |
| LOW ALARM NE/ND | → |
| AUX ALARM LEVEL | XX.XX |
| AUX ALARM LATCH | Y/N |
| AUX ALARM NE/ND | → |

HGH ALARM NE/NDE

NE-NORMALY ENERGIZED
NDE-NORMALY DEENERGIZED

LOW ALARM NE/NDE

NE-NORMALY ENERGIZED
NDE-NORMALY DEENERGIZED

AUX ALARM NE/NDE

NE-NORMALY ENERGIZED
NDE-NORMALY DEENERGIZED

MODE SELECT

HART DEVICE
PIR9400
PIRDUCT
C706X
505
NTMOS
CGS
GENERIC DEVICE

HART OPTION

| | |
|----------------|-------------|
| TAG | XXXXX |
| LONG TAG | XXXXX |
| DESCRIPTOR | XXXXX |
| DATE | DD/MMM/YYYY |
| MESSAGE | XXXXX |
| FINAL ASSY NUM | XXXXX |

RTC

| | |
|-----------|-----|
| DISPLAYED | Y/N |
| SECONDS | XX |
| MINUTES | XX |
| HOURS | XX |
| DAY | XX |
| MONTH | XX |
| YEAR | XX |

RS485

| | |
|--------------|------|
| BAUD RATE | → |
| POLL ADDRESS | XXXX |

BAUD RATE

1200
2400
4800
9600
19.2K

PARITY

NONE
EVEN
ODD

OUTPUT MODE

STANDARD
REPLICATE

BACKLIGHT CTRL

OFF
ON
AUTOMATIC

HEATER CTRL

AUTOMATIC
OFF

WRITE PROTECT

CHANGE STATE
CHANGE PASSWORD
WRITE PROTECT XXXX

OP FEEDBACK FLT

OFF
ON

SCROLLING DISPLAY

DISABLED
ENABLED

FAULTS

| | |
|------------|--------|
| HIGH FAULT | ON/OFF |
| LOW FAULT | ON/OFF |

USER TEXT

| | |
|------------|------|
| ENTER TEXT | XXXX |
| COPY TAG | → |

RANGE VALUES

| | |
|--------|------|
| PV URV | XXXX |
| PV LRV | XXXX |
| PV LSL | XXXX |
| PV USL | XXXX |

DEVICE INFORMATION

| | |
|----------------|------|
| DISTRIBUTOR | XXXX |
| DEVICE ID | XXXX |
| TAG | XXXX |
| DATE | XXXX |
| WRITE PROTECT | Y/N |
| DESCRIPTOR | XXXX |
| MESSAGE | XXXX |
| PV SNSR S/N | XXXX |
| FINAL ASSY NUM | XXXX |
| REVISION #S | → |

REVISION #S

| | |
|----------------|------|
| UNIVERSAL REV | XXXX |
| FLD DEVICE REV | XXXX |
| SOFTWARE REV | XXXX |

SIGNAL CONDITION

| | |
|-----------------|------|
| PV DAMP | XXXX |
| PV URV | XXXX |
| PV LRV | XXXX |
| PV TXF FUNCTION | XXXX |
| PV % RANGE | XXXX |

CONDITION OUTPUT

- ANALOG OUTPUT →
- HART OUTPUT →

ANALOG OUTPUT

| | |
|---------------|------|
| LOOP CURRENT | XXXX |
| AO ALARM TYPE | XXXX |
| LOOP TEST | → |
| D/A TRIM | → |

HART OUTPUT

| | |
|----------------|------|
| REQ NO PRMBLES | XXXX |
|----------------|------|

BASIC SETUP

- USER TEXT →
- TAG XXXX
- RANGE VALUES →
- PV TXF FUNC XXXX
- PV DAMP XXXX
- DEV INFORMATION →

DETAILED SETUP

- SIGNAL CONDITION →
- CONDITION OUTPUT →

FAULT SETUP

| | |
|------------------|-------|
| HIGH FAULT LEVEL | XX.XX |
| HIGH FAULT | → |
| LOW FAULT LEVEL | XX.XX |
| LOW FAULT | → |

HIGH FAULT

DISABLED
ENABLED

LOW FAULT

DISABLED
ENABLED

UNIT SETUP

| | |
|----------------|------|
| PV SENSOR UNIT | XXXX |
| USER UNIT | XXXX |

LOOP TEST

SET 4-20 MA →

| | |
|--------|---|
| 3.5 MA | → |
| 4 MA | → |
| 6 MA | → |
| 8 MA | → |
| 10 MA | → |
| 12 MA | → |
| 14 MA | → |
| 16 MA | → |
| 18 MA | → |
| 20 MA | → |

D/A TRIM

ZERO TRIM
GAIN TRIM

LOOP TEST

SET 4-20 MA →

| | |
|--------|---|
| 3.5 MA | → |
| 4 MA | → |
| 6 MA | → |
| 8 MA | → |
| 10 MA | → |
| 12 MA | → |
| 14 MA | → |
| 16 MA | → |
| 18 MA | → |
| 20 MA | → |

D/A TRIM

ZERO TRIM
GAIN TRIM

GENERAL INFO

| | |
|----------------|-------------|
| MANUFACTURER | → |
| MODEL | UD-10 |
| TAG | XXXXX |
| LONG TAG | XXXXXX |
| DESCRIPTOR | XXXXX |
| DATE | DD/MMM/YYYY |
| MESSAGE | XXXXX |
| FINAL ASSY NUM | XXXXX |
| DEVICE ID | XXXXX |

DETRONICS

6901 WEST 110TH STREET
MINNEAPOLIS, MN 55438
USA

FAULT

| | |
|------------------|--------|
| LOW CAL LINE | ON/OFF |
| EE FAULT | ON/OFF |
| ADC FAULT | ON/OFF |
| 24V FAULT | ON/OFF |
| FLASH FAULT | ON/OFF |
| RAM FAULT | ON/OFF |
| WDT FAULT | ON/OFF |
| 12V FAULT | ON/OFF |
| 5V FAULT | ON/OFF |
| 1.25V FAULT | ON/OFF |
| O/P LOOP FAULT | ON/OFF |
| INPUT LOOP FAULT | ON/OFF |
| 0V FAULT | ON/OFF |
| ADC REF FAULT | ON/OFF |

STATUS

| | |
|------------------|--------|
| ANY FAULT | ON/OFF |
| CAL ACTIVE | ON/OFF |
| WARM UP | ON/OFF |
| LOW RELAY ACTIVE | ON/OFF |
| HI RELAY ACTIVE | ON/OFF |
| AUX RELAY ACTIVE | ON/OFF |
| CURRENT FIXED | ON/OFF |
| MB WRITE PROTECT | ON/OFF |
| HART SELF TEST | ON/OFF |
| LON ATTACHED | ON/OFF |
| RESPONSE TEST | ON/OFF |
| MANUAL SELF TEST | ON/OFF |
| INPUT HART | ON/OFF |

FAULT/STATUS

| | |
|---------|-------|
| OP MODE | XXXXX |
| FAULT | Y/N |
| STATUS | Y/N |

DISPLAY HISTORY

| | |
|----------------|----------|
| RUNNING HOURS | XXXX |
| MAX TEMP | XX.XX C |
| MAX TEMP TIME | XX:XX:XX |
| MIN TEMP | XX.XX C |
| MIN TEMP TIME | XX:XX:XX |
| RESET MAX MIN | → |
| MAX RESET TEMP | XX.XX C |
| MAX RESET TIME | XX:XX:XX |
| MIN RESET TEMP | XX.XX C |
| MIN RESET TIME | XX:XX:XX |

HISTORY

- DISPLAY HISTORY →
- EVENT LOG →

EVENT LOG

| | |
|-------|-------------|
| EVENT | XXXXX |
| DATE | DD/MMM/YYYY |
| TIME | HH:MM:SS |

DISPLAY INFO

| | |
|----------------|-------------|
| RTC | → |
| SERIAL NUMBER | XXXXX |
| I/O BOARD ID | XXX |
| MFG DATE | DD/MM/YYYY |
| F/W REV | XXXXX |
| UNIVERSAL REV | XXXXX |
| FIELD DEV REV | XXXXX |
| RUNNING HOURS | XXXXX |
| TEMPERATURE | XX.XX C |
| HEATER CTRL | AUTO/ON/OFF |
| BACKLIGHT CTRL | AUTO/ON/OFF |
| INPUT VOLTAGE | XX.XX |

RTC

| | |
|-----------|-----|
| DISPLAYED | Y/N |
| SECONDS | XX |
| MINUTES | XX |
| HOURS | XX |
| DAY | XX |
| MONTH | XX |
| YEAR | XX |

RS485

| | |
|--------------|--------|
| BAUD RATE | XXXXXX |
| PARITY | XXXXXX |
| POLL ADDRESS | XXXXXX |

DEBUG MENU

| | |
|--------------------|----------|
| HART ERRORS | XXXXXX |
| MODBUS ERRORS | XXXXXX |
| ERROR DETAILS | → |
| OUTPUT READBACK | XX.XX MA |
| ANALOG INPUT | XX.XX MA |
| MAXIMUM CYCLE TIME | XXXXXX |
| AVERAGE CYCLE TIME | XXXXXX |

ERROR DETAILS

- HART MASTER →
- HART SLAVE →
- MODBUS →

APPENDIX P

UD10 with FLEXSONIC ACOUSTIC GAS DETECTOR

NOTE

For complete information regarding the FlexSonic Acoustic Detector, refer to instruction manual 95-8657.

WIRING

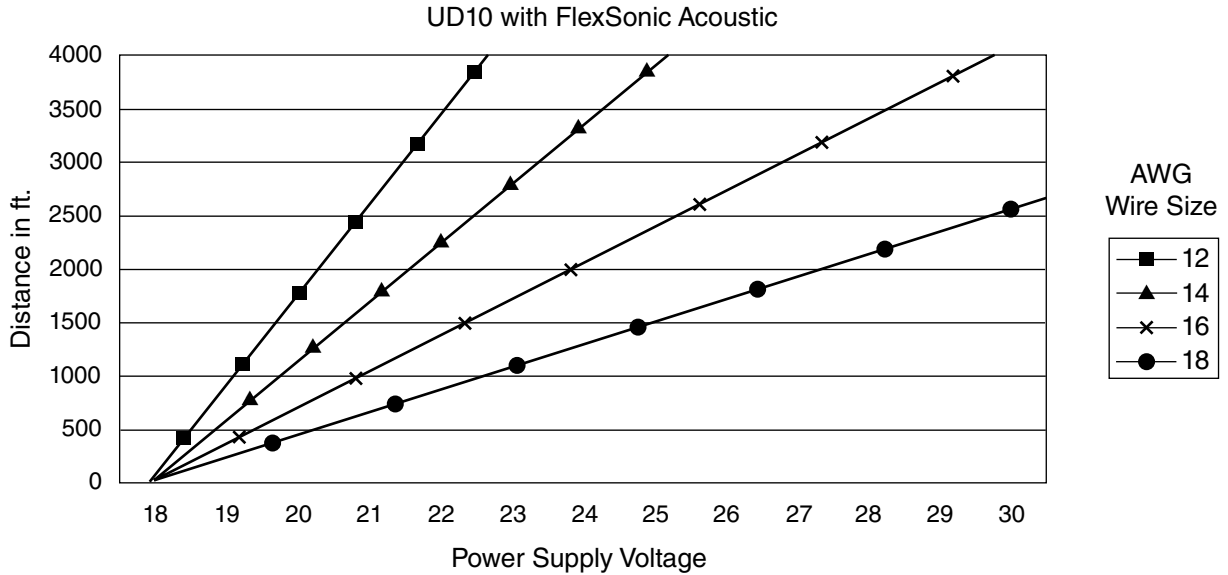

Notes: Maximum recommended cable length from power source to UD10 is 2000 feet.
Maximum recommended cable length from UD10 to sensor is 2000 feet.

INSTALLATION

NOTE

Detector housings must be electrically connected to earth ground. A dedicated earth ground terminal is provided.

NOTE

The AC100 has an Intrinsic Safety (IS) Barrier. Proper NEC/CEC IS grounded must be ensured.

NOTE

The detector must always be installed per local installation codes.

NOTE

Use of a threaded adapter for connecting the AC100 to the STB or ATX10 is prohibited.

NOTE

The ATX10 transmitter module is shipped with the SD card installed in the memory module. A piece of tape has been installed to secure the card in place and prevent it from becoming dislodged during shipping. The shipping tape should be removed prior to commissioning the acoustic detector.

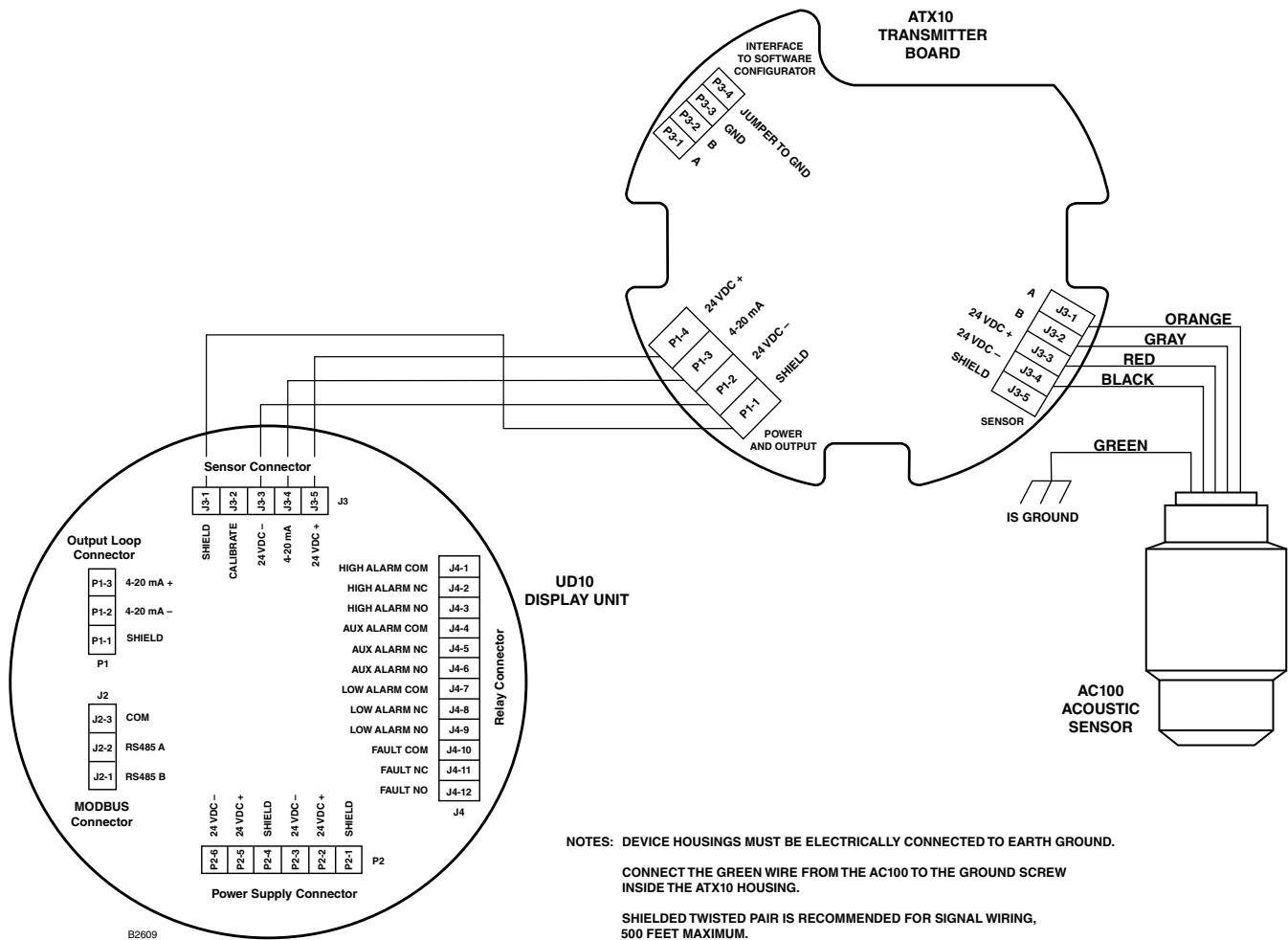

ATX10 Transmitter with AC100 Wired Directly to UD10

UD10 OPERATION

When used with the FlexSonic Acoustic Detector, the main UD10 screen appears as shown in Figure 6-1. The selected alarm mode (Basic or Profile) is displayed in the upper right corner with the alarm level shown in dB. The current date and time are displayed at the bottom of the screen. Alarm or fault status information is shown at the top of the screen.

The spectrum display on the UD10 uses 12 bands to summarize the FlexSonic Detector's 144 band spectrum in the following way:

- The first 4 bands summarize the audible range (20 Hz - 20 kHz). Each of the first 4 bands represents an aggregate of 30 bands from the spectrum, for a total of 120 bands. See Figure 6-2.
- The remaining 8 bands summarize the ultrasonic range from 20 kHz – 80 kHz. Each of the these bands represents an aggregate of 3 bands from the spectrum, for a total of 24 bands.

- The Y axis of the display represents the band amplitude in dB, scaled to fit the full height of the graph at the maximum amplitude of 139 dB.
- The amplitude of displayed bands is determined by taking the peak amplitude of the bands included within each of the aggregated groups of bands.

The alarm threshold is summarized in 12 bands using the method described above. The portion of the band that exceeds the alarm threshold is inverted (displayed in white) as shown in Figure 6-2.

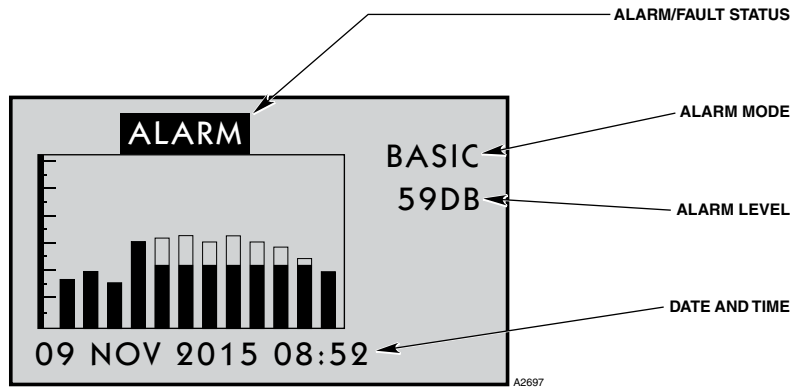

Figure 6-1—UD10 Screen When Used with FlexSonic Acoustic Detector

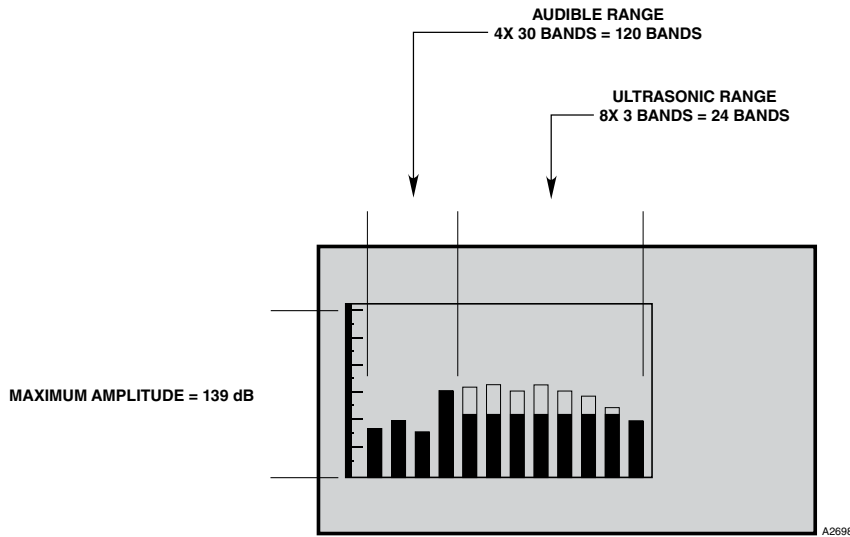

Figure 6-2—UD10 Display Uses 12 Bands to Represent the FlexSonic Acoustic Detector's 144 Bands

MENU STRUCTURE

UD10 with FlexSonic Acoustic Gas Detector

Refer to the following menu when using the UD10's LCD display and internal magnetic switches.

When connecting a HART Communicator to the UD10's 4-20 mA output, refer to the "UD10 HART Handheld" menu in Appendix F.

MENU HELP

*Status menus only allow the user to view the data.
The Setup menus allow the user to both view and edit the data.*

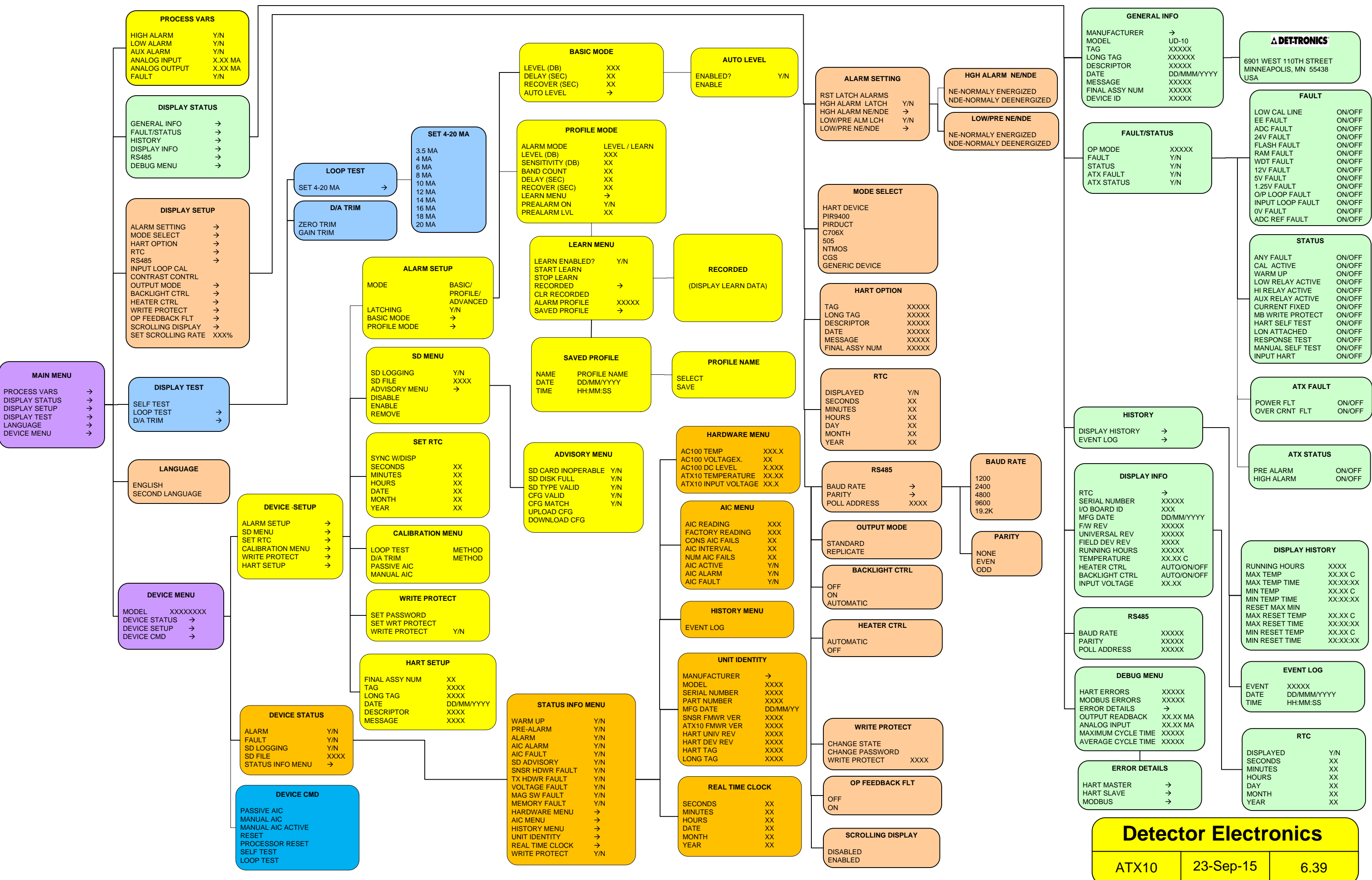

| PROCESS VARS | |
|---------------|---------|
| HIGH ALARM | Y/N |
| LOW ALARM | Y/N |
| AUX ALARM | Y/N |
| ANALOG INPUT | X.XX MA |
| ANALOG OUTPUT | X.XX MA |
| FAULT | Y/N |

| DISPLAY STATUS | |
|----------------|---|
| GENERAL INFO | → |
| FAULT/STATUS | → |
| HISTORY | → |
| DISPLAY INFO | → |
| RS485 | → |
| DEBUG MENU | → |

| DISPLAY SETUP | |
|--------------------|------|
| ALARM SETTING | → |
| MODE SELECT | → |
| HART OPTION | → |
| RTC | → |
| RS485 | → |
| INPUT LOOP CAL | → |
| CONTRAST CONTRL | → |
| OUTPUT MODE | → |
| BACKLIGHT CTRL | → |
| HEATER CTRL | → |
| WRITE PROTECT | → |
| OP FEEDBACK FLT | → |
| SCROLLING DISPLAY | → |
| SET SCROLLING RATE | XXX% |

| MAIN MENU | |
|----------------|---|
| PROCESS VARS | → |
| DISPLAY STATUS | → |
| DISPLAY SETUP | → |
| DISPLAY TEST | → |
| LANGUAGE | → |
| DEVICE MENU | → |

| DISPLAY TEST | |
|--------------|---|
| SELF TEST | → |
| LOOP TEST | → |
| D/A TRIM | → |

| LANGUAGE | |
|-----------------|---|
| ENGLISH | → |
| SECOND LANGUAGE | → |

| DEVICE SETUP | |
|------------------|---|
| ALARM SETUP | → |
| SD MENU | → |
| SET RTC | → |
| CALIBRATION MENU | → |
| WRITE PROTECT | → |
| HART SETUP | → |

| DEVICE MENU | |
|---------------|----------|
| MODEL | XXXXXXXX |
| DEVICE STATUS | → |
| DEVICE SETUP | → |
| DEVICE CMD | → |

| DEVICE STATUS | |
|------------------|------|
| ALARM | Y/N |
| FAULT | Y/N |
| SD LOGGING | Y/N |
| SD FILE | XXXX |
| STATUS INFO MENU | → |

| DEVICE CMD | |
|-------------------|---|
| PASSIVE AIC | → |
| MANUAL AIC | → |
| MANUAL AIC ACTIVE | → |
| RESET | → |
| PROCESSOR RESET | → |
| SELF TEST | → |
| LOOP TEST | → |

| LOOP TEST | |
|-------------|---|
| SET 4-20 MA | → |
| D/A TRIM | → |
| ZERO TRIM | → |
| GAIN TRIM | → |

| SET 4-20 MA | |
|-------------|---|
| 3.5 MA | → |
| 4 MA | → |
| 6 MA | → |
| 8 MA | → |
| 10 MA | → |
| 12 MA | → |
| 14 MA | → |
| 16 MA | → |
| 18 MA | → |
| 20 MA | → |

| ALARM SETUP | |
|--------------|------------------------|
| MODE | BASIC/PROFILE/ADVANCED |
| LATCHING | Y/N |
| BASIC MODE | → |
| PROFILE MODE | → |

| SD MENU | |
|---------------|------|
| SD LOGGING | Y/N |
| SD FILE | XXXX |
| ADVISORY MENU | → |
| DISABLE | → |
| ENABLE | → |
| REMOVE | → |

| SET RTC | |
|-------------|----|
| SYNC W/DISP | XX |
| SECONDS | XX |
| MINUTES | XX |
| HOURS | XX |
| DATE | XX |
| MONTH | XX |
| YEAR | XX |

| CALIBRATION MENU | |
|------------------|--------|
| LOOP TEST | METHOD |
| D/A TRIM | METHOD |
| PASSIVE AIC | → |
| MANUAL AIC | → |

| WRITE PROTECT | |
|-----------------|-----|
| SET PASSWORD | → |
| SET WRT PROTECT | → |
| WRITE PROTECT | Y/N |

| HART SETUP | |
|----------------|------------|
| FINAL ASSY NUM | XX |
| TAG | XXXX |
| LONG TAG | XXXX |
| DATE | DD/MM/YYYY |
| DESCRIPTOR | XXXX |
| MESSAGE | XXXX |

| BASIC MODE | |
|---------------|-----|
| LEVEL (DB) | XXX |
| DELAY (SEC) | XX |
| RECOVER (SEC) | XX |
| AUTO LEVEL | → |

| AUTO LEVEL | |
|------------|-----|
| ENABLED? | Y/N |
| ENABLE | → |

| PROFILE MODE | |
|------------------|---------------|
| ALARM MODE | LEVEL / LEARN |
| LEVEL (DB) | XXX |
| SENSITIVITY (DB) | XX |
| BAND COUNT | XX |
| DELAY (SEC) | XX |
| RECOVER (SEC) | XX |
| LEARN MENU | → |
| PREALARM ON | Y/N |
| PREALARM LVL | XX |

| LEARN MENU | |
|----------------|-------|
| LEARN ENABLED? | Y/N |
| START LEARN | → |
| STOP LEARN | → |
| RECORDED | → |
| CLR RECORDED | → |
| ALARM PROFILE | XXXXX |
| SAVED PROFILE | → |

| RECORDED | |
|----------------------|---|
| (DISPLAY LEARN DATA) | → |

| SAVED PROFILE | |
|---------------|--------------|
| NAME | PROFILE NAME |
| DATE | DD/MM/YYYY |
| TIME | HH:MM:SS |

| PROFILE NAME | |
|--------------|---|
| SELECT | → |
| SAVE | → |

| ADVISORY MENU | |
|--------------------|-----|
| SD CARD INOPERABLE | Y/N |
| SD DISK FULL | Y/N |
| SD TYPE VALID | Y/N |
| CFG VALID | Y/N |
| CFG MATCH | Y/N |
| UPLOAD CFG | → |
| DOWNLOAD CFG | → |

| HARDWARE MENU | |
|---------------------|-------|
| AC100 TEMP | XXX.X |
| AC100 VOLTAGE X. | XX |
| AC100 DC LEVEL | X.XXX |
| ATX10 TEMPERATURE | XX.XX |
| ATX10 INPUT VOLTAGE | XX.X |

| AIC MENU | |
|-----------------|-----|
| AIC READING | XXX |
| FACTORY READING | XXX |
| CONS AIC FAILS | XX |
| AIC INTERVAL | XX |
| NUM AIC FAILS | XX |
| AIC ACTIVE | Y/N |
| AIC ALARM | Y/N |
| AIC FAULT | Y/N |

| HISTORY MENU | |
|--------------|---|
| EVENT LOG | → |

| UNIT IDENTITY | |
|----------------|----------|
| MANUFACTURER | → |
| MODEL | XXXX |
| SERIAL NUMBER | XXXX |
| PART NUMBER | XXXX |
| MFG DATE | DD/MM/YY |
| SNSR FMWR VER | XXXX |
| ATX10 FMWR VER | XXXX |
| HART UNIV REV | XXXX |
| HART DEV REV | XXXX |
| HART TAG | XXXX |
| LONG TAG | XXXX |

| REAL TIME CLOCK | |
|-----------------|----|
| SECONDS | XX |
| MINUTES | XX |
| HOURS | XX |
| DATE | XX |
| MONTH | XX |
| YEAR | XX |

| STATUS INFO MENU | |
|------------------|-----|
| WARM UP | Y/N |
| PRE-ALARM | Y/N |
| ALARM | Y/N |
| AIC ALARM | Y/N |
| AIC FAULT | Y/N |
| SD ADVISORY | Y/N |
| SNSR HDWR FAULT | Y/N |
| TX HDWR FAULT | Y/N |
| VOLTAGE FAULT | Y/N |
| MAG SW FAULT | Y/N |
| MEMORY FAULT | Y/N |
| HARDWARE MENU | → |
| AIC MENU | → |
| HISTORY MENU | → |
| UNIT IDENTITY | → |
| REAL TIME CLOCK | → |
| WRITE PROTECT | Y/N |

| ALARM SETTING | |
|------------------|-----|
| RST LATCH ALARMS | Y/N |
| HGH ALARM LATCH | → |
| HGH ALARM NE/NDE | → |
| LOW/PRE ALM LCH | Y/N |
| LOW/PRE NE/NDE | → |

| HGH ALARM NE/NDE | |
|-------------------------|---|
| NE-NORMALY ENERGIZED | → |
| NDE-NORMALY DEENERGIZED | → |

| LOW/PRE NE/NDE | |
|-------------------------|---|
| NE-NORMALY ENERGIZED | → |
| NDE-NORMALY DEENERGIZED | → |

| MODE SELECT | |
|----------------|---|
| HART DEVICE | → |
| PIR9400 | → |
| PIRDUCT | → |
| C706X | → |
| 505 | → |
| NTMOS | → |
| CGS | → |
| GENERIC DEVICE | → |

| HART OPTION | |
|----------------|-------|
| TAG | XXXXX |
| LONG TAG | XXXXX |
| DESCRIPTOR | XXXXX |
| DATE | XXXXX |
| MESSAGE | XXXXX |
| FINAL ASSY NUM | XXXXX |

| RTC | |
|-----------|-----|
| DISPLAYED | Y/N |
| SECONDS | XX |
| MINUTES | XX |
| HOURS | XX |
| DAY | XX |
| MONTH | XX |
| YEAR | XX |

| RS485 | |
|--------------|------|
| BAUD RATE | → |
| PARITY | → |
| POLL ADDRESS | XXXX |

| OUTPUT MODE | |
|-------------|---|
| STANDARD | → |
| REPLICATE | → |

| BACKLIGHT CTRL | |
|----------------|---|
| OFF | → |
| ON | → |
| AUTOMATIC | → |

| HEATER CTRL | |
|-------------|---|
| AUTOMATIC | → |
| OFF | → |

| WRITE PROTECT | |
|-----------------|------|
| CHANGE STATE | → |
| CHANGE PASSWORD | → |
| WRITE PROTECT | XXXX |

| OP FEEDBACK FLT | |
|-----------------|---|
| OFF | → |
| ON | → |

| SCROLLING DISPLAY | |
|-------------------|---|
| DISABLED | → |
| ENABLED | → |

| GENERAL INFO | |
|----------------|------------|
| MANUFACTURER | → |
| MODEL | UD-10 |
| TAG | XXXXX |
| LONG TAG | XXXXXX |
| DESCRIPTOR | XXXXX |
| DATE | DD/MM/YYYY |
| MESSAGE | XXXXX |
| FINAL ASSY NUM | XXXXX |
| DEVICE ID | XXXXX |

| DETTRONICS | |
|------------------------|---|
| 6901 WEST 110TH STREET | → |
| MINNEAPOLIS, MN 55438 | → |
| USA | → |

| FAULT/STATUS | |
|--------------|-------|
| OP MODE | XXXXX |
| FAULT | Y/N |
| STATUS | Y/N |
| ATX FAULT | Y/N |
| ATX STATUS | Y/N |

| FAULT | |
|------------------|--------|
| LOW CAL LINE | ON/OFF |
| EE FAULT | ON/OFF |
| ADC FAULT | ON/OFF |
| 24V FAULT | ON/OFF |
| FLASH FAULT | ON/OFF |
| RAM FAULT | ON/OFF |
| WDT FAULT | ON/OFF |
| 12V FAULT | ON/OFF |
| 5V FAULT | ON/OFF |
| 1.25V FAULT | ON/OFF |
| O/P LOOP FAULT | ON/OFF |
| INPUT LOOP FAULT | ON/OFF |
| 0V FAULT | ON/OFF |
| ADC REF FAULT | ON/OFF |

| STATUS | |
|------------------|--------|
| ANY FAULT | ON/OFF |
| CAL ACTIVE | ON/OFF |
| WARM UP | ON/OFF |
| LOW RELAY ACTIVE | ON/OFF |
| HI RELAY ACTIVE | ON/OFF |
| AUX RELAY ACTIVE | ON/OFF |
| CURRENT FIXED | ON/OFF |
| MB WRITE PROTECT | ON/OFF |
| HART SELF TEST | ON/OFF |
| LON ATTACHED | ON/OFF |
| RESPONSE TEST | ON/OFF |
| MANUAL SELF TEST | ON/OFF |
| INPUT HART | ON/OFF |

| ATX FAULT | |
|---------------|--------|
| POWER FLT | ON/OFF |
| OVER CRNT FLT | ON/OFF |

| ATX STATUS | |
|------------|--------|
| PRE ALARM | ON/OFF |
| HIGH ALARM | ON/OFF |

| HISTORY | |
|-----------------|---|
| DISPLAY HISTORY | → |
| EVENT LOG | → |

| DISPLAY INFO | |
|----------------|-------------|
| RTC | → |
| SERIAL NUMBER | XXXXX |
| I/O BOARD ID | XXX |
| MFG DATE | DD/MM/YYYY |
| F/W REV | XXXXX |
| UNIVERSAL REV | XXXXX |
| FIELD DEV REV | XXXX |
| RUNNING HOURS | XXXXX |
| TEMPERATURE | XX.XX C |
| HEATER CTRL | AUTO/ON/OFF |
| BACKLIGHT CTRL | AUTO/ON/OFF |
| INPUT VOLTAGE | XX.XX |

| RS485 | |
|--------------|-------|
| BAUD RATE | XXXXX |
| PARITY | XXXXX |
| POLL ADDRESS | XXXXX |

| DEBUG MENU | |
|--------------------|----------|
| HART ERRORS | XXXXX |
| MODBUS ERRORS | XXXXX |
| ERROR DETAILS | → |
| OUTPUT READBACK | XX.XX MA |
| ANALOG INPUT | XX.XX MA |
| MAXIMUM CYCLE TIME | XXXXX |
| AVERAGE CYCLE TIME | XXXXX |

| ERROR DETAILS | |
|---------------|---|
| HART MASTER | → |
| HART SLAVE | → |
| MODBUS | → |

| DISPLAY HISTORY | |
|-----------------|----------|
| RUNNING HOURS | XXXX |
| MAX TEMP | XX.XX C |
| MAX TEMP TIME | XX:XX:XX |
| MIN TEMP | XX.XX C |
| MIN TEMP TIME | XX:XX:XX |
| RESET MAX MIN | → |
| MAX RESET TEMP | XX.XX C |
| MAX RESET TIME | XX:XX:XX |
| MIN RESET TEMP | XX.XX C |
| MIN RESET TIME | XX:XX:XX |

| EVENT LOG | |
|-----------|------------|
| EVENT | XXXXX |
| DATE | DD/MM/YYYY |
| TIME | HH:MM:SS |

| RTC | |
|-----------|-----|
| DISPLAYED | Y/N |
| SECONDS | XX |
| MINUTES | XX |
| HOURS | XX |
| DAY | XX |
| MONTH | XX |
| YEAR | XX |

| | | |
|-----------------------------|-----------|------|
| Detector Electronics | | |
| ATX10 | 23-Sep-15 | 6.39 |

APPENDIX Q

UD10 with MODEL PIRDUCT

NOTE

For complete information regarding the PIRDUCT Gas Detector, refer to instruction manual 95-8573.

WIRING

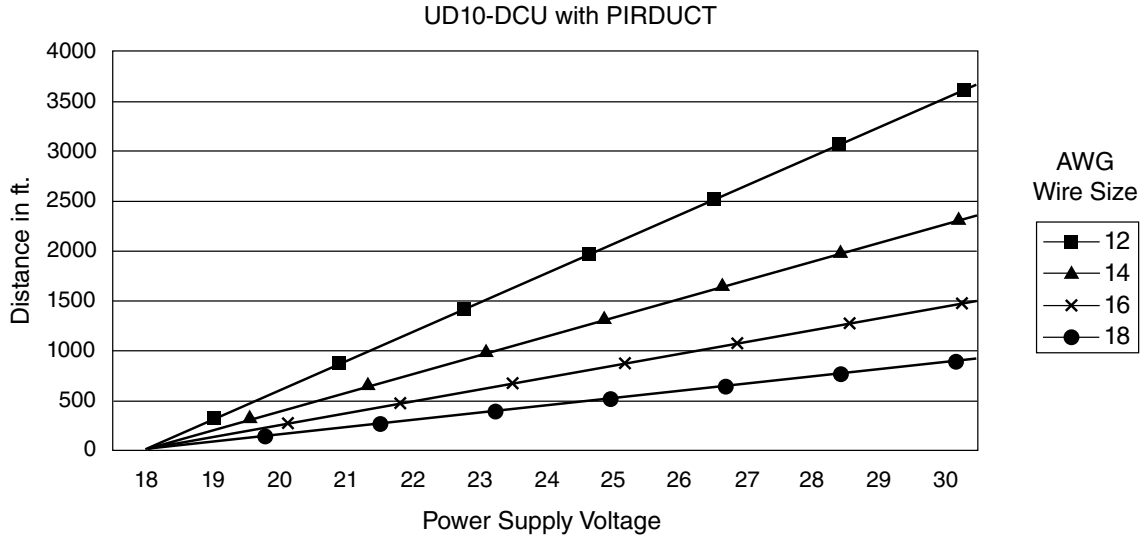

Notes: Maximum recommended cable length from power source to UD10-DCU is 2000 feet.
Maximum recommended cable length from UD10-DCU to PIR9400/PIRTB termination box is 2000 feet.

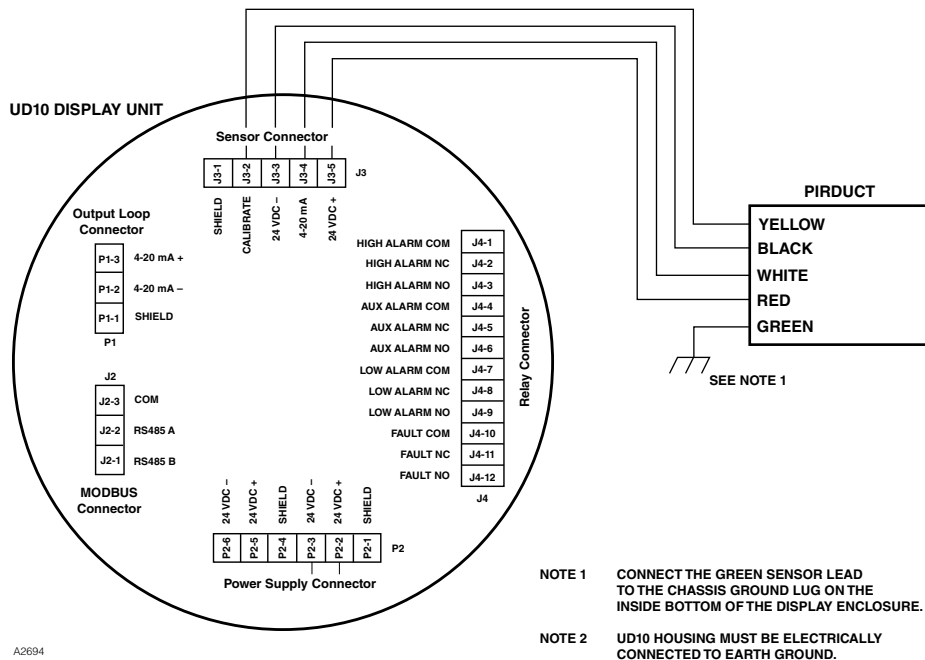

PIRDUCT Wired Directly to UD10

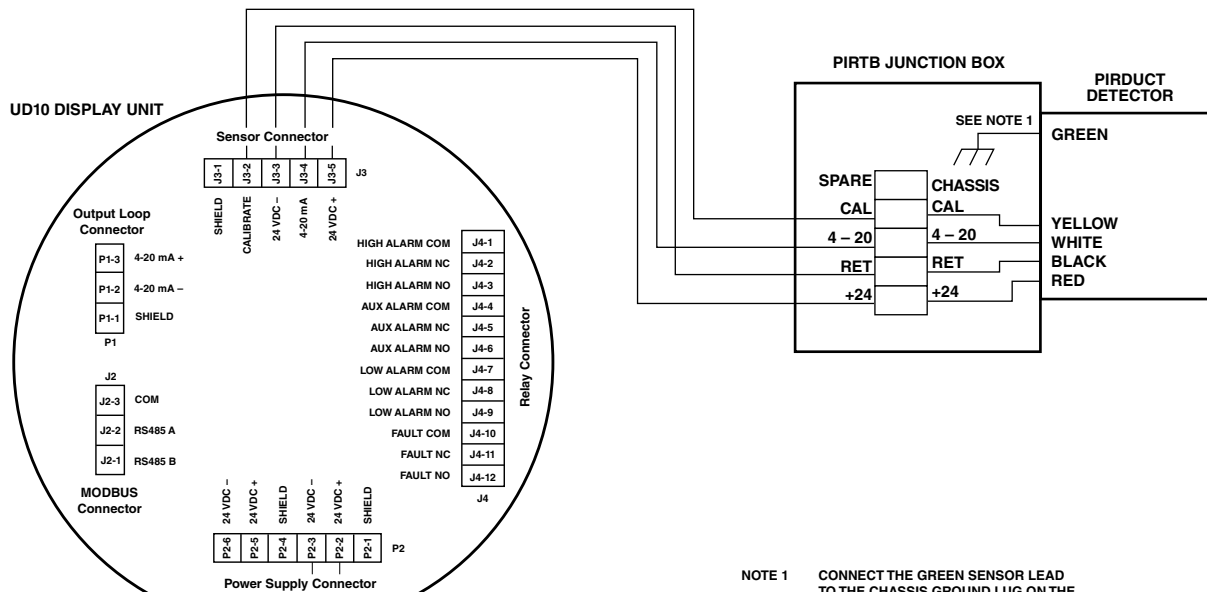

- NOTE 1 CONNECT THE GREEN SENSOR LEAD TO THE CHASSIS GROUND LUG ON THE INSIDE BOTTOM OF THE PIRTB.
- NOTE 2 HOUSINGS MUST BE ELECTRICALLY CONNECTED TO EARTH GROUND.

UD10 Wired to PIRDUCT with PIRTB Termination Box

INSTALLATION NOTES

IMPORTANT

Hydrocarbon-based grease emits hydrocarbon vapors that will be measured by PIRDUCT, resulting in inaccurate gas level readings. **Use only low vapor pressure Lubriplate grease or Teflon tape on the PIRDUCT detector and associated termination box.** Do not get grease on the optics of the detector. A suitable grease is listed in the "Ordering Information" section in this manual.

IMPORTANT

In applications where both PIRDUCT and catalytic type sensors are used, ensure that the grease used to lubricate the PIRDUCT detector threads does not come into contact with the catalytic sensors, since poisoning of the catalytic sensors could result. It is strongly recommended that maintenance personnel wash their hands between handling the two types of sensors.

ORIENTATION

The PIRDUCT Detector is a position sensitive instrument. It must be installed in the proper orientation to achieve proper vapor detection. Ensure that the installation location selected will accommodate the instrument in the proper mounting orientation.

CORRECT



IMPORTANT: MOUNTING PLATE **MUST** BE ORIENTED AS SHOWN. ONCE THE MOUNTING PLATE IS SECURED TO THE DUCT WALL, THE TERMINATION BOX CAN BE ROTATED TO ANY CONVENIENT POSITION.

INCORRECT



Orientation of PIRDUCT Mounting Plate Relative to Direction of Airflow through Duct

CHANGING OPERATING MODES

When used with a PIRDUCT, the operating mode of the UD10 must be changed from “HART Device” to “PIRDUCT” mode. Refer to the “Startup” section of this manual for details.

CALIBRATION

To initiate calibration of the PIRDUCT from the UD10 Display:

- Using the magnet to activate the switches on the UD10 display, navigate to the “Calibration” menu.

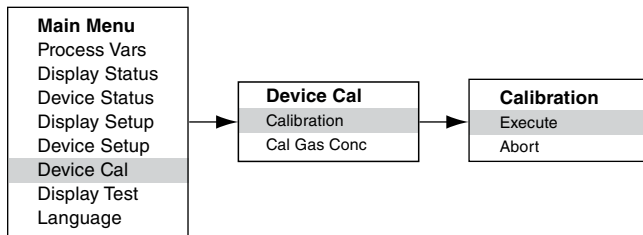

- Activate “Execute” (Enter/Select) to start calibration.
- The UD10 will display “Waiting for Zero” on the main display screen.
- The UD10 will then display “Waiting for Gas” on the screen.
- Apply calibration gas to the PIRDUCT.
- The UD10 will continue to display “Waiting for Gas” on the screen.
- When the UD10 displays “Remove Cal Gas” on the screen, remove the calibration gas from the PIRDUCT.
- The UD10 automatically returns to the normal mode after successful calibration.

To initiate calibration from the PIRTB Termination Box while monitoring calibration using the UD10 display:

- Using the magnet, activate the magnetic calibration switch on the PIRTB Termination Box. The LED at the PIRTB turns from off to steady red.
- The UD10 will display “Waiting for Zero” on the main display screen, with a steady red LED at the PIRTB.

| UD10 mA Output During Calibration (UD10 with PIR9400) | | |
|--|---------------|----------------|
| UD10 Display Reading | Standard Mode | Replicate Mode |
| Waiting for Zero | 3.8 | 2.2 |
| Waiting for Gas | 3.8 | 3.8 |
| Waiting for Span | 3.8 | 3.8 |
| Remove Cal Gas | 3.8 | 3.8 |
| Back to Normal | 4.0 | 4.0 |

- The UD10 will then display “Waiting for Gas” on the screen, while the LED at the PIRTB is flashing red.
- Apply calibration gas to the detector.
- The UD10 will display “Waiting for Span” on the screen, with a red flashing LED at the PIRTB.
- When the UD10 displays “Remove Cal Gas” on the screen and the LED at the PIRTB turns off, remove the calibration gas.
- After successful calibration, the UD10 automatically returns to the normal mode, and the LED on the PIRTB remains off.

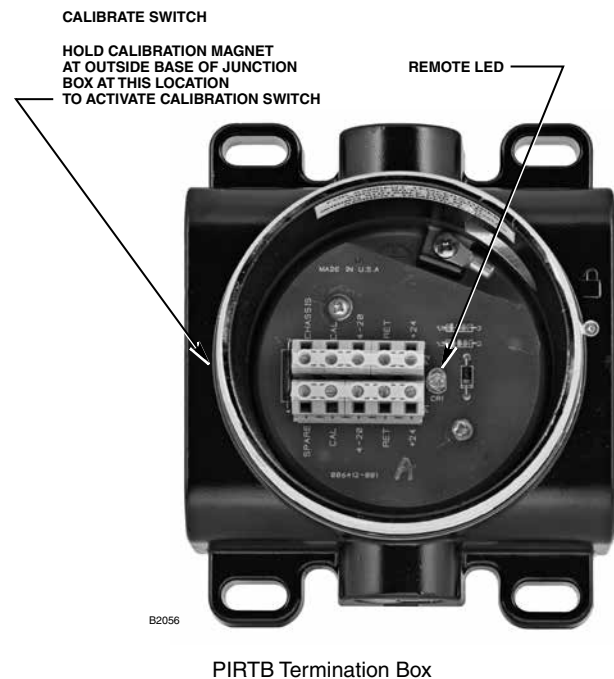

MENU STRUCTURE

UD10 with PIRDUCT Gas Detector

Refer to the following menu when using the UD10's LCD display and internal magnetic switches.

When connecting a HART Communicator to the UD10's 4-20 mA output, refer to the "UD10 HART Handheld" menu in Appendix F.

MENU HELP

Status menus only allow the user to view the data.

The Setup menus allow the user to both view and edit the data.

| PROCESS VARS | |
|---------------|---------|
| GAS NAME | XXXX |
| GAS VALUE | X.XX |
| HIGH ALARM | Y/N |
| LOW ALARM | Y/N |
| AUX ALARM | Y/N |
| ANALOG INPUT | X.XX MA |
| ANALOG OUTPUT | X.XX MA |
| URV | X.XX |
| LRV | X.XX |
| FAULT | Y/N |

| DISPLAY STATUS | |
|----------------|---|
| GENERAL INFO | → |
| FAULT/STATUS | → |
| HISTORY | → |
| DISPLAY INFO | → |
| RS485 | → |
| DEBUG MENU | → |

| DEVICE STATUS | |
|-----------------|---|
| DEVICE INFO | → |
| FAULT/STATUS | → |
| CALIBRATION LOG | → |

| DISPLAY SETUP | |
|--------------------|------|
| ALARM SETTING | → |
| MODE SELECT | → |
| HART OPTION | → |
| RTC | → |
| RS485 | → |
| INPUT LOOP CAL | → |
| CONTRAST CONTRL | → |
| OUTPUT MODE | → |
| BACKLIGHT CTRL | → |
| HEATER CTRL | → |
| WRITE PROTECT | → |
| OP FEEDBACK FLT | → |
| SCROLLING DISPLAY | → |
| SET SCROLLING RATE | XXX% |

| DEVICE SETUP | |
|---------------|---|
| DEVICE OPTION | → |

| DEVICE CAL | |
|--------------|-------|
| CALIBRATION | → |
| CAL GAS CONC | XX.XX |

| DISPLAY TEST | |
|---------------|---|
| SELF TEST | → |
| RESPONSE TEST | → |
| LOOP TEST | → |
| D/A TRIM | → |

| LANGUAGE | |
|-----------------|---|
| ENGLISH | → |
| SECOND LANGUAGE | → |

| DEVICE INFO | |
|-----------------|---------|
| MANUFACTURER | → |
| MODEL | PIRDUCT |
| GAS NAME | XXXXX |
| UNIT OF MEASURE | XXXXX |
| URV | XX.XX |
| LRV | XX.XX |

| FAULTS/ STATUS | |
|----------------|-----|
| FAULTS | Y/N |

| CALIBRATION LOG | |
|-----------------|-------------|
| CAL ID | XXXX |
| DATE | DD/MMM/YYYY |
| TIME | HH:MM:SS |
| ZERO | XXXX |
| SPAN | XXXX |

| DEVICE OPTION | |
|-----------------|-------|
| GAS TYPE | → |
| GAS NAME | XXXXX |
| UNIT OF MEASURE | %LFL |
| URV | XX.XX |
| LRV | XX.XX |

| CALIBRATION | |
|-------------|---|
| EXECUTE | → |
| ABORT | → |

| LOOP TEST | |
|-------------|---|
| SET 4-20 MA | → |

| D/A TRIM | |
|-----------|---|
| ZERO TRIM | → |
| GAIN TRIM | → |

▲ DET-TRONICS
6901 WEST 110TH STREET
MINNEAPOLIS, MN 55438
USA

| FAULTS | |
|------------------|--------|
| WARM UP | ON/OFF |
| REF. CHANNEL FLT | ON/OFF |
| ACT CHANNEL FLT | ON/OFF |
| STARTUP CAL FLT | ON/OFF |
| 24 V FAULT | ON/OFF |
| BLOCK OPTICS | ON/OFF |
| CAL FAULT | ON/OFF |
| LOW FAULT | ON/OFF |
| HIGH FAULT | ON/OFF |

| SET 4-20 MA | |
|-------------|---|
| 3.5MA | → |
| 4 MA | → |
| 6 MA | → |
| 8 MA | → |
| 10 MA | → |
| 12 MA | → |
| 14 MA | → |
| 16 MA | → |
| 18 MA | → |
| 20 MA | → |

| ALARM SETTING | |
|------------------|-------|
| RST LATCH ALARMS | → |
| HGH ALARM LEVEL | XX.XX |
| HGH ALARM LATCH | Y/N |
| HGH ALARM NE/ND | → |
| LOW ALARM LEVEL | XX.XX |
| LOW ALARM LATCH | Y/N |
| LOW ALARM NE/ND | → |
| AUX ALARM LEVEL | XX.XX |
| AUX ALARM LATCH | Y/N |
| AUX ALARM NE/ND | → |

| HGH ALARM NE/NDE | |
|-------------------------|---|
| NE-NORMALY ENERGIZED | → |
| NDE-NORMALY DEENERGIZED | → |

| LOW ALARM NE/NDE | |
|-------------------------|---|
| NE-NORMALY ENERGIZED | → |
| NDE-NORMALY DEENERGIZED | → |

| AUX ALARM NE/NDE | |
|-------------------------|---|
| NE-NORMALY ENERGIZED | → |
| NDE-NORMALY DEENERGIZED | → |

| MODE SELECT | |
|----------------|---|
| HART DEVICE | → |
| PIR9400 | → |
| PIRDUCT | → |
| C706X | → |
| 505 | → |
| NTMOS | → |
| CGS | → |
| GENERIC DEVICE | → |

| HART OPTION | |
|----------------|-------------|
| TAG | XXXXX |
| LONG TAG | XXXXX |
| DESCRIPTOR | XXXXX |
| DATE | DD/MMM/YYYY |
| MESSAGE | XXXXX |
| FINAL ASSY NUM | XXXXX |

| RTC | |
|-----------|-----|
| DISPLAYED | Y/N |
| SECONDS | XX |
| MINUTES | XX |
| HOURS | XX |
| DAY | XX |
| MONTH | XX |
| YEAR | XX |

| RS485 | |
|--------------|------|
| BAUD RATE | → |
| PARITY | → |
| POLL ADDRESS | XXXX |

| BAUD RATE | |
|-----------|---|
| 1200 | → |
| 2400 | → |
| 4800 | → |
| 9600 | → |
| 19.2K | → |

| PARITY | |
|--------|---|
| NONE | → |
| EVEN | → |
| ODD | → |

| OUTPUT MODE | |
|-------------|---|
| STANDARD | → |
| REPLICATE | → |

| BACKLIGHT CTRL | |
|----------------|---|
| OFF | → |
| ON | → |
| AUTOMATIC | → |

| HEATER CTRL | |
|-------------|---|
| AUTOMATIC | → |
| OFF | → |

| WRITE PROTECT | |
|-----------------|------|
| CHANGE STATE | → |
| CHANGE PASSWORD | → |
| WRITE PROTECT | XXXX |

| OP FEEDBACK FLT | |
|-----------------|---|
| OFF | → |
| ON | → |

| SCROLLING DISPLAY | |
|-------------------|---|
| DISABLED | → |
| ENABLED | → |

| GENERAL INFO | |
|----------------|-------------|
| MANUFACTURER | → |
| MODEL | UD-10 |
| TAG | XXXXXX |
| LONG TAG | XXXXXX |
| DESCRIPTOR | XXXXXX |
| DATE | DD/MMM/YYYY |
| MESSAGE | XXXXXX |
| FINAL ASSY NUM | XXXXXX |
| DEVICE ID | XXXXXX |

▲ DET-TRONICS
6901 WEST 110TH STREET
MINNEAPOLIS, MN 55438
USA

| FAULT | |
|------------------|--------|
| LOW CAL LINE | ON/OFF |
| EE FAULT | ON/OFF |
| ADC FAULT | ON/OFF |
| 24V FAULT | ON/OFF |
| FLASH FAULT | ON/OFF |
| RAM FAULT | ON/OFF |
| WDT FAULT | ON/OFF |
| 12V FAULT | ON/OFF |
| 5V FAULT | ON/OFF |
| 1.25V FAULT | ON/OFF |
| O/P LOOP FAULT | ON/OFF |
| INPUT LOOP FAULT | ON/OFF |
| 0V FAULT | ON/OFF |
| ADC REF FAULT | ON/OFF |

| FAULT/STATUS | |
|--------------|-------|
| OP MODE | XXXXX |
| FAULT | Y/N |
| STATUS | Y/N |

| STATUS | |
|------------------|--------|
| ANY FAULT | ON/OFF |
| CAL ACTIVE | ON/OFF |
| WARM UP | ON/OFF |
| LOW RELAY ACTIVE | ON/OFF |
| HI RELAY ACTIVE | ON/OFF |
| AUX RELAY ACTIVE | ON/OFF |
| CURRENT FIXED | ON/OFF |
| MB WRITE PROTECT | ON/OFF |
| HART SELF TEST | ON/OFF |
| LON ATTACHED | ON/OFF |
| RESPONSE TEST | ON/OFF |
| MANUAL SELF TEST | ON/OFF |
| INPUT HART | ON/OFF |

| DISPLAY HISTORY | |
|-----------------|----------|
| RUNNING HOURS | XXXX |
| MAX TEMP | XX.XX C |
| MAX TEMP TIME | XX:XX:XX |
| MIN TEMP | XX.XX C |
| MIN TEMP TIME | XX:XX:XX |
| RESET MAX MIN | → |
| MAX RESET TEMP | XX.XX C |
| MAX RESET TIME | XX:XX:XX |
| MIN RESET TEMP | XX.XX C |
| MIN RESET TIME | XX:XX:XX |

| HISTORY | |
|-----------------|---|
| DISPLAY HISTORY | → |
| EVENT LOG | → |

| EVENT LOG | |
|-----------|-------------|
| EVENT | XXXXX |
| DATE | DD/MMM/YYYY |
| TIME | HH:MM:SS |

| DISPLAY INFO | |
|----------------|-------------|
| RTC | → |
| SERIAL NUMBER | XXXXXX |
| I/O BOARD ID | XXX |
| MFG DATE | DD/MM/YYYY |
| F/W REV | XXXXX |
| UNIVERSAL REV | XXXXX |
| FIELD DEV REV | XXXXX |
| RUNNING HOURS | XXXXX |
| TEMPERATURE | XX.XX C |
| HEATER CTRL | AUTO/ON/OFF |
| BACKLIGHT CTRL | AUTO/ON/OFF |
| INPUT VOLTAGE | XX.XX |

| RTC | |
|-----------|-----|
| DISPLAYED | Y/N |
| SECONDS | XX |
| MINUTES | XX |
| HOURS | XX |
| DAY | XX |
| MONTH | XX |
| YEAR | XX |

| RS485 | |
|--------------|-------|
| BAUD RATE | XXXXX |
| PARITY | XXXXX |
| POLL ADDRESS | XXXXX |

| DEBUG MENU | |
|--------------------|----------|
| HART ERRORS | XXXXX |
| MODBUS ERRORS | XXXXX |
| ERROR DETAILS | → |
| OUTPUT READBACK | XX.XX MA |
| ANALOG INPUT | XX.XX MA |
| MAXIMUM CYCLE TIME | XXXXX |
| AVERAGE CYCLE TIME | XXXXX |

| ERROR DETAILS | |
|---------------|---|
| HART MASTER | → |
| HART SLAVE | → |
| MODBUS | → |

Detector Electronics

PIRDUCT

23-Sep-15

6.39

APPENDIX R

UD10 with MODEL PIRECL CARBON DIOXIDE DETECTOR

NOTE

For complete information regarding the PIRECL CO₂ Gas Detector, refer to instruction manual 95-8676.

WIRING

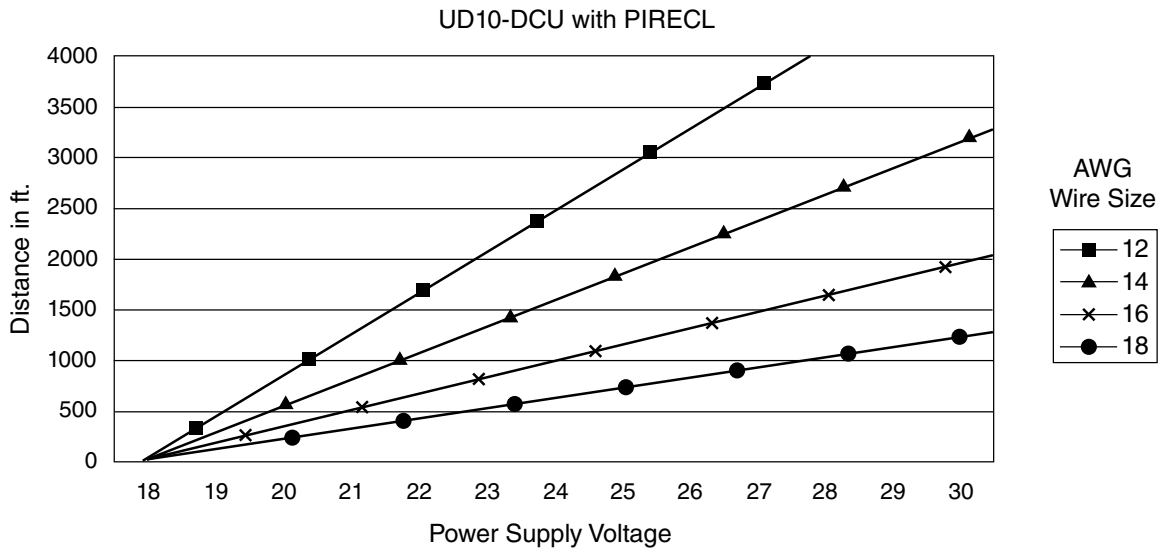

Notes: Maximum recommended cable length from power source to UD10-DCU is 2000 feet.
Maximum recommended cable length from UD10-DCU to detector/STB termination box is 2000 feet.

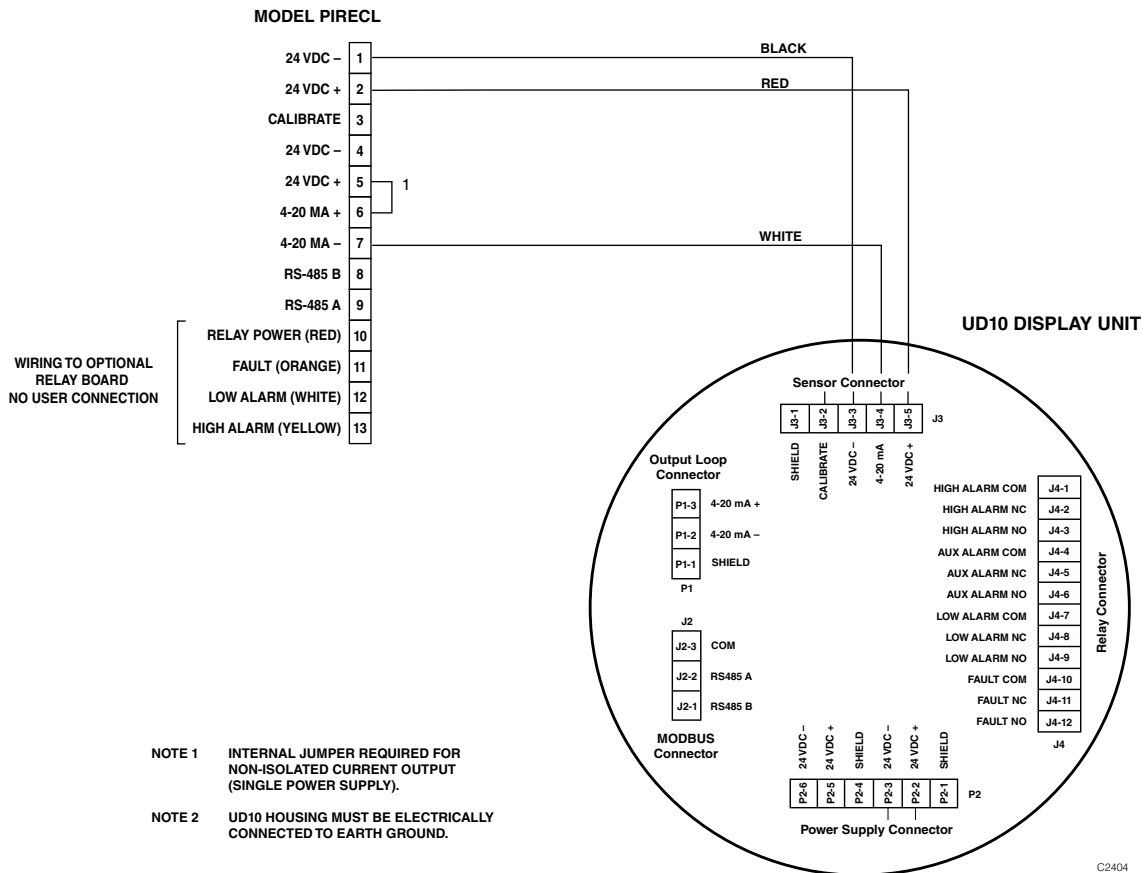

Model PIRECL CO₂ Wired Directly to UD10

ORIENTATION

It is highly recommended that the PIRECL CO₂ be installed in the horizontal position. The detector is not position-sensitive in terms of its ability to detect gas. However, the weather baffle assembly provides superior performance when the PIRECL CO₂ is installed with the baffle in a horizontal position.

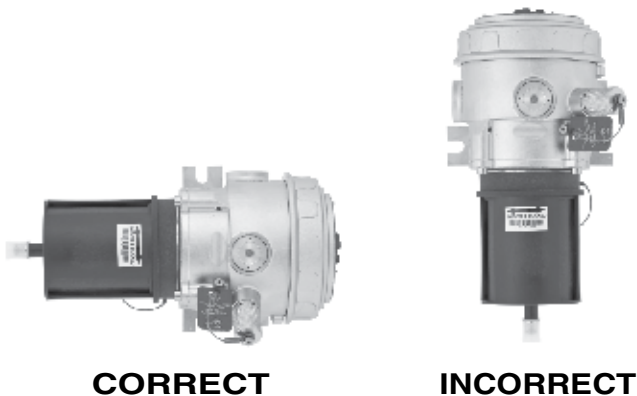

CALIBRATION

To initiate calibration of the PIRECL CO₂ from the UD10 Display:

- Using the magnet to activate the switches on the UD10 display, navigate to the "Calibration" menu.

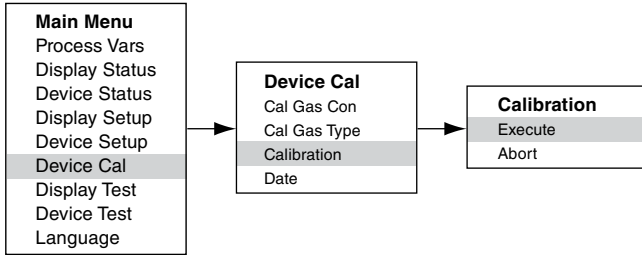

- Activate "Execute" (Enter/Select) to start calibration.
- The UD10 will display "Waiting for Zero" on the main display screen, with a solid red LED on the PIRECL CO₂ housing illuminated.
- The UD10 will then display "Waiting for Gas" on the screen, while the LED on the PIRECL CO₂ is flashing red.
- Apply calibration gas to the PIRECL CO₂.
- The UD10 will display "Waiting for Span" on the screen, while a red flashing LED on the PIRECL CO₂ housing is illuminated.
- When the UD10 displays "Remove Cal Gas" on the screen and the LED on the PIRECL CO₂ housing is off, remove the calibration gas.
- After successful calibration, the UD10 automatically returns to the normal display with the green LED illuminated on the PIRECL CO₂ housing.

To initiate calibration from the PIRECL CO₂ while monitoring calibration using the UD10 display:

- Using the magnet, activate the magnetic calibration switch on the PIRECL CO₂ detector. See Figure below. The LED turns from green to red.
- The UD10 will display "Waiting for Zero" on the main display screen, with a solid red LED on the PIRECL CO₂ housing illuminated.
- The UD10 will then display "Waiting for Gas" on the screen, while the LED on the PIRECL CO₂ is flashing red.
- Apply calibration gas to the PIRECL CO₂ detector.
- The UD10 will display "Waiting for Span" on the screen, while a red flashing LED on the PIRECL CO₂ housing is illuminated.
- When the UD10 displays "Remove Cal Gas" on the screen and the LED on the PIRECL CO₂ housing is off, remove the calibration gas.
- After successful calibration, the UD10 automatically returns to the normal mode with the green LED illuminated on the PIRECL CO₂.

| UD10 mA Output During Calibration (UD10 with PIRECL CO ₂) | | |
|--|---------------|----------------|
| UD10 Display Reading | Standard Mode | Replicate Mode |
| Waiting for Zero | 3.8 | 2.2 |
| Waiting for Gas | 3.8 | 2.0 |
| Waiting for Span | 3.8 | 2.0 |
| Remove Cal Gas | 3.8 | 1.8 |
| Back to Normal | 4.0 | 4.0 |

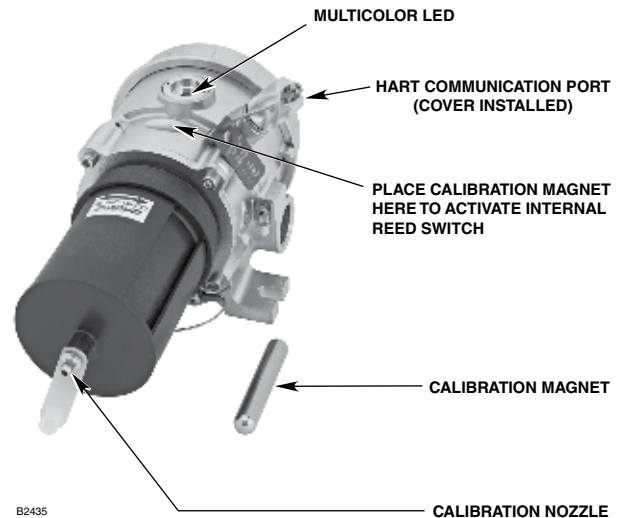

Model PIRECL CO₂ Gas Detector

MENU STRUCTURE

UD10 with Model PIRECL CO₂ Gas Detector

Refer to the following menu when using the UD10's LCD display and internal magnetic switches.

When connecting a HART Communicator to the UD10's 4-20 mA output, refer to the "UD10 HART Handheld" menu in Appendix F.

MENU HELP

Status menus only allow the user to view the data.

The Setup menus allow the user to both view and edit the data.

MAIN MENU

- PROCESS VARS →
- DISPLAY STATUS →
- DEVICE STATUS →
- DISPLAY SETUP →
- DEVICE SETUP →
- DEVICE CAL →
- DISPLAY TEST →
- DEVICE TEST →
- LANGUAGE →

PROCESS VARS

| | |
|---------------|---------|
| GAS NAME | XXXXXX |
| GAS VALUE | X.XX |
| HIGH ALARM | Y/N |
| LOW ALARM | Y/N |
| AUX ALARM | Y/N |
| ANALOG INPUT | X.XX MA |
| ANALOG OUTPUT | X.XX MA |
| URV | X.XX |
| LRV | X.XX |
| FAULT | Y/N |

DISPLAY STATUS

- GENERAL INFO →
- FAULT/STATUS →
- HISTORY →
- DISPLAY INFO →
- RS485 →
- DEBUG MENU →

DEVICE STATUS

- GENERAL INFO →
- FAULT/STATUS →
- DEVICE INFO →
- SENSOR INFO →
- HISTORY →

DISPLAY SETUP

- ALARM SETTING →
- MODE SELECT →
- HART OPTION →
- RTC →
- RS485 →
- INPUT LOOP CAL →
- CONTRAST CONTRL →
- OUTPUT MODE →
- BACKLIGHT CTRL →
- HEATER CTRL →
- WRITE PROTECT →
- OP FEEDBACK FLT →
- SCROLLING DISPLAY →
- SET SCROLLING RATE XXX%

DEVICE SETUP

- DEVICE OPTION →
- ALARM SETTING →
- HART OPTION →
- RS485 →
- WRITE PROTECT →

DEVICE CAL

| | |
|--------------|------------|
| CAL GAS CONC | XX.XX |
| CAL GAS TYPE | → |
| CALIBRATION | → |
| CAL DATE | DD/MM/YYYY |

DISPLAY TEST

- SELF TEST →
- RESPONSE TEST →
- LOOP TEST →
- D/A TRIM →

DEVICE TEST

- SELF TEST →
- RESPONSE TEST →
- LOOP TEST →
- D/A TRIM →

LANGUAGE

- ENGLISH
- SECOND LANGUAGE

ALARM SETTING

| | |
|------------------|-------|
| RST LATCH ALARMS | XX.XX |
| HGH ALARM LEVEL | XX.XX |
| HGH ALARM LATCH | Y/N |
| HGH ALARM NE/ND | → |
| LOW ALARM LEVEL | XX.XX |
| LOW ALARM LATCH | Y/N |
| LOW ALARM NE/ND | → |
| AUX ALARM LEVEL | XX.XX |
| AUX ALARM LATCH | Y/N |
| AUX ALARM NE/ND | → |

HGH ALARM NE/NDE

- NE-NORMALY ENERGIZED
- NDE-NORMALY DEENERGIZED

LOW ALARM NE/NDE

- NE-NORMALY ENERGIZED
- NDE-NORMALY DEENERGIZED

AUX ALARM NE/NDE

- NE-NORMALY ENERGIZED
- NDE-NORMALY DEENERGIZED

MODE SELECT

- HART DEVICE
- PIR9400
- PIRDUCT
- C706X
- 505
- NTMOS
- CGS
- GENERIC DEVICE

HART OPTION

| | |
|----------------|------------|
| TAG | XXXXX |
| LONG TAG | XXXXX |
| DESCRIPTOR | XXXXX |
| DATE | DD/MM/YYYY |
| MESSAGE | XXXXX |
| FINAL ASSY NUM | XXXX |

RTC

| | |
|-----------|-------|
| DISPLAYED | Y/N |
| SECONDS | XXXXX |
| MINUTES | XXXXX |
| HOURS | XXXXX |
| DAY | XXXXX |
| MONTH | XXXXX |
| YEAR | XXXXX |

RS485

| | |
|--------------|------|
| BAUD RATE | → |
| PARITY | → |
| POLL ADDRESS | XXXX |

OUTPUT MODE

- STANDARD
- REPLICATE

BACKLIGHT CTRL

- OFF
- ON
- AUTOMATIC

HEATER CTRL

- AUTOMATIC
- OFF

WRITE PROTECT

- CHANGE STATE
- CHANGE PASSWORD
- WRITE PROTECT XXXX

OP FEEDBACK FLT

- OFF
- ON

SCROLLING DISPLAY

- DISABLED
- ENABLED

DEVICE OPTION

| | |
|-----------------|-------|
| GAS TYPE | → |
| UNIT OF MEASURE | → |
| URV | XX.XX |
| LRV | XX.XX |
| USL | XX.XX |
| LSL | XX.XX |
| ANALOG CODE VAL | → |
| ANALOG FLT CODE | → |

GAS TYPE

- CO2_0-2K_PPM
- CO2_0-5K_PPM
- CO2_0-10K_PPM
- CO2_0-1_VOL%
- CO2_0-2_VOL%
- CO2_0-5_VOL%
- CO2_0-10_VOL%

UNIT OF MEASURE

- PPM
- VOL%

ALARM SETTING

| | |
|------------------|-------|
| RST LATCH ALARMS | XX.XX |
| HGH ALARM LEVEL | XX.XX |
| HGH ALARM LATCH | Y/N |
| LOW ALARM LEVEL | XX.XX |
| LOW ALARM LATCH | Y/N |

HART OPTION

| | |
|----------------|------------|
| TAG | XXXXX |
| LONG TAG | XXXXXX |
| DESCRIPTOR | XXXXX |
| DATE | DD/MM/YYYY |
| MESSAGE | XXXXX |
| FINAL ASSY NUM | XXXXXX |

ANALOG CODE VAL

| | |
|---------------|-------|
| WARM UP | XX.XX |
| BLOCKED OPTIC | XX.XX |
| CALIBRATION | XX.XX |
| FAULT | XX.XX |

ANALOG FAULT CODE

- ECLIPSE
- PIR9400
- USER DEFINED

BAUD RATE

- 1200
- 2400
- 4800
- 9600
- 19.2K

PARITY

- NONE
- EVEN
- ODD

RS485

| | |
|--------------|-----|
| BAUD RATE | → |
| PARITY | → |
| POLL ADDRESS | XXX |

WRITE PROTECT

- CHANGE STATE
- CHANGE PASSWORD
- WRITE PROTECT XXXX

CAL GAS TYPE

- SAME AS MEASURE GAS

CALIBRATION

- EXECUTE
- ABORT

LOOP TEST

- SET 4-20 MA →

D/A TRIM

- ZERO TRIM
- GAIN TRIM

LOOP TEST

- SET 4-20 MA →

D/A TRIM

- ZERO TRIM
- GAIN TRIM

LOOP TEST

- 3.5MA
- 4-MA
- 6 MA
- 8 MA
- 10 MA
- 12 MA
- 14-MA
- 16-MA
- 18-MA
- 20 MA

SET 4-20 MA

- 3.5 MA
- 4 MA
- 6 MA
- 8 MA
- 10 MA
- 12 MA
- 14 MA
- 16 MA
- 18 MA
- 20 MA

GENERAL INFO

| | |
|----------------|------------|
| MANUFACTURER | → |
| MODEL | UD-10 |
| TAG | XXXXX |
| LONG TAG | XXXXXX |
| DESCRIPTOR | XXXXX |
| DATE | DD/MM/YYYY |
| MESSAGE | XXXXX |
| FINAL ASSY NUM | XXXXX |
| DEVICE ID | XXXXX |

DET-TRONICS

6901 WEST 110TH STREET
MINNEAPOLIS, MN 55438
USA

FAULT/STATUS

| | |
|-----------|-------|
| OP MODE | XXXXX |
| CAL STATE | XXXXX |
| FAULT | Y/N |
| STATUS | Y/N |

DEVICE INFO

| | |
|---------------|-------|
| SERIAL NUMBER | XXXXX |
| UNIVERSAL REV | XXXXX |
| FIELD DEV REV | XXXXX |
| S/W REV | XXXXX |

SENSOR INFO

| | |
|-------------|--------|
| ACTIVE | XX.XX |
| REFERENCE | XX.XX |
| RATIO | XX.XX |
| ABSORPTION | XX.XX |
| TEMPERATURE | XX.XXC |
| VOL % | XX.XX |
| USL | XX.XX |
| LSL | XX.XX |
| SPAN FACTOR | XX.XX |

HISTORY

- DEVICE HISTORY →
- CALIBRATION LOG →
- EVENT LOG →

BAUD RATE

- 1200
- 2400
- 4800
- 9600
- 19.2K

PARITY

- NONE
- EVEN
- ODD

FAULT

| | |
|------------------|--------|
| CAL FAULT | ON/OFF |
| DIRTY OPTICS | ON/OFF |
| LAMP FAULT | ON/OFF |
| START CAL FAULT | ON/OFF |
| EE 1 FAULT | ON/OFF |
| EE 2 FAULT | ON/OFF |
| REF ADC SAT | ON/OFF |
| ACTIVE ADC SAT | ON/OFF |
| 24V FAULT | ON/OFF |
| 12V FAULT | ON/OFF |
| 5V FAULT | ON/OFF |
| ZERO DRIFT FAULT | ON/OFF |
| FLASH CRC FAULT | ON/OFF |
| RAM FAULT | ON/OFF |

STATUS

| | |
|----------------|--------|
| CAL ACTIVE | ON/OFF |
| WARM UP | ON/OFF |
| LOW ALARM | ON/OFF |
| HIGH ALARM | ON/OFF |
| HART SELF TEST | ON/OFF |
| CHANGE CONFIG | ON/OFF |

DEVICE HISTORY

| | |
|----------------|---------|
| RUNNING HOURS | XXXXX |
| MAX TEMP | XX.XX C |
| MAX TEMP TIME | XXXX |
| MIN TEMP | XX.XX C |
| MIN TEMP TIME | XXXX |
| RESET MAX MIN | XX.XX C |
| MAX RESET TEMP | XXXX |
| MIN RESET TEMP | XX.XX C |
| MIN RESET TIME | XXXX |

CALIBRATION LOG

| | |
|--------|-------|
| CAL ID | XXXXX |
| HOURS | XXXXX |

EVENT LOG

| | |
|-------|-------|
| EVENT | XXXXX |
| HOURS | XXXXX |

GENERAL INFO

| | |
|----------------|------------|
| MANUFACTURER | → |
| MODEL | UD-10 |
| TAG | XXXXX |
| LONG TAG | XXXXXX |
| DESCRIPTOR | XXXXX |
| DATE | DD/MM/YYYY |
| MESSAGE | XXXXX |
| FINAL ASSY NUM | XXXXX |
| DEVICE ID | XXXXX |

DET-TRONICS

6901 WEST 110TH STREET
MINNEAPOLIS, MN 55438
USA

FAULT/STATUS

| | |
|---------|-------|
| OP MODE | XXXXX |
| FAULT | Y/N |
| STATUS | Y/N |

FAULT

| | |
|------------------|--------|
| LOW CAL LINE | ON/OFF |
| EE FAULT | ON/OFF |
| ADC FAULT | ON/OFF |
| 24V FAULT | ON/OFF |
| FLASH FAULT | ON/OFF |
| RAM FAULT | ON/OFF |
| WDT FAULT | ON/OFF |
| 12V FAULT | ON/OFF |
| 5V FAULT | ON/OFF |
| 1.25V FAULT | ON/OFF |
| O/P LOOP FAULT | ON/OFF |
| INPUT LOOP FAULT | ON/OFF |
| 0V FAULT | ON/OFF |
| ADC REF FAULT | ON/OFF |

STATUS

| | |
|------------------|--------|
| ANY FAULT | ON/OFF |
| CAL ACTIVE | ON/OFF |
| WARM UP | ON/OFF |
| LOW RELAY ACTIVE | ON/OFF |
| HI RELAY ACTIVE | ON/OFF |
| AUX RELAY ACTIVE | ON/OFF |
| CURRENT FIXED | ON/OFF |
| MB WRITE PROTECT | ON/OFF |
| HART SELF TEST | ON/OFF |
| LON ATTACHED | ON/OFF |
| RESPONSE TEST | ON/OFF |
| MANUAL SELF TEST | ON/OFF |
| INPUT HART | ON/OFF |

HISTORY

- DISPLAY HISTORY →
- EVENT LOG →

DISPLAY HISTORY

| | |
|----------------|----------|
| RUNNING HOURS | XXXX |
| MAX TEMP | XX.XX C |
| MAX TEMP TIME | XX:XX:XX |
| MIN TEMP | XX.XX C |
| MIN TEMP TIME | XX:XX:XX |
| RESET MAX MIN | XX.XX C |
| MAX RESET TEMP | XX:XX:XX |
| MIN RESET TEMP | XX.XX C |
| MIN RESET TIME | XX:XX:XX |

DISPLAY INFO

| | |
|----------------|-------------|
| RTC | → |
| SERIAL NUMBER | XXXXX |
| I/O BOARD ID | XXX |
| MFG DATE | DD/MM/YYYY |
| F/W REV | XXXXX |
| UNIVERSAL REV | XXXXX |
| FIELD DEV REV | XXXXX |
| RUNNING HOURS | XXXXX |
| TEMPERATURE | XX.XX C |
| HEATER CTRL | AUTO/ON/OFF |
| BACKLIGHT CTRL | AUTO/ON/OFF |
| INPUT VOLTAGE | XX.XX |

EVENT LOG

| | |
|-------|------------|
| EVENT | XXXXX |
| DATE | DD/MM/YYYY |
| TIME | HH:MM:SS |

RTC

| | |
|-----------|-------|
| DISPLAYED | Y/N |
| SECONDS | XXXXX |
| MINUTES | XXXXX |
| HOURS | XXXXX |
| DAY | XXXXX |
| MONTH | XXXXX |
| YEAR | XXXXX |

RS485

| | |
|--------------|------|
| BAUD RATE | XXXX |
| PARITY | XXXX |
| POLL ADDRESS | XXXX |

DEBUG MENU

| | |
|--------------------|----------|
| HART ERRORS | XXXXX |
| MODBUS ERRORS | XXXXX |
| ERROR DETAILS | → |
| OUTPUT READBACK | XX.XX MA |
| ANALOG INPUT | XX.XX MA |
| MAXIMUM CYCLE TIME | XXXXX |
| AVERAGE CYCLE TIME | XXXXX |

ERROR DETAILS

- HART MASTER →
- HART SLAVE →
- MODBUS →

APPENDIX S

UD10 with LS2000 LINE OF SIGHT GAS DETECTOR

NOTE

For complete information regarding the LS2000 Gas Detector, refer to instruction manual 95-8714.

WIRING

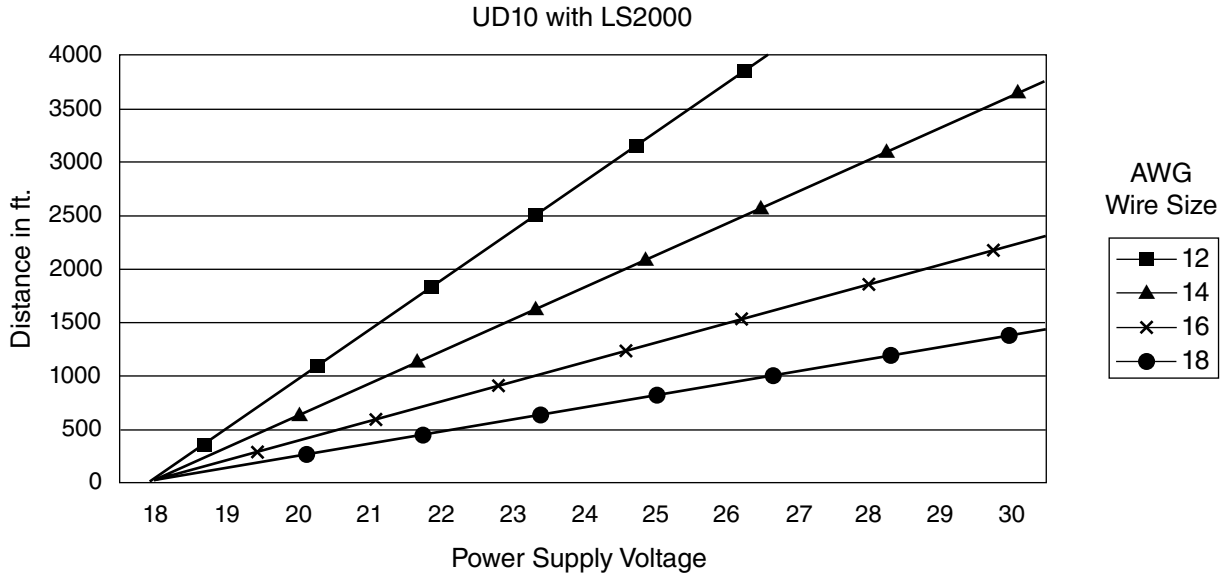

Notes: Maximum recommended cable length from power source to UD10 is 2000 feet.
Maximum recommended cable length from UD10 to sensor is 2000 feet.

LS2000 RECEIVER WITHOUT RELAYS

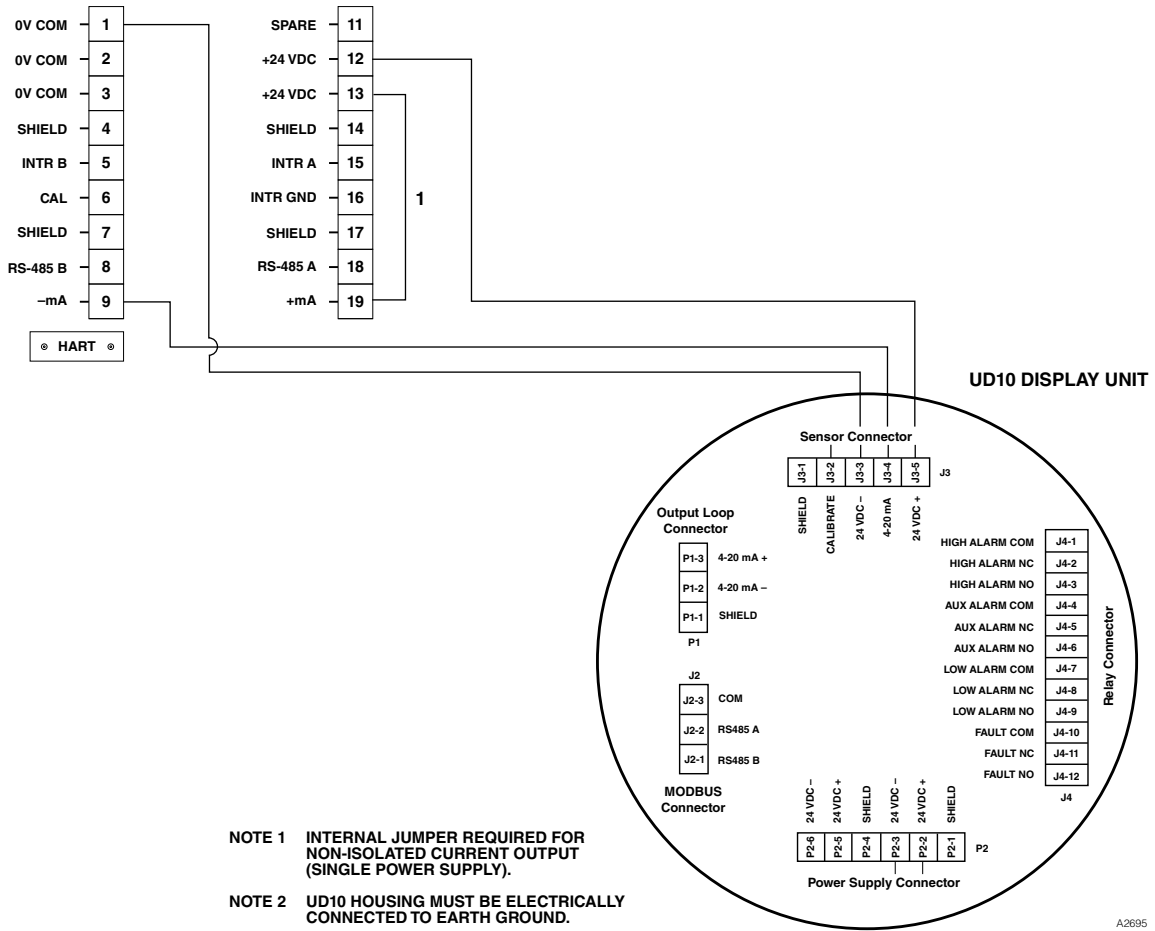

LS2000 Wired Directly to UD10

A2695

INSTALLATION

LS2000 modules must be affixed to a solid, non-vibrating structure capable of supporting a minimum of 100 lbs (46 kg), located within the system's rated separation distance. See examples below.

In all cases, consider whether additional bracing or support is needed to ensure the structural integrity of the module installation. Remember that accurate module alignment is essential for proper performance of a line-of-sight gas detection system. Movement may have a detrimental effect on alignment. This is especially true for installations with significant module separation distances.

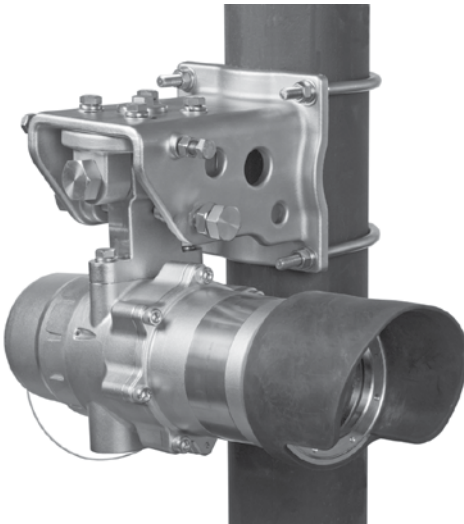

LS2000 Gas Detector Mounted to Vertical Post

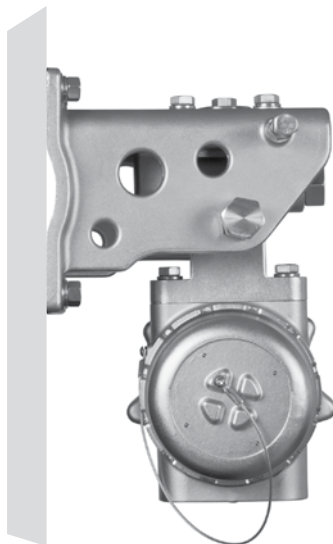

LS2000 Gas Detector Mounted to Flat Surface
(Refer to LS2000 Instruction Manual for mounting plate hole spacing dimensions.)

CALIBRATION

To initiate zero calibration of the LS2000 from the UD10 Display:

- Using the magnet to activate the switches on the UD10 display, navigate to the "Calibration" menu.

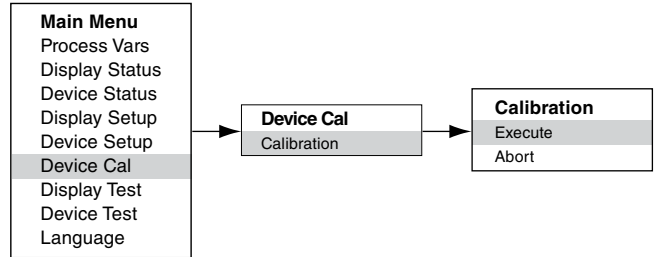

- Activate "Execute" (Enter/Select) to start calibration.
- The UD10 will display "Waiting for Zero" on the main display screen, with a solid red LED on the LS2000 housing illuminated.
- After the calibration is successfully completed, the UD10 automatically returns to the normal display with the green LED illuminated on the LS2000 housing.

| UD10 mA Output During Calibration (UD10 with LS2000) | | |
|---|---------------|----------------|
| UD10 Display Reading | Standard Mode | Replicate Mode |
| Waiting for Zero | 3.8 | 1.0* |
| Back to Normal | 4.0 | 4.0 |

*Can be set at 2.2 mA or as configured by user.

To initiate zero calibration from the LS2000:

1. Using the magnet, activate the magnetic calibration switch on the LS2000 receiver. See Figure below. The green LED will turn red.
2. The UD10 will display "Waiting for Zero" on the main display screen, with a solid red LED on the LS2000 housing illuminated.
3. After the calibration is successfully completed, the UD10 automatically returns to the normal display with the green LED illuminated on the LS2000 housing.

MENU STRUCTURE

UD10 with LS2000 Line of Sight Gas Detector

Refer to the following menu when using the UD10's LCD display and internal magnetic switches.

When connecting a HART Communicator to the UD10's 4-20 mA output, refer to the "UD10 HART" menu in Appendix F.

MENU HELP

*Status menus only allow the user to view the data.
The Setup menus allow the user to both view and edit the data.*

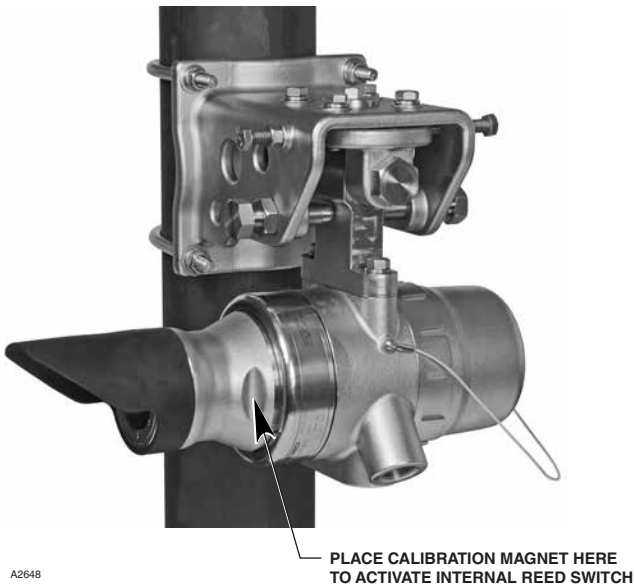

Location of Receiver's Internal Magnetic Switch

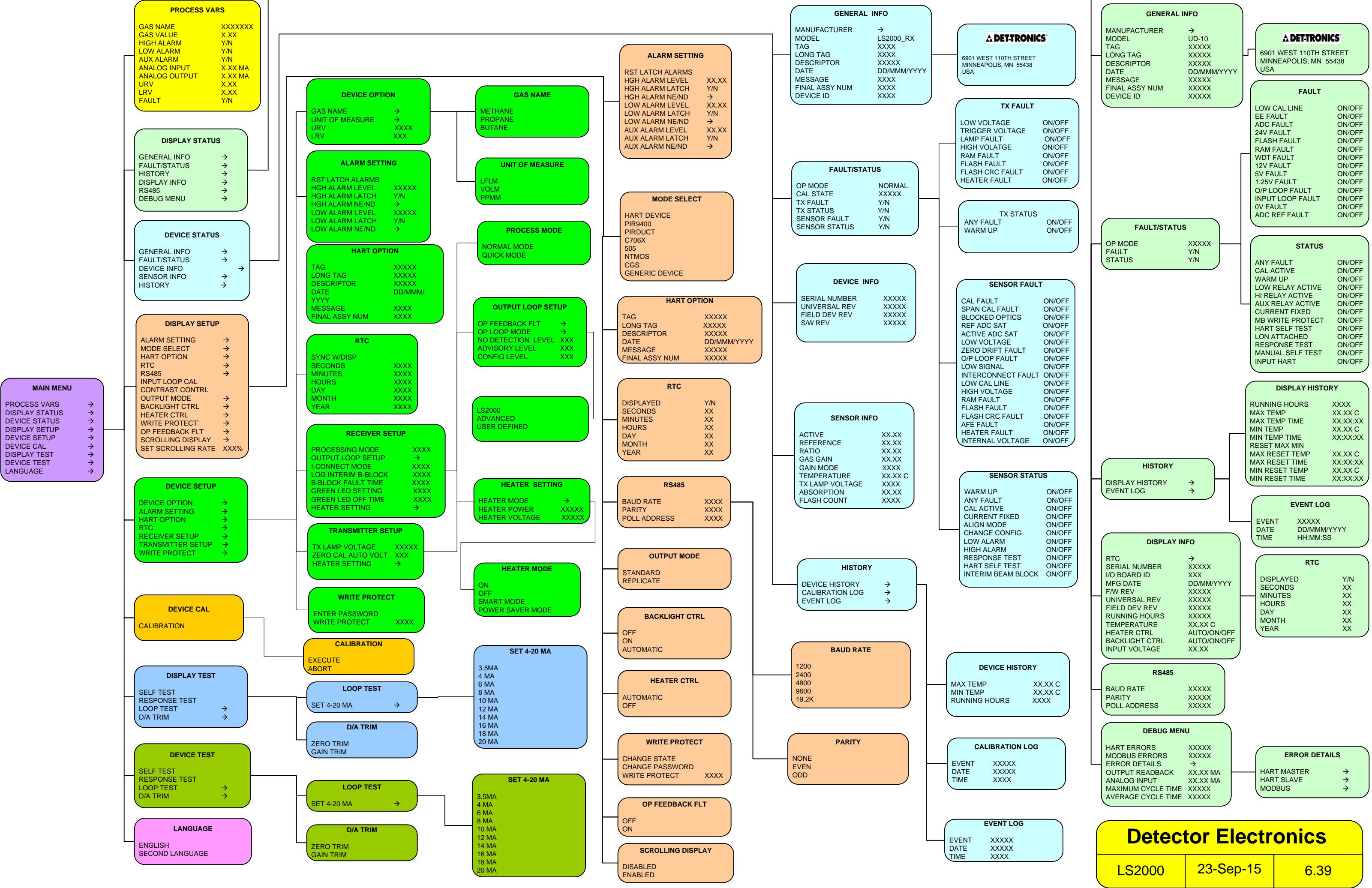

MAIN MENU

- PROCESS VARS →
- DISPLAY STATUS →
- DEVICE STATUS →
- DISPLAY SETUP →
- DEVICE SETUP →
- DEVICE CAL →
- DISPLAY TEST →
- DEVICE TEST →
- LANGUAGE →

PROCESS VARS

| | |
|---------------|---------|
| GAS NAME | XXXXXXX |
| GAS VALUE | X.XX |
| HIGH ALARM | Y/N |
| LOW ALARM | Y/N |
| AUX ALARM | Y/N |
| ANALOG INPUT | X.XX MA |
| ANALOG OUTPUT | X.XX MA |
| URV | X.XX |
| LRV | X.XX |
| FAULT | Y/N |

DISPLAY STATUS

- GENERAL INFO →
- FAULT/STATUS →
- HISTORY →
- DISPLAY INFO →
- RS485 →
- DEBUG MENU →

DEVICE STATUS

- GENERAL INFO →
- FAULT/STATUS →
- DEVICE INFO →
- SENSOR INFO →
- HISTORY →

DISPLAY SETUP

- ALARM SETTING →
- MODE SELECT →
- HART OPTION →
- RTC →
- RS485 →
- INPUT LOOP CAL →
- CONTRAST CONTRL →
- OUTPUT MODE →
- BACKLIGHT CTRL →
- HEATER CTRL →
- WRITE PROTECT →
- OP FEEDBACK FLT →
- SCROLLING DISPLAY →
- SET SCROLLING RATE XXX%

DEVICE SETUP

- DEVICE OPTION →
- ALARM SETTING →
- HART OPTION →
- RTC →
- RECEIVER SETUP →
- TRANSMITTER SETUP →
- WRITE PROTECT →

DEVICE CAL

CALIBRATION

DISPLAY TEST

- SELF TEST →
- RESPONSE TEST →
- LOOP TEST →
- D/A TRIM →

DEVICE TEST

- SELF TEST →
- RESPONSE TEST →
- LOOP TEST →
- D/A TRIM →

LANGUAGE

- ENGLISH
- SECOND LANGUAGE

DEVICE OPTION

- GAS NAME →
- UNIT OF MEASURE →
- URV XXXX
- LRV XXX

ALARM SETTING

- RST LATCH ALARMS XXXXX
- HGH ALARM LEVEL Y/N
- HGH ALARM LATCH →
- HGH ALARM NE/ND →
- LOW ALARM LEVEL XXXXX
- LOW ALARM LATCH Y/N
- LOW ALARM NE/ND →

HART OPTION

- TAG XXXXX
- LONG TAG XXXXX
- DESCRIPTOR XXXXX
- DATE DD/MMM/YYYY
- YYYY
- MESSAGE XXXX
- FINAL ASSY NUM XXXX

RTC

- SYNC W/DISP XXXX
- SECONDS XXXX
- MINUTES XXXX
- HOURS XXXX
- DAY XXXX
- MONTH XXXX
- YEAR XXXX

RECEIVER SETUP

- PROCESSING MODE XXXX
- OUTPUT LOOP SETUP →
- I-CONNECT MODE XXXX
- LOG INTERIM B-BLOCK XXXX
- B-BLOCK FAULT TIME XXXX
- GREEN LED SETTING XXXX
- GREEN LED OFF TIME XXXX
- HEATER SETTING →

TRANSMITTER SETUP

- TX LAMP VOLTAGE XXXXX
- ZERO CAL AUTO VOLT XXX
- HEATER SETTING →

WRITE PROTECT

- ENTER PASSWORD XXXX
- WRITE PROTECT XXXX

CALIBRATION

- EXECUTE
- ABORT

LOOP TEST

- SET 4-20 MA →

D/A TRIM

- ZERO TRIM
- GAIN TRIM

LOOP TEST

- SET 4-20 MA →

D/A TRIM

- ZERO TRIM
- GAIN TRIM

GAS NAME

- METHANE
- PROPANE
- BUTANE

UNIT OF MEASURE

- LFLM
- VOLM
- PPMM

PROCESS MODE

- NORMAL MODE
- QUICK MODE

OUTPUT LOOP SETUP

- OP FEEDBACK FLT →
- OP LOOP MODE →
- NO DETECTION LEVEL XXX
- ADVISORY LEVEL XXX
- CONFIG LEVEL XXX

LS2000

- ADVANCED
- USER DEFINED

HEATER SETTING

- HEATER MODE →
- HEATER POWER XXXXX
- HEATER VOLTAGE XXXXX

HEATER MODE

- ON
- OFF
- SMART MODE
- POWER SAVER MODE

SET 4-20 MA

- 3.5 MA
- 4 MA
- 6 MA
- 8 MA
- 10 MA
- 12 MA
- 14 MA
- 16 MA
- 18 MA
- 20 MA

SET 4-20 MA

- 3.5 MA
- 4 MA
- 6 MA
- 8 MA
- 10 MA
- 12 MA
- 14 MA
- 16 MA
- 18 MA
- 20 MA

ALARM SETTING

- RST LATCH ALARMS
- HGH ALARM LEVEL XX.XX
- HGH ALARM LATCH Y/N
- HGH ALARM NE/ND →
- LOW ALARM LEVEL XX.XX
- LOW ALARM LATCH Y/N
- LOW ALARM NE/ND →
- AUX ALARM LEVEL XX.XX
- AUX ALARM LATCH Y/N
- AUX ALARM NE/ND →

MODE SELECT

- HART DEVICE
- PIR9400
- PIRDUCT
- C706X
- 505
- NTMOS
- CGS
- GENERIC DEVICE

HART OPTION

- TAG XXXXX
- LONG TAG XXXXX
- DESCRIPTOR XXXXX
- DATE DD/MMM/YYYY
- MESSAGE XXXXX
- FINAL ASSY NUM XXXXX

RTC

- DISPLAYED Y/N
- SECONDS XX
- MINUTES XX
- HOURS XX
- DAY XX
- MONTH XX
- YEAR XX

RS485

- BAUD RATE XXXX
- PARITY XXXX
- POLL ADDRESS XXXX

OUTPUT MODE

- STANDARD
- REPLICATE

BACKLIGHT CTRL

- OFF
- ON
- AUTOMATIC

HEATER CTRL

- AUTOMATIC
- OFF

WRITE PROTECT

- CHANGE STATE
- CHANGE PASSWORD
- WRITE PROTECT XXXX

OP FEEDBACK FLT

- OFF
- ON

SCROLLING DISPLAY

- DISABLED
- ENABLED

GENERAL INFO

- MANUFACTURER →
- MODEL LS2000_RX
- TAG XXXX
- LONG TAG XXXX
- DESCRIPTOR XXXXX
- DATE DD/MMM/YYYY
- MESSAGE XXXX
- FINAL ASSY NUM XXXX
- DEVICE ID XXXX

DET-TRONICS

6901 WEST 110TH STREET
MINNEAPOLIS, MN 55438
USA

FAULT/STATUS

- OP MODE NORMAL
- CAL STATE XXXXX
- TX FAULT Y/N
- TX STATUS Y/N
- SENSOR FAULT Y/N
- SENSOR STATUS Y/N

DEVICE INFO

- SERIAL NUMBER XXXXX
- UNIVERSAL REV XXXXX
- FIELD DEV REV XXXXX
- S/W REV XXXXX

SENSOR INFO

- ACTIVE XX.XX
- REFERENCE XX.XX
- RATIO XX.XX
- GAS GAIN XX.XX
- GAIN MODE XXXX
- TEMPERATURE XX.XX C
- TX LAMP VOLTAGE XXXX
- ABSORPTION XX.XX
- FLASH COUNT XXXX

HISTORY

- DEVICE HISTORY →
- CALIBRATION LOG →
- EVENT LOG →

BAUD RATE

- 1200
- 2400
- 4800
- 9600
- 19.2K

PARITY

- NONE
- EVEN
- ODD

TX FAULT

- LOW VOLTAGE ON/OFF
- TRIGGER VOLTAGE ON/OFF
- LAMP FAULT ON/OFF
- HIGH VOLATGE ON/OFF
- RAM FAULT ON/OFF
- FLASH FAULT ON/OFF
- FLASH CRC FAULT ON/OFF
- HEATER FAULT ON/OFF

TX STATUS

- ANY FAULT ON/OFF
- WARM UP ON/OFF

SENSOR FAULT

- CAL FAULT ON/OFF
- SPAN CAL FAULT ON/OFF
- BLOCKED OPTICS ON/OFF
- REF ADC SAT ON/OFF
- ACTIVE ADC SAT ON/OFF
- LOW VOLTAGE ON/OFF
- ZERO DRIFT FAULT ON/OFF
- O/P LOOP FAULT ON/OFF
- LOW SIGNAL ON/OFF
- INTERCONNECT FAULT ON/OFF
- LOW CAL LINE ON/OFF
- HIGH VOLTAGE ON/OFF
- RAM FAULT ON/OFF
- FLASH FAULT ON/OFF
- FLASH CRC FAULT ON/OFF
- AFE FAULT ON/OFF
- HEATER FAULT ON/OFF
- INTERNAL VOLTAGE ON/OFF

SENSOR STATUS

- WARM UP ON/OFF
- ANY FAULT ON/OFF
- CAL ACTIVE ON/OFF
- CURRENT FIXED ON/OFF
- ALIGN MODE ON/OFF
- CHANGE CONFIG ON/OFF
- LOW ALARM ON/OFF
- HIGH ALARM ON/OFF
- RESPONSE TEST ON/OFF
- HART SELF TEST ON/OFF
- INTERIM BEAM BLOCK ON/OFF

DEVICE HISTORY

- MAX TEMP XX.XX C
- MIN TEMP XX.XX C
- RUNNING HOURS XXXX

CALIBRATION LOG

- EVENT XXXXX
- DATE XXXXX
- TIME XXXX

EVENT LOG

- EVENT XXXXX
- DATE XXXXX
- TIME XXXX

GENERAL INFO

- MANUFACTURER →
- MODEL UD-10
- TAG XXXX
- LONG TAG XXXXX
- DESCRIPTOR XXXXX
- DATE DD/MMM/YYYY
- MESSAGE XXXXX
- FINAL ASSY NUM XXXXX
- DEVICE ID XXXXX

DET-TRONICS

6901 WEST 110TH STREET
MINNEAPOLIS, MN 55438
USA

FAULT/STATUS

- OP MODE XXXXX
- FAULT Y/N
- STATUS Y/N

STATUS

- ANY FAULT ON/OFF
- CAL ACTIVE ON/OFF
- WARM UP ON/OFF
- LOW RELAY ACTIVE ON/OFF
- HI RELAY ACTIVE ON/OFF
- AUX RELAY ACTIVE ON/OFF
- CURRENT FIXED ON/OFF
- MB WRITE PROTECT ON/OFF
- HART SELF TEST ON/OFF
- LON ATTACHED ON/OFF
- RESPONSE TEST ON/OFF
- MANUAL SELF TEST ON/OFF
- INPUT HART ON/OFF

DISPLAY HISTORY

- RUNNING HOURS XXXX
- MAX TEMP XX.XX C
- MAX TEMP TIME XX:XX:XX
- MIN TEMP XX.XX C
- MIN TEMP TIME XX:XX:XX
- RESET MAX MIN
- MAX RESET TEMP XX.XX C
- MAX RESET TIME XX:XX:XX
- MIN RESET TEMP XX.XX C
- MIN RESET TIME XX:XX:XX

HISTORY

- DISPLAY HISTORY →
- EVENT LOG →

DISPLAY INFO

- RTC →
- SERIAL NUMBER XXXXX
- I/O BOARD ID XXX
- MFG DATE DD/MM/YYYY
- F/W REV XXXXX
- UNIVERSAL REV XXXXX
- FIELD DEV REV XXXXX
- RUNNING HOURS XXXXX
- TEMPERATURE XX.XX C
- HEATER CTRL AUTO/ON/OFF
- BACKLIGHT CTRL AUTO/ON/OFF
- INPUT VOLTAGE XX.XX

RS485

- BAUD RATE XXXXX
- PARITY XXXXX
- POLL ADDRESS XXXXX

DEBUG MENU

- HART ERRORS XXXXX
- MODBUS ERRORS XXXXX
- ERROR DETAILS →
- OUTPUT READBACK XX.XX MA
- ANALOG INPUT XX.XX MA
- MAXIMUM CYCLE TIME XXXXX
- AVERAGE CYCLE TIME XXXXX

FAULT

- LOW CAL LINE ON/OFF
- EE FAULT ON/OFF
- ADC FAULT ON/OFF
- 24V FAULT ON/OFF
- FLASH FAULT ON/OFF
- RAM FAULT ON/OFF
- WDT FAULT ON/OFF
- 12V FAULT ON/OFF
- 5V FAULT ON/OFF
- 1.25V FAULT ON/OFF
- O/P LOOP FAULT ON/OFF
- INPUT LOOP FAULT ON/OFF
- OV FAULT ON/OFF
- ADC REF FAULT ON/OFF

EVENT LOG

- EVENT XXXXX
- DATE DD/MMM/YYYY
- TIME HH:MM:SS

RTC

- DISPLAYED Y/N
- SECONDS XX
- MINUTES XX
- HOURS XX
- DAY XX
- MONTH XX
- YEAR XX

ERROR DETAILS

- HART MASTER →
- HART SLAVE →
- MODBUS →



95-8661



FlexSonic® Acoustic
Leak Detector



X3301 Multispectrum
IR Flame Detector



PointWatch Eclipse® IR
Combustible Gas Detector



FlexVu® Universal Display
with GT3000 Toxic Gas Detector



Eagle Quantum Premier®
Safety System

Corporate Office

6901 West 110th Street
Minneapolis, MN 55438 USA
www.det-tronics.com

Phone: 952.946.6491
Toll-free: 800.765.3473
Fax: 952.829.8750
det-tronics@det-tronics.com

All trademarks are the property of their respective owners.
© 2018 Detector Electronics Corporation. All rights reserved.

Det-Tronics manufacturing system is certified to ISO 9001—
the world's most recognized quality management standard.

