

Instructions

FlexVu® Explosion-Proof Universal Display Unit Model UD20



Table Of Contents

APPLICATION	1
DESCRIPTION	1
HART Communication	1
Magnetic Switches	2
Device Enclosure	2
Device Display	2
Logging	2
Output Test	2
IMPORTANT SAFETY NOTES	3
INSTALLATION	3
Identification of Vapor(s) to be Detected	3
Identification of Detector Mounting Locations ...	4
Device Mounting Orientation	4
Sensor Separation	4
WIRING	4
Power Supply Requirements	4
Wiring Cable Requirements	5
Wiring Procedure	5
CALIBRATION	9
General Calibration Information	9
Calibration Procedure	10
Input Trim	11
SPECIFICATIONS	11
DEVICE REPAIR AND RETURN	14
ORDERING INFORMATION	14
APPENDIX A —HART COMMUNICATION WITH GT3000	15
APPENDIX B — HART COMMUNICATION WITH PIRECL	17

**FlexVu® Explosion-Proof
Universal Display Unit
Model UD20****IMPORTANT**

Be sure to read and understand the entire instruction manual before installing or operating the gas detection system. The Model UD20 is to be used with GT3000 or PIRECL gas detectors to provide early warning of the presence of a gas mixture. Proper device installation, operation, and maintenance is required to ensure safe and effective operation. If this equipment is used in a manner not specified in this manual, safety protection may be impaired.

APPLICATION

The FlexVu® Model UD20 Universal Display Unit is designed to be used with the GT3000 Toxic Gas Detector or PIRECL Combustible Gas Detector.

The UD20 functions as a pass through device, reading the linear 4-20 mA dc output signal from the gas detector. The detected gas concentration is indicated on an alpha-numeric display. The UD20 automatically detects the gas type and operating range of the sensor to which it is connected via the HART signal.

All electronics are enclosed in an explosion-proof aluminum or stainless steel housing. The display unit is used with a single gas detector, which may be either directly coupled to the display unit, or remotely located using a sensor termination box. The UD20 features non-intrusive calibration, which can be performed by using a handheld magnet to activate internal magnetic switches on the faceplate. Calibration can also be performed by activating the gas detector's internal magnetic reed switch with a magnet.

**DESCRIPTION**

The UD20 provides display and control capabilities for the GT3000 or PIRECL detector, and uses the following I/O:

Signal Inputs:	4-20 mA loop with HART, from the gas detector
User Inputs:	Magnetic switches (4), on the display panel
Visible Outputs:	LCD display
Signal Pass Through:	4-20 mA loop with HART, from the gas detector

HART COMMUNICATION

The UD20 is a HART primary master and communicates with the gas detector, which is a HART slave device. Upon power-up, the UD20 requests the gas type, measurement range, and unit of measure from the gas detector. During normal operation, the UD20 continually polls the gas detector for status information. Because the UD20 is a primary master, a secondary master can also be used to communicate with the gas detector at the same time. If an Asset Management System (AMS) is used, it should be configured as a secondary master to avoid communication conflicts with the UD20.

MAGNETIC SWITCHES

Four internal magnetic switches provide a non-intrusive user interface that allows adjustment of configuration parameters and calibration in the field without the use of a HART handheld device. The switches are labeled as follows:

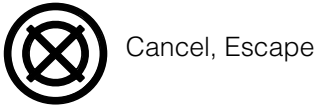

Cancel, Escape



Enter, Select



Previous



Next

DEVICE ENCLOSURE

The housing for the UD20 consists of a multi-port aluminum or stainless steel explosion-proof junction box with a clear viewing window. Available conduit entry sizes include 3/4" NPT and M25.

DEVICE DISPLAY

The UD20 is provided with a 160 x 100 dot matrix LCD display. See Figure 1. During normal operation, the UD20's LCD display indicates the gas type and units measured. The UD20 communicates with the sensor and allows easy access to various operating parameters. Refer to Appendix A or B for details.

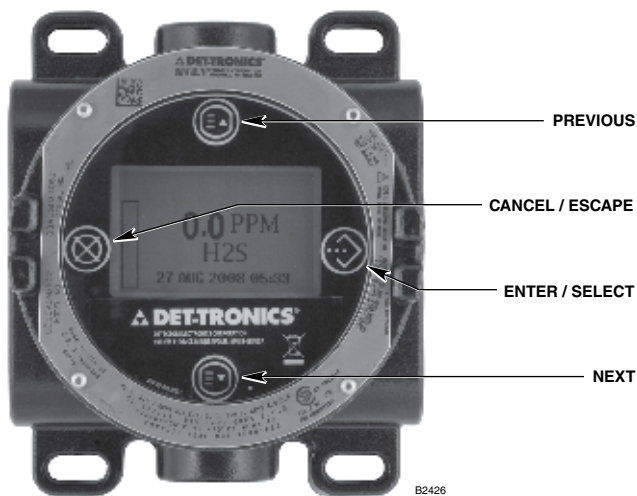

Figure 1—Faceplate of UD20

GAS LEVEL INDICATION

The UD20 display shows “100+” to indicate an over-range condition. For an under-range condition, the gas level indication is 0%. Actual gas level can be determined using the UD20 menu: “PROCESS VARS” > ANALOG INPUT XX.XX mA.

SPECIAL STATES

Special states other than normal operation and warm-up require user action for activation. These include Calibration, Display / Sensor Configuration, Display / Sensor Status, and Fault indication. Refer to Appendix A (UD20 with GT3000) or Appendix B (UD20 with PIRECL) for details regarding the HART menu structure.

WRITE PROTECT

The write protect function in the sensor can be accessed by the UD20.

LOGGING

The UD20 has no logging capability of its own, but reads the logs that are stored in the gas detector and displays them on the LCD screen. If an AMS is used, it communicates directly with the gas detector and not with the UD20.

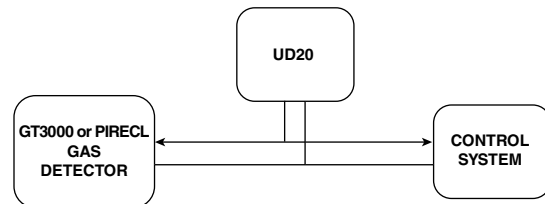

Operating and history logs that are stored in the gas detector and displayed by the UD20 include:

- Calibration
- Sensor running hours
- Sensor temperature
- Events

OUTPUT TEST

The UD20 can start and stop a 4-20 mA Loop Test for checking correct operation of system output devices.

FAULT CONDITIONS WHEN USED WITH PIRECL

When the UD20 is connected to the PIRECL, it automatically programs the PIRECL for "User Defined Fault Mode" upon power-up and sets the following default output levels:

Calibration = 3.8 mA

Warm-up, General Fault, Blocked Optics = 3.0 mA

This is done to ensure that the loop current stays high enough to keep the UD20 powered. The UD20 is a loop powered device and requires a minimum of 2.6 mA to operate properly. Setting the fault level to a value other than default is **not** recommended.

If the UD20 is unable to change the mode, an "ANALOG CODE FLT" fault is annunciated.

Refer to the PIRECL instruction manual, number 95-8526, for complete information regarding fault detection and fault modes.

Zero Drift Condition

Zero Drift Faults are not specifically indicated by the UD20. When the process variable drops between 3.9 and 3.1 mA, no fault is indicated by the UD20. When the process variable reaches 3.0 mA, the UD20 will display a FAULT. If a FAULT condition is indicated, the user can interrogate UD20 and PIRECL fault conditions within the UD20 menu. If no specific fault is indicated, use the menu to determine the PIRECL process variable. If that value is ≤ 3.9 mA, the PIRECL is experiencing zero drift and should be re-calibrated.

IMPORTANT SAFETY NOTES

CAUTION

The wiring procedures in this manual are intended to ensure proper functioning of the device under normal conditions. However, because of the many variations in wiring codes and regulations, total compliance to these ordinances cannot be guaranteed. Be certain that all wiring complies with the NEC as well as all local ordinances. If in doubt, consult the authority having jurisdiction before wiring the system. Installation must be done by a properly trained person.

CAUTION

This product has been tested and approved for use in hazardous areas. However, it must be properly installed and used only under the conditions specified within this manual and the specific approval certificates. Any device modification, improper installation, or use in a

faulty or incomplete configuration will render warranty and product certifications invalid.

CAUTION

The device contains no user serviceable components. Service or repair should never be attempted by the user. Device repair should be performed only by the manufacturer or trained service personnel.

LIABILITIES

The manufacturer's warranty for this product is void, and all liability for proper function of the Display is irrevocably transferred to the owner or operator in the event that the device is serviced or repaired by personnel not employed or authorized by Detector Electronics Corporation, or if the device is used in a manner not conforming to its intended use.

CAUTION

Observe precautions for handling electrostatic sensitive devices.

CAUTION

Unused entries must be closed with suitably certified blanking elements upon installation.

INSTALLATION

NOTE

The UD20 housing must be electrically connected to earth ground. A dedicated earth ground terminal is provided on the UD20.

Install gas detectors in the appropriate locations following the guidelines below. The UD20 should be located where it can be easily viewed by personnel. The GT3000 can be attached directly to the UD20 housing, or it can be mounted remotely using a Det-Tronics STB termination box (see the "Sensor Separation" section for additional information). The Model PIRECL should be mounted as described in the PIRECL instruction manual, number 95-8526. Detectors must always be installed per local installation practices.

Always define the following application details:

IDENTIFICATION OF VAPOR(S) TO BE DETECTED

It is necessary to always identify the vapor(s) of interest at the job site. In addition, the fire hazard properties of the vapor, such as vapor density, flashpoint, and vapor pressure should be identified and used to assist in selecting the optimum detector mounting location within the area.



Figure 2—Correct Mounting Orientation

IDENTIFICATION OF DETECTOR MOUNTING LOCATIONS

Identification of the most likely leak sources and leak accumulation areas is typically the first step in identifying the best detector mounting locations. In addition, identification of air current / wind patterns within the protected area is useful in predicting gas leak dispersion behavior. This information should be used to identify optimum sensor installation points.

If the vapor of interest is lighter than air, place the sensor above the potential gas leak. Place the sensor close to the floor for gases that are heavier than air. Note that air currents may cause a gas that is slightly heavier than air to rise under some conditions. Heated gases may also exhibit the same phenomenon.

The most effective number and placement of detectors varies depending on the conditions at the job site. The individual designing the installation must often rely on experience and common sense to determine the detector quantity and best locations to adequately protect the area. Note that it is typically advantageous to locate detectors where they are accessible for maintenance. Locations near excessive heat or vibration sources should be avoided if possible.

Final suitability of possible gas detector locations should be verified by a job site survey.

For locations with expected periodic temperature conditions from -20°C to -40°C , a certified heater jacket system must be applied, and the installation should be accepted by the local authority having jurisdiction.

DEVICE MOUNTING ORIENTATION

The GT3000 detector must be mounted in a vertical position only, with the sensor pointing down. See Figure 2. For details on mounting the PIRECL detector, refer to manual number 95-8526.

IMPORTANT

The GT3000 must be oriented with the LEDs facing forward so they are easily visible to personnel within the area. To ensure correct orientation (the LEDs are not visible when power is off), position the GND lug on the left hand side and the calibration notch to the front. Note that the LEDs are located directly above the calibration notch.

SENSOR SEPARATION

Det-Tronics sensor termination boxes (Model STBs) enable the installation of the GT3000 separately from the UD20 Universal Display Unit. Two-conductor shielded cable is required to prevent possible nuisance EMI/RFI.

The PIRECL contains its own termination box for sensor separation from the UD20.

The maximum cable length between the termination box and the UD20 is 2000 ft.

WIRING

POWER SUPPLY REQUIREMENTS

Calculate the total gas detection system power consumption rate in watts from cold start-up. Select a power supply with adequate capability for the calculated load. Ensure that the selected power supply provides regulated and filtered 24 Vdc output power for the entire system. If a back-up power system is required, a float-type battery charging system is recommended. If an existing source of 24 Vdc power is being utilized, verify that system requirements are met.

NOTE

The UD20 and GT3000/PIRECL communicate using HART protocol, which requires a power supply with low noise levels for proper operation. (For detailed information regarding power supply specifications, refer to the HART Communication Foundation's document "FSK Physical Layer Specification" HCF_SPEC-54.)

WIRING CABLE REQUIREMENTS

Always use proper cabling type and diameter for input power as well as output signal wiring. 22 to 14 AWG shielded stranded copper wire is recommended. Always install a properly sized, master power fuse or breaker on the system power circuit.

For ambient temperatures below -10°C , use field wiring suitable for the expected conditions. For ambient temperatures above $+60^{\circ}\text{C}$, use field wiring and cable glands suitable for 15°C above the maximum expected conditions.

NOTE

The use of shielded cable in conduit or shielded armored cable is required. In applications where the wiring is installed in conduit, dedicated conduit is recommended. Avoid low frequency, high voltage, and non-signaling conductors to prevent nuisance EMI problems.

CAUTION

The use of proper conduit installation techniques, breathers, glands, and seals is required to prevent water ingress and/or maintain the explosion-proof rating.

JUNCTION BOX ENTRIES, PLUGS, & FITTINGS

WARNING

All entries must contain appropriately rated plugs or fittings. It is required that each plug or fitting be wrench-tightened to an appropriate installation torque and meet the minimum thread engagement requirements per the applicable local standards, codes, and practices in order to retain the defined ratings. PTFE sealant or equivalent should be used on NPT threads.

WIRING PROCEDURE

UD20 with GT3000

Refer to Figures 3 and 4 for wiring illustrations.

UD20 with PIRECL

No separate power lines are required for the UD20. The device can be powered off the PIRECL detector in a two-wire configuration. Figures 5 through 8 illustrate the Eclipse wired to a UD20 with the 4-20 mA output shown in various wiring schemes.

A 250 ohm, 3 watt HART resistor must be installed. The current loop resistance must not exceed 440 ohms for correct functioning of the detector mA output and HART signal.

Figure 9 shows the UD20 with the optional Bartec Self-Regulating Heating Cable System.

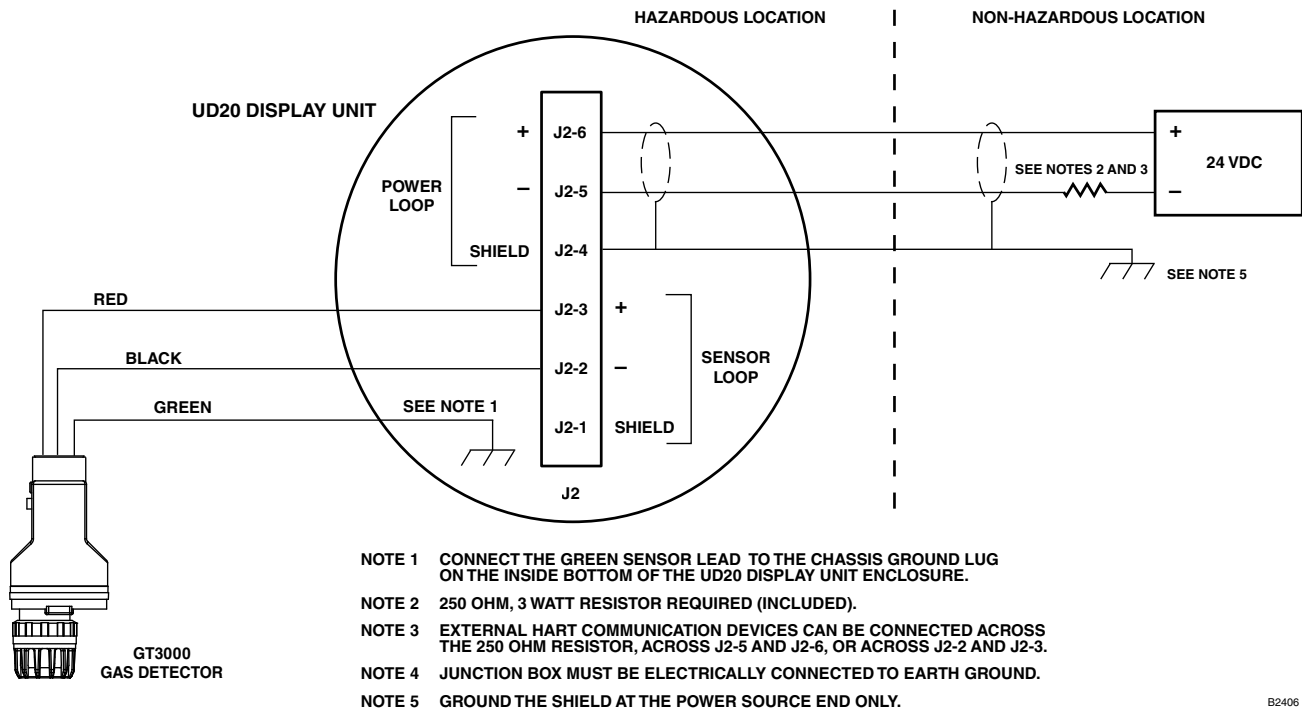
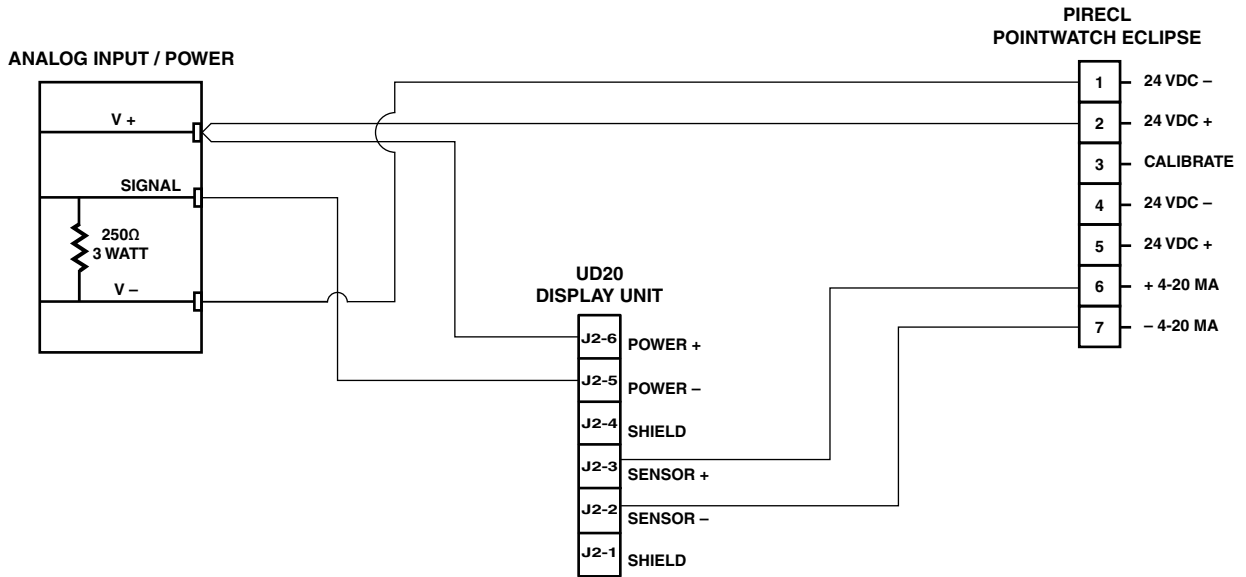

Figure 3—Basic Wiring for Explosion Proof UD20 with GT3000



NOTE 1 JUNCTION BOXES MUST BE ELECTRICALLY CONNECTED TO EARTH GROUND.
 NOTE 2 THE TOTAL LOOP RESISTANCE = 250 OHMS MINIMUM, 440 OHMS MAXIMUM.

B2689

Figure 6—PIRECL Detector Wired to UD20 (Non-Isolated 4-20 mA Output, Sourcing, 4-Wire)

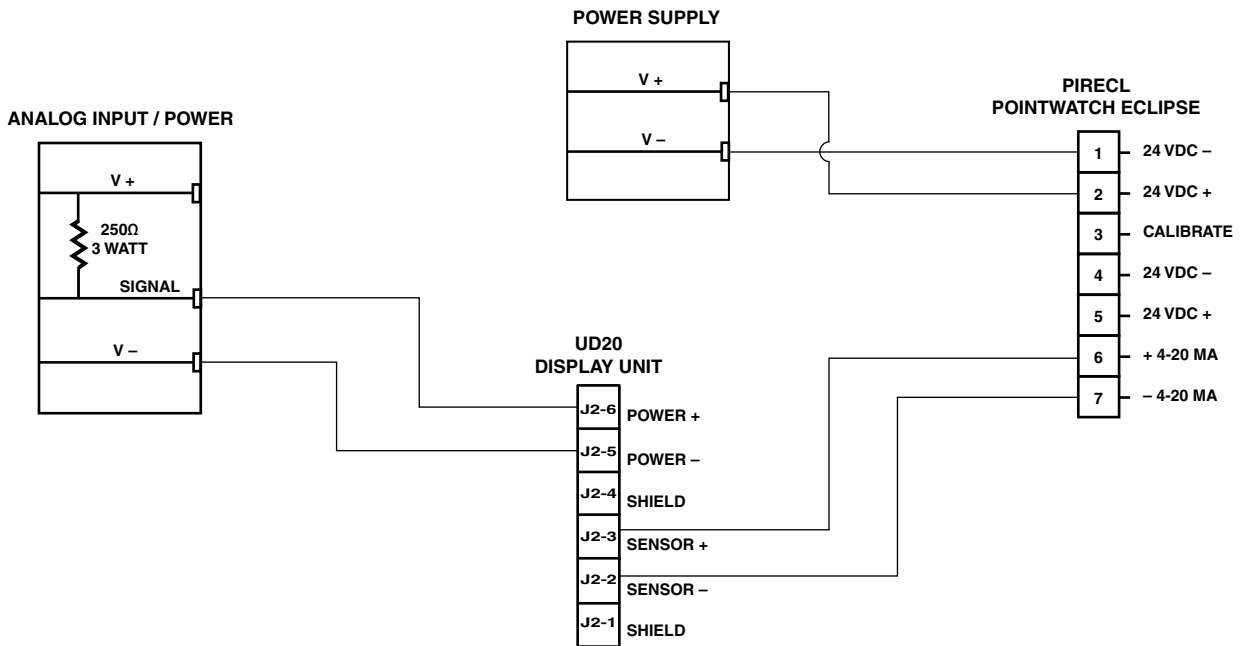

NOTE 1 JUNCTION BOXES MUST BE ELECTRICALLY CONNECTED TO EARTH GROUND.
 NOTE 2 THE TOTAL LOOP RESISTANCE = 250 OHMS MINIMUM, 440 OHMS MAXIMUM.

B2690

Figure 7—PIRECL Detector Wired to UD20 (Isolated 4-20 mA Output, Sinking, 4-Wire)

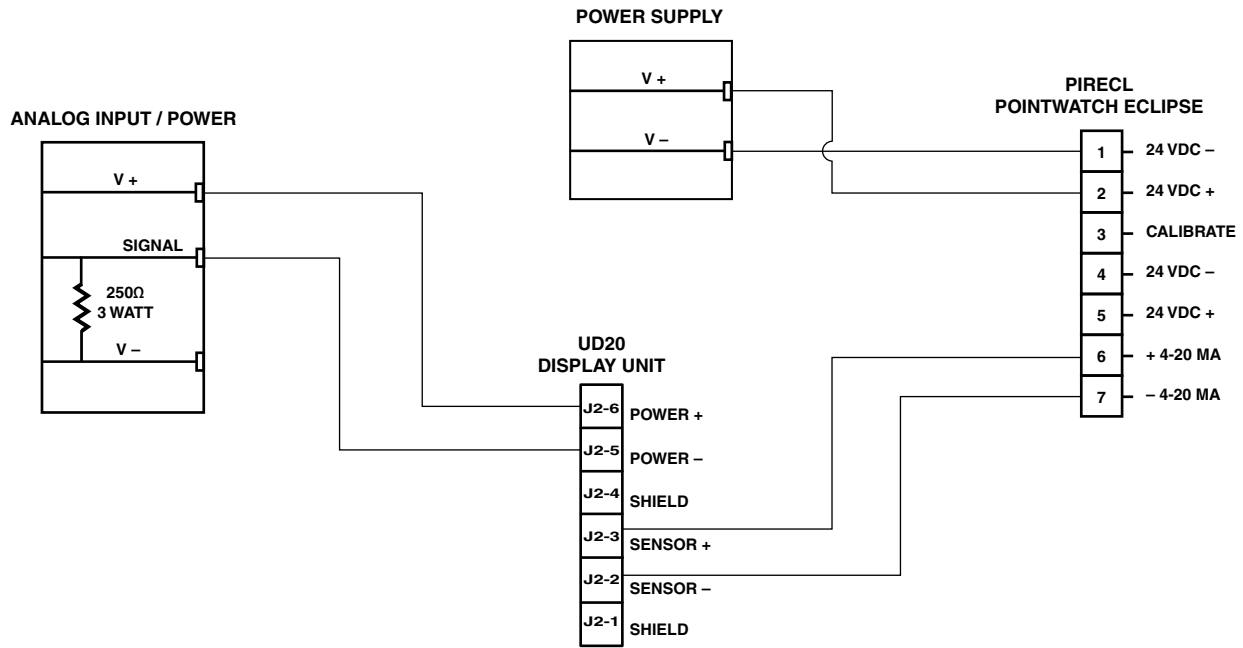

NOTE 1 JUNCTION BOXES MUST BE ELECTRICALLY CONNECTED TO EARTH GROUND.
 NOTE 2 THE TOTAL LOOP RESISTANCE = 250 OHMS MINIMUM, 440 OHMS MAXIMUM.

B2691

Figure 8—PIRECL Detector Wired to UD20 (Isolated 4-20 mA Output, Sourcing, 4-Wire)

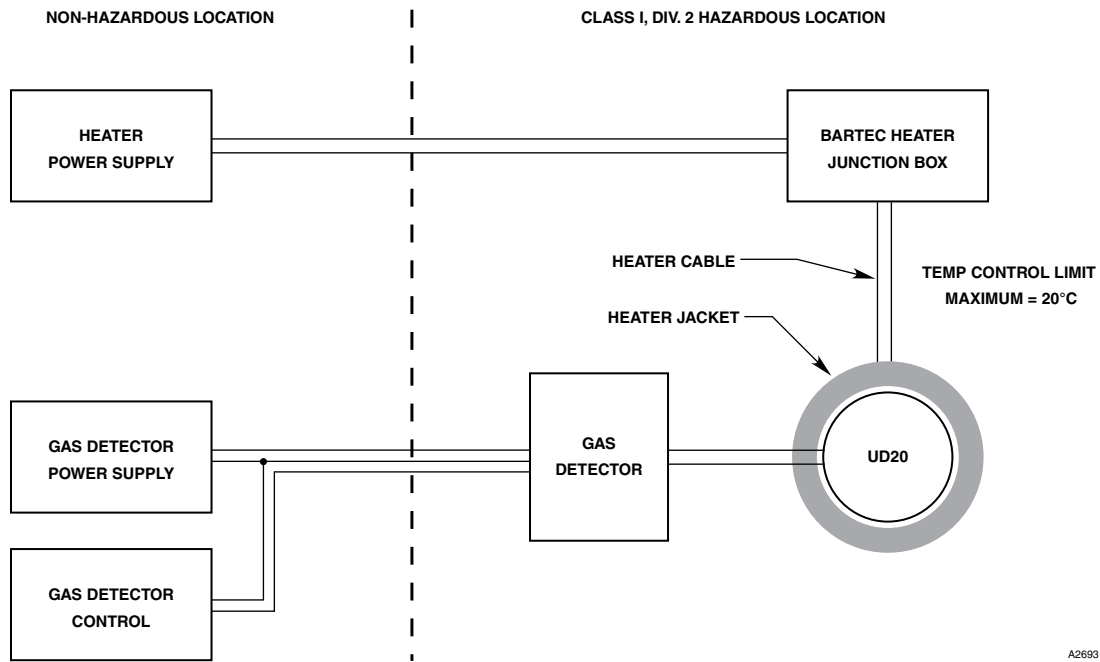

A2693

Figure 9—UD20 with Bartec Self-Regulating Heating Cable System

Table 1— GT3000 LEDs During Calibration

Device Status	Green LED	Yellow LED
Normal	Steady On	Off
Waiting for Zero	Off	Steady On
Waiting for Gas	Off	Blinking
Waiting for Span	Off	Blinking
Remove Cal Gas	Off	Off
Normal	Steady On	Off

CALIBRATION

The calibration process is automatic, with the exception of gas delivery. LEDs on the gas detector and messages on the UD20 faceplate guide the operator when to apply and remove the calibration gas. See Tables 1 and 2.

NOTE

The UD20 allows the operator to adjust the calibration gas concentration within the range of 30 to 90% full scale. The default value for all gas sensors except oxygen is 50% full scale. Oxygen sensors use a default value of 20.9%.

The calibration process can be initiated using the magnetic switch on the gas detector or using the magnetic switches on the UD20 faceplate. All sensors, including oxygen, should be in clean air (20.9% oxygen) when the calibration sequence is initiated.

Once calibration is initiated, the process proceeds automatically. The yellow LED on the gas detector and the digital display on the UD20 are used to inform the operator of the progress of the calibration procedure, and also signal when to apply and when to remove the calibration gas.

GENERAL CALIBRATION INFORMATION

All GT3000 and PIRECL Gas Detectors provide a two-point calibration — zero and span.

The calibration can be aborted after zero calibration by activating the magnetic switch on the gas detector or navigating the UD20 menu.

Table 2—PIRECL LEDs and Current Output Status During Normal Calibration Procedure

Description	Indicating LED (on-board/PIRTB)	Operator Action
Normal-ready to calibrate	steady green/off	Purge with clean air if required
Initiate Calibration	steady red/on-steady	Apply Magnet for 2 seconds min.
Zero Calibration complete	flashing red/on-flashing	Apply Calibration Gas to device
Span Calibration in progress	flashing red/on-flashing	Continue cal gas flow
Span Calibration complete	off/on-steady	Remove Calibration Gas
Output Returns to Normal	steady green/off	Calibration Completed
Normal Operation	steady green/off	None

If the calibration sequence is aborted or not completed successfully, the detector reverts back to the previous calibration values and signals a calibration fault. If a successful calibration cannot be performed, the calibration fault can be cleared by activating the magnetic switch on the gas detector for one second.

For help assessing when a fault has occurred see Tables 3 and 4.

The calibration process can fail for the following causes:

- Zero is out of range
- Span is out of range
- Time-Out.

The time and date of calibration events are logged in the GT3000's non-volatile memory along with the calibration outcome. Possible calibration scenarios include the following:

- Successful Calibration
- Aborted Calibration
- Failed Calibration

NOTE

The calibration procedure must be completed within a ten minute period. If the calibration is not completed, a calibration fault will be generated and the previous calibration data will be used.

NOTE

To ensure reliable protection, it is important to check and calibrate the detection system on a regularly scheduled basis. The frequency of these checks is determined by the requirements of the particular installation – typically 30, 60, or 90 day intervals, depending on the ambient conditions.

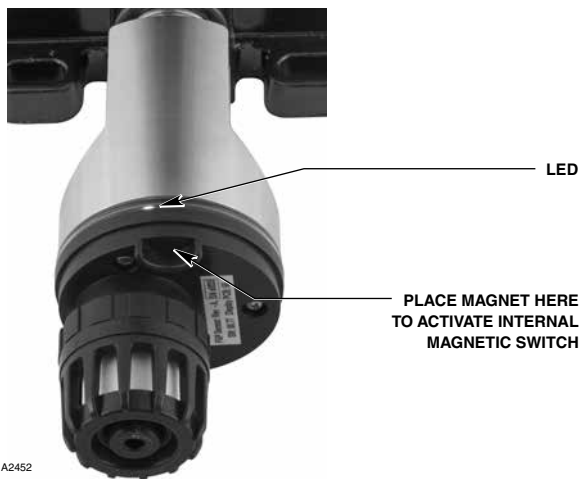

Figure 10—Location of Magnetic Switch on GT3000 Detector

Table 3— GT3000 LEDs and 4-20 mA Output During Various Status Conditions

Function	Green LED	Yellow LED	Analog 4-20 mA Signal
Warm-up	Off	Steady On	3.5
Normal Operation	Steady On	Off	4-20
Fault Condition	Off	Steady On	3.5
Calibration	See Table 1		3.8

CALIBRATION PROCEDURE

1. Clean air must be present at the sensor prior to initiating calibration. The use of bottled air is recommended.
2. Calibration can be initiated in one of two ways:
 - A. Hold the calibration magnet against the designated location on the sensor module (see Figures 10 and 11) until the green LED turns off and the yellow LED turns on steady (approximately one second).
 - B. Initiate calibration via the magnetic switches on the UD20. Select Main Menu > Device Cal > Calibration > Execute.

The UD20 indicates “Waiting for Zero.” The transmitter immediately begins taking zero readings.

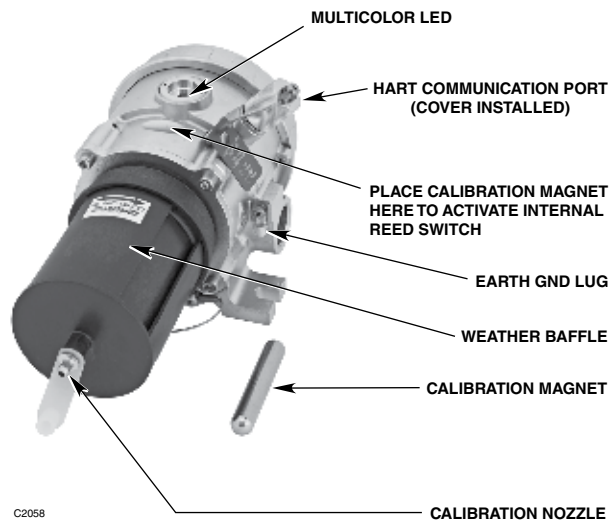

Figure 11— Location of Magnetic Switch on PointWatch Eclipse

Table 4— PIRECL LEDs and 4-20 mA Output During Various Status Conditions

Function	Green LED	Yellow LED	Analog 4-20 mA Signal
Warm-up	Off	Steady On	3.0
Normal Operation	Steady On	Off	4-20
Fault Condition	Off	Steady On	3.0
Blocked Optics	Off	Steady On	3.0
Calibration	See Table 2		3.8

- When the zero calibration is complete, the yellow LED changes from steady to blinking and the UD20 indicates "Waiting for Gas." Apply the calibration gas to the sensor. When gas is detected, the UD20 indicates "Waiting for Span."
- When the yellow LED turns off and the UD20 indicates "Remove Cal Gas", remove the calibration gas. The gas level at the sensor gradually returns to zero. The green LED turns on steady to indicate that the device has returned to normal operation, using the new calibration data.

INPUT TRIM

The input current loop of the UD20 is trimmed at the factory. However, it can also be trimmed in the field using the following automated process.

Navigate through the menu to "Input Loop Cal."

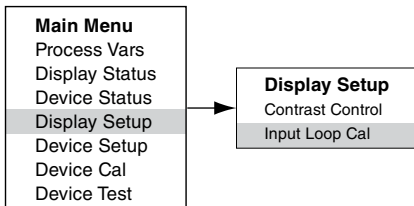

Upon entering Input Loop Cal, the UD20 commands the detector to output 4 mA, and then automatically calibrates its own input. The UD20 then commands the detector to output 20 mA, and subsequently calibrates its own input.

SPECIFICATIONS

UD20 UNIVERSAL DISPLAY UNIT

OPERATING VOLTAGE—

24 Vdc nominal, operating range is 19 to 30 Vdc. UD20 maximum loop voltage drop (Vd) 5.0 volts. Maximum loop supply 30.0 Vdc.

OPERATING POWER—

0.8 watt maximum.

OPERATING CURRENT—

A minimum of 3.5 mA.

CURRENT OUTPUT—

Linear 4-20 mA

(with HART output directly from detector).

250 ohm, 3 watt termination resistor required (included).

OPERATING TEMPERATURE—

-20°C to +70°C.

STORAGE TEMPERATURE—

-40°C to +70°C.

HUMIDITY RANGE—

5 to 95% RH (Det-Tronics verified).

SENSOR COMPATIBILITY—

The UD20 can be used with any of the Det-Tronics GT3000 line of gas detectors, or the Det-Tronics Model PIRECL hydrocarbon gas detector.

WIRING TERMINALS—

Terminals can handle wire sized from 22 to 14 AWG.

CONDUIT ENTRIES—

3/4" NPT or M25. (Five conduit entries standard.)

ENCLOSURE MATERIAL—

Epoxy coated aluminum or 316 stainless steel.

SHIPPING WEIGHT—

Aluminum: 4.15 pounds (1.88 kilograms).

Stainless steel: 10.5 pounds (4.76 kilograms).

DIMENSIONS—

See Figures 12 and 13.

ELECTRO-MAGNETIC COMPATIBILITY—

EMC Directive 2004/108/EC

EN55011 (Emissions)

EN50270 (Immunity)

WARRANTY—

12 months from date of installation or 18 months from date of shipment, whichever occurs first.

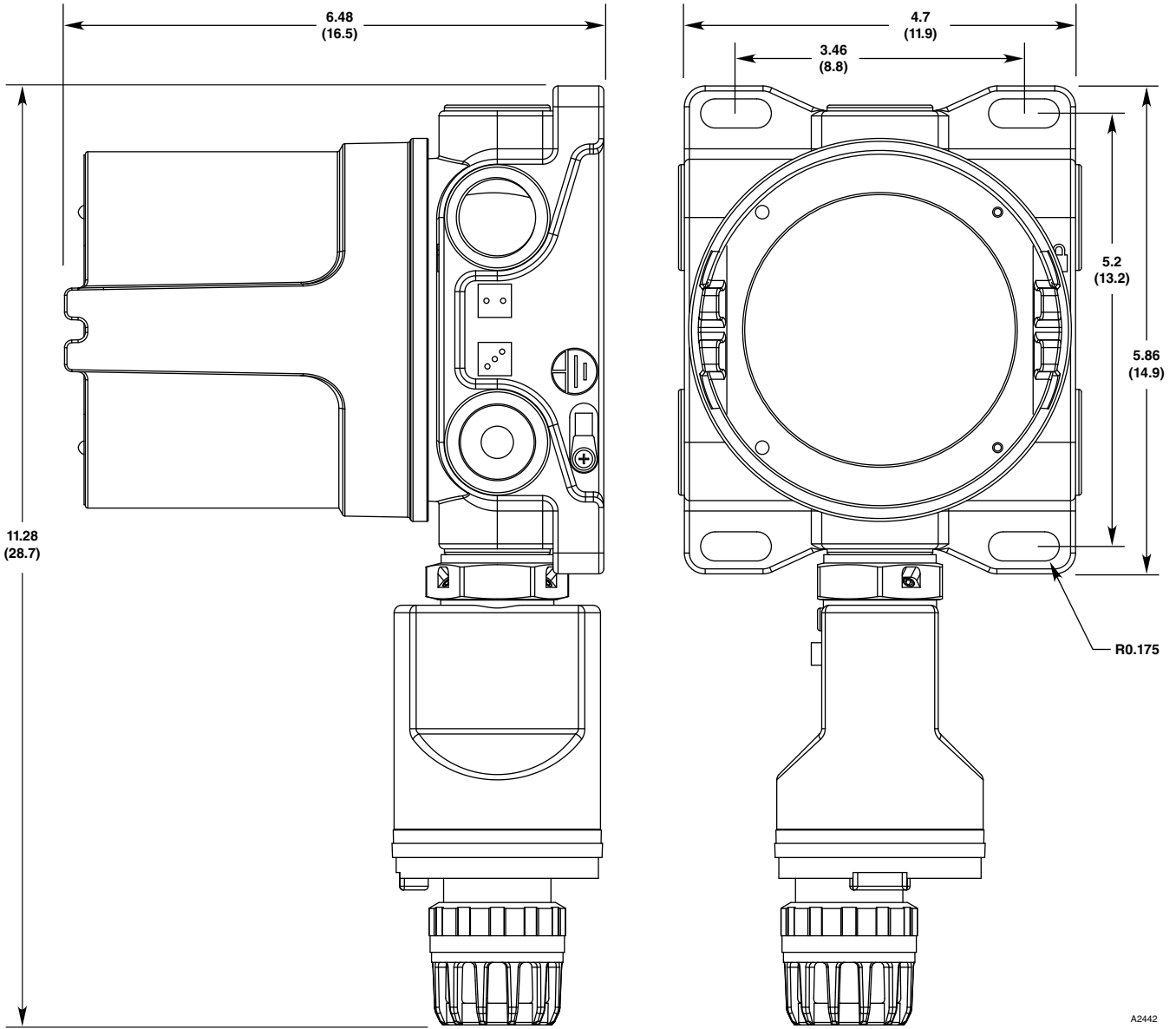

A2442

Figure 12—Dimensions of UD20 with GT3000 in Inches (Centimeters)

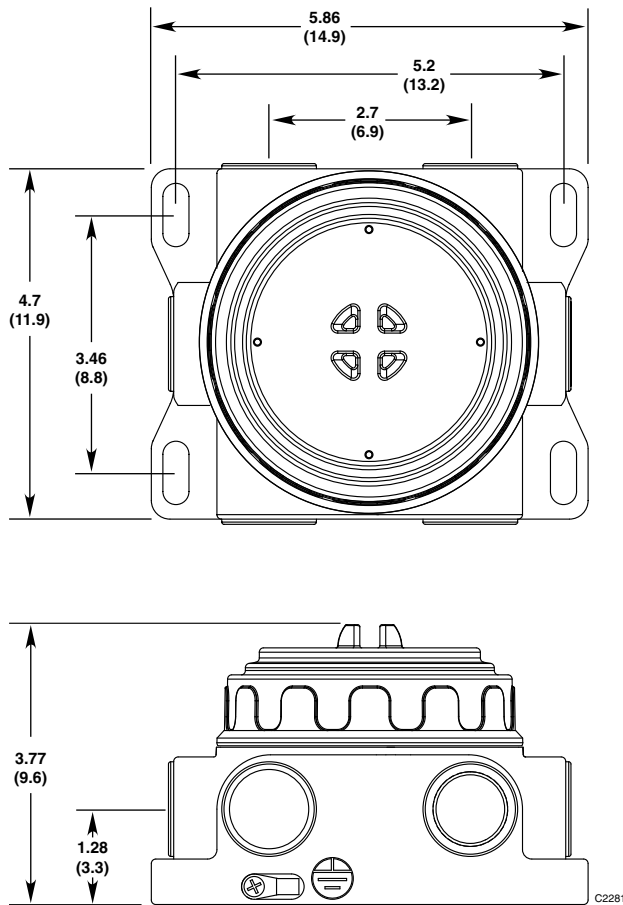

Figure 13—Dimensions of Model STB Termination Box in Inches (Centimeters)

SPECIAL CONDITIONS OF USE

1. The UD20 control unit complies with EN 60079-29-1 only when connected to a Detector head that also has been evaluated to EN 60079-29-1.
2. Flameproof joints are not user serviceable; contact Det-Tronics Service.

UD20 CERTIFICATIONS—

FM:



Class I, Div. 1, Groups B, C & D;
 Class I, Div. 2, Groups B, C & D (T4);
 Class I, Zone 1/2 AEx d IIC T6;
 Class II/III, Div. 1/2, Groups E, F & G.
 Tamb -20°C to +70°C
 NEMA/Type 4X, IP66
 Conduit seal not required.

Performance verified in accordance with:
 ANSI/ISA-92.00.01
 FM 6340
 ANSI/ISA 60079-29-1
 FM 6320

CSA:



CSA 08 2162793.
 Class I, Div. 1, Groups B, C & D;
 (Tamb = -20°C to +70°C).
 Class II/III, Div. 1/2, Groups E, F & G;
 (Tamb = -20°C to +70°C).
 Class I, Div. 2, Groups A, B, C & D (T4);
 (Tamb = -40°C to +70°C) with
 Bartec Self-Regulating Heating
 Cable System. (Install per Figure 9.)
 Type 4X, IP66.
 Conduit seal not required.

ATEX:



CE 0539 Ex II 2 G
 Ex db IIC T6
 Tamb -20°C to +70°C
 FM08ATEX0044X
 IP66
 Performance verified in accordance with:
 EN 60079-29-1.

IECEX:



Ex db IIC T6
 Tamb -20°C to +70°C
 IECEX FMG 08.0010X
 IP66
 Performance verified in accordance with:
 IEC 60079-29-1.

INMETRO



UL-BR 15.0469X
 Ex d IIC T6 Gb IP66
 T6 (Tamb -20°C to +70°C)

All cable entry devices shall be Brazil certified in the type of explosion protection, flameproof enclosure “d,” suitable for the conditions of use and correctly installed, with an ingress protection rating of IP66.

A screw or cover lock is provided for a secondary means of fastening the cover.

DEVICE REPAIR AND RETURN

Prior to returning devices, contact the nearest local Detector Electronics office so that a Return Material Identification (RMI) number can be assigned. **A written statement describing the malfunction must accompany the returned device or component to assist and expedite finding the root cause of the failure.**

Pack the unit properly. Always use sufficient packing material. Where applicable, use an antistatic bag as protection from electrostatic discharge.

NOTE

Inadequate packaging that ultimately causes damage to the returned device during shipment will result in a service charge to repair the damage incurred during shipment.

Return all equipment transportation prepaid to the factory in Minneapolis.

NOTE

It is highly recommended that a complete spare be kept on hand for field replacement to ensure continuous protection.

ORDERING INFORMATION

Sensor module, Transmitter module, and termination boxes (if used) must be ordered separately.

Refer to the UD20 Model Matrix for ordering details.

REPLACEMENT PARTS/ACCESSORIES

Part Number	Description
009700-001	Magnetic Tool
009793-002	Electronics Module
010253-001	250 ohm Terminating Resistor Kit
101197-001*	Stop Plug, 3/4" NPT, AL
101197-004*	Stop Plug, 3/4" NPT, SS
101197-005	Stop Plug, M25, AL, IP66
101197-003	Stop Plug, M25, SS, IP66
010816-001	Stop Plug, 20PK, 3/4" NPT, AL, EX D
010817-001	Stop Plug, 20PK, 3/4" NPT, SS, EX D
010818-001	Stop Plug, 20PK, M25, AL, IP66, EXDE
010819-001	Stop Plug, 20PK, M25, SS, IP66, EXDE
104190-001	Stop Plug, M25, AL, INMETRO
104190-002	Stop Plug, 3/4" NPT, AL, INMETRO
104190-003	Stop Plug, M25, SS, INMETRO
104190-004	Stop Plug, 3/4" NPT, SS, INMETRO
102804-001	Reducer, M25 to M20, AL
102804-003	Reducer, M25 to M20, SS
103922-001	475 Field Communicator
005003-001	Lubriplate grease, 1 oz.
107427-040	O-ring - Viton
104371-001	Bartec Self-Regulating Heating Cable System

*NEMA 4/IP66 rating requires addition of non-hardening thread sealant or Teflon tape.

UD20 MODEL MATRIX

MODEL	DESCRIPTION	
UD20	Universal Display Unit	
	TYPE	MATERIAL
	A	Aluminum
	S	Stainless Steel (316)
	TYPE	THREAD TYPE
	5M	5 PORT, METRIC M25
	5N	5 PORT, 3/4" NPT
	TYPE	OUTPUTS
	26	Pass-Through 4-20 mA, HART
	TYPE	APPROVAL
	W	FM/CSA/ATEX/IECEX
B	INMETRO (Brazil)	
TYPE	CLASSIFICATION (Div/Zone)	
2	Ex d (Flameproof)	

APPENDIX A

HART COMMUNICATION – UD20 WITH GT3000

MENU STRUCTURE

This section displays the menu trees for the UD20 connected to the GT3000. The menu tree shows the primary commands and options available when using menu selections.

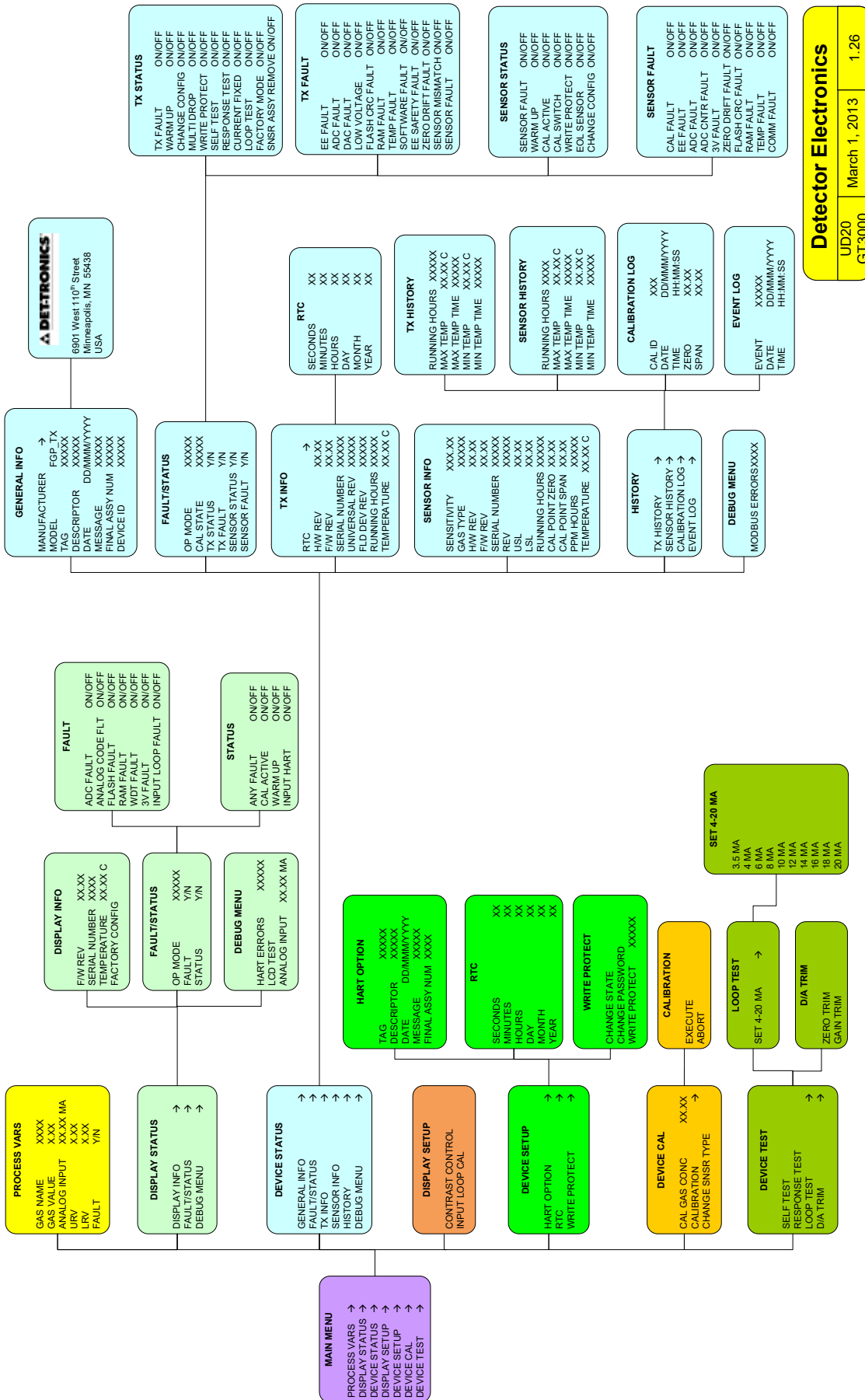

APPENDIX B

HART COMMUNICATION – UD20 WITH PIRECL

MENU STRUCTURE

This section displays the menu trees for the UD20 connected to the PIRECL. The menu tree shows the primary commands and options available when using menu selections.

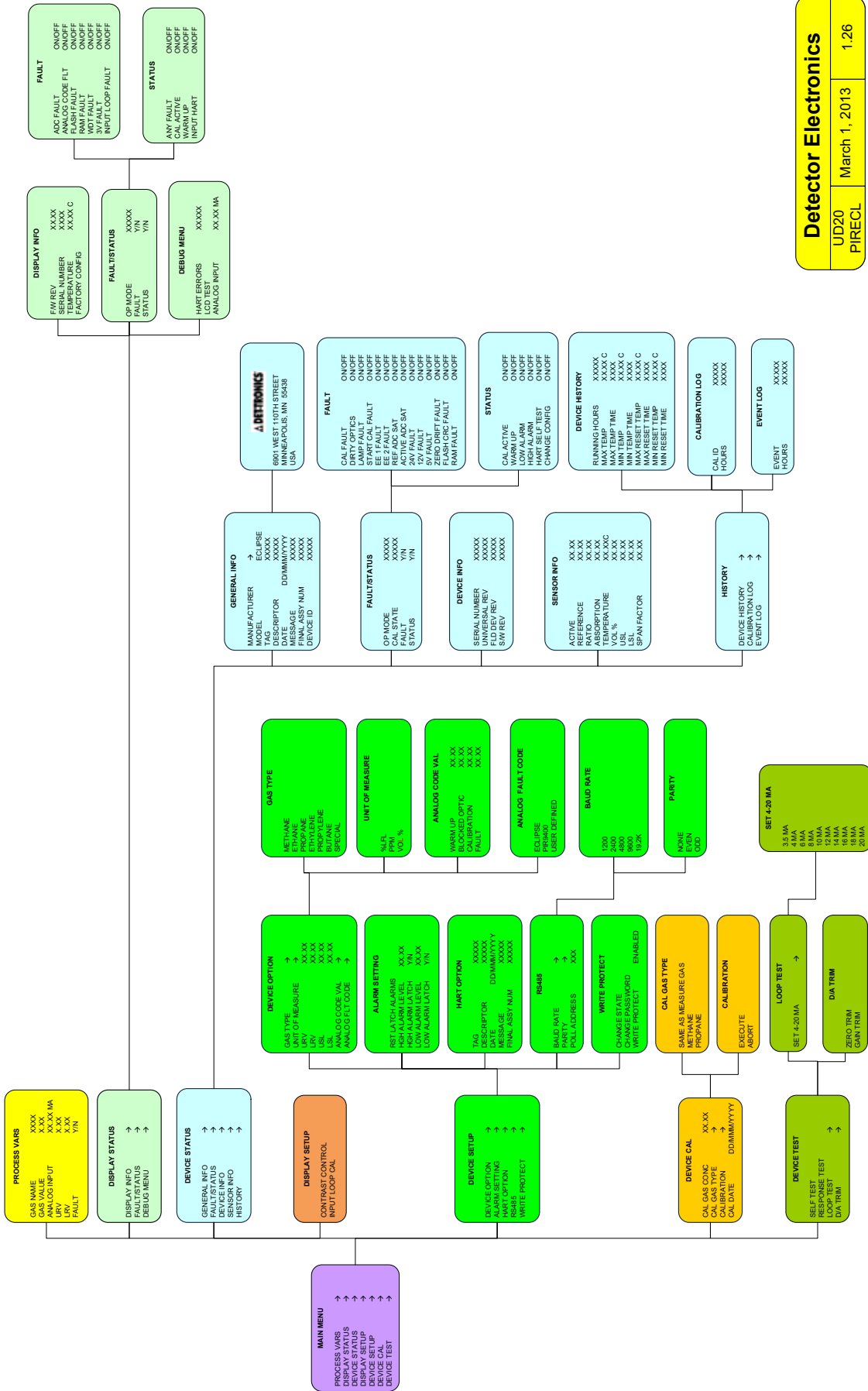



95-8620



FlexSonic® Acoustic
Leak Detector



X3301 Multispectrum
IR Flame Detector



PointWatch Eclipse® IR
Combustible Gas Detector



FlexVu® Universal Display
with GT3000 Toxic Gas Detector



Eagle Quantum
Premier®
Safety System

Corporate Office
6901 West 110th Street
Minneapolis, MN 55438 USA
www.det-tronics.com

Phone: 952.946.6491
Toll-free: 800.765.3473
Fax: 952.829.8750
det-tronics@det-tronics.com

All trademarks are the property of their respective owners.
© 2018 Detector Electronics Corporation. All rights reserved.

Det-Tronics manufacturing system is certified to ISO 9001—
the world's most recognized quality management standard.

